



Installation, Operation & Maintenance Instructions

Gas Cooled Chambers
GCC Models

This manual is for the guidance of operators of the above Carbolite products and should be read before the oven is connected to the electricity supply.

CONTENTS

Section		Page
1.0	Symbols & Warnings	1
2.0	Installation	3
3.0	Operation	4
4.0	Maintenance	6
5.0	Repairs & Replacements	7
6.0	Fault Analysis	9
7.0	Circuit Diagrams	10
8.0	Specifications	12

Manuals are supplied separately for the temperature controller (and overtemperature controller when fitted).

Please read the controller manuals before operating the oven.

SYMBOLS & WARNINGS

1.1 Switches and Lights



Supply Light: when the oven is connected to the electrical supply the light in the adjacent switch glows

1.2 Warning Symbols

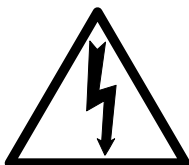

DANGER of electrical shock— read any warning printed by this symbol.



DANGER – hot surface. Read any warning printed by this symbol.
WARNING: all surfaces of an oven may be hot.



DANGER – read any warning printed by this symbol.

1.3 Safety Considerations – Liquid Gases

The GCC ovens are designed to be used with customer-supplied liquid Carbon Dioxide (CO₂), or, as an option, liquid Nitrogen (N₂). There are health hazards association with these supplies.



Hazards to health are due either to intense cold or to displacement of air by rapidly evaporating solid or liquid. CO₂ turns to solid “dry ice” on leaving the cylinder, at –68°C; N₂ leaves the dewar as a liquid at around –196°C.

Even brief contact with solid CO₂ or liquid N₂ can cause skin damage similar to heat burns. If skin comes into contact with uninsulated parts of cold equipment – for example the metal interior of the oven chamber – it may stick fast, and flesh may be torn on removal. Unprotected hands working in a cold chamber for long periods could suffer frostbite.

Breathing of extremely cold atmospheres may damage lung tissue.

Evaporated CO₂ and N₂ are non-toxic but will not support life. Spillages or leaks, or even normal use in confined or unventilated spaces, could cause asphyxiation. Cold evaporated gases are dense and tend flow to ground level; they may appear as areas of misting, but may be invisible.

To protect the hands wear loose fitting (easily removable), non-absorbent, leather gloves.

To protect the face, if there is any danger of splashing, wear goggles or a protective mask.

Should clothing become saturated with liquid or evaporated gases, walk around a well-ventilated area for 5 minutes.

General spillages: ventilate the area and keep clear of misty vapour and floor level.

On no account allow animals or children into the vicinity of the equipment.

2.0 INSTALLATION

2.1 Unpacking & Handling

Remove the shelves and runners from the packaging before attempting to move the equipment. Lift the unit by its base. The door should not be used to support the equipment when moving it. Use two people to carry the oven where possible. Remove any packing material from the inner chamber before use.

2.2 Siting & Setting Up

Place the oven on a level surface. If under/over-temperature protection is not fitted, ensure that the unit can be directly observed.

Ensure that there is at least 50mm free space behind and around the oven. There are vents in the back that must not be obstructed. Some models have protruding fan motor housings: these housings must be in an area of good ventilation.

Ensure that the oven is placed in such a way that it can be quickly switched off or disconnected from the electrical supply - see below.

Read section 1.3 and give due consideration to the siting of the equipment so that danger from escaping gases is minimised.

2.3 Electrical Connections

Connection by a qualified electrician is recommended.

All models covered by this manual are made for use on a single phase A.C. supply, which may be Live to Neutral non-reversible, Live to Neutral reversible or Live to Live. Check the oven rating label before connection. The supply voltage should agree with the voltage on the label, and the supply capacity should be sufficient for the amperage on the label.

The supply should be fused at the next size equal to or higher than the amperage on the label. A table of the most common fuse ratings is also given in section 7.3 of this manual. Where a supply cable is present there are internal supply fuses; customer fusing is preferred but not essential.

Oven with supply cable: either wire directly to an isolator or fitted with a line plug. The plug should be within reach of the operator, and should be quickly removable.

Oven without supply cable: a permanent connection to a fused and isolated supply should be made to the internal terminals after temporary removal of the back panel; this should operate on both conductors. It should be within reach of the operator.

The supply MUST incorporate an earth (ground).

CONNECTION DETAILS			<i>supply type</i>	
Supply	Terminal label	Cable colour	<i>Live-Neutral</i>	<i>Reversible or Live-Live</i>
<i>1-phase</i>	L	Brown	To live	to either power conductor
	N	Blue	To neutral	to the other power conductor
	PE	Green/Yellow	To earth (ground)	to earth (ground)

2.4 Liquid Gas Connection



There are dangers associated with liquid gases: see section 1.3.

The oven is supplied either for use with liquid CO₂ (standard) or with liquid N₂ (option). There are different internal components for these gases: only connect to the gas for which the unit was ordered. *If in doubt ask Carbolite – each oven made has an individual record card.*

The oven is supplied with a length of high pressure flexible hose. This screws into the fitting at the rear of the oven and connects direct to the liquid gas supply.

CO₂: the cylinder must be of the type fitted with a dip tube, so that the liquid phase is delivered to the chamber. Cylinders with a dip tube normally have a white stripe down the side. No pressure regulator is required.

N₂: an insulated stainless steel hose is supplied for connection to the dewar. The dewar should be of the self-pressurising type, able to supply pressure up to 2 bar. Use the lowest pressure consistent with achieving the desired temperature. A dewar size of at least 100 litres is recommended.

3.0 OPERATION

The instructions for operating the temperature controller are given in a separate manual. If the oven is fitted with a time switch, see also the supplementary manual MS03. If the oven has a variable speed fan please see section 3.6 in this manual.

3.1 Summary of Heating and Cooling System

The heating is provided by mineral insulated elements in the furnace chamber, switched off and on by a solid state relay under the control of a temperature controller/programmer.

The cooling is supplied by a stream of cold gas, switched on and off by a solenoid valve under the control of an “alarm” feature in the controller/programmer. There is also a “cool switch” by which the gas supply may be manually allowed or disallowed.

Temperature control is achieved by balance between cooling and heating effects. The cooling can be viewed as a coarse control, with the fine control achieved by heating.

Above ambient temperature (with the cool switch off) the unit performs like a conventional fan oven.

The oven is fitted with a combined Supply light and Instrument switch. The light is on whenever the oven is connected to the supply. The switch cuts off power to the controller(s) and also cuts off the gas supply.

The oven has fan-assisted circulation. The fan operates when the instrument switch is switched on.

3.2 Operating Cycle

Connect the oven to the electrical supply. The Supply light should glow.

Operate the instrument switch to activate the temperature controller; the **O** position is *off*, the **I** position *on*. The controller becomes illuminated and goes through a short test cycle.

Adjust the temperature controller – see the controller manual.

Under/overtemperature option. If the under/over-temperature controller has not yet been set as required, set the desired under- and over-temperature setpoints, and activate it according to the instructions in the appropriate manual. The over-temperature setpoint should be at about 15°C higher than the maximum working temperature on the main controller, and the under-temperature setpoint at about 15°C lower than the minimum.

If working below ambient temperature, switch on the “cool” switch; the amber light on this switch is then illuminated.

Unless a time switch is fitted and is off, the oven starts to heat up or cool down according to the controller set point or program.

To switch the oven off, first turn off the supply valve on the gas cylinder. Wait two minutes for the liquid in the pipework to evaporate, then switch off the Cool switch. Note that this procedure is desirable, but not essential for safety because there is a pressure overload device in the pipework.

Set the Instrument switch to **O**. If the oven is to be left off, isolate it from the electrical supply.

3.3 Under/Over-temperature Control (if fitted)

An under-temperature cuts off the cooling facility, and an over-temperature condition cuts off power to the heating elements. To reset the condition, first either allow the oven to warm up or to cool, or decrease/increase the under/over-temperature setting.

A light in the overtemperature controller flashes. Reset the under/overtemperature controller according to the instructions in the appropriate manual (please note that for convenience the manual only refers to the over- condition).

3.4 Vents

There is an exhaust port on the top of the oven. This should be left open when gas cooling is in operation, to ensure that the liberated gases can escape from the chamber. Some frosting around the exhaust pipe is to be expected as water vapour condenses onto it. Also, at low temperatures, there may be some visible escape of liberated gas around the door.

Other ports may be fitted to customer requirements: leave them closed when not in use.

3.5 Temperature Uniformity

Where accurate temperature control of the load is important, use the central part of the chamber and place or distribute the load to allow free air circulation. Do not place loads on the chamber floor: use the bottom shelf.

3.6 Variable Speed Fan Option

When this is ordered, a variable speed control is fitted in the fan circuit. Operation of the control is self-explanatory.

Please note that there is a minimum setting at which the fan motor starts up when the oven is switched on. Find this setting by experiment, and mark the position on the control or front panel.

It is unlikely that a control setting of less than 50% would ever be required, as there would be very little air flow inside the oven.

3.7 Explosive Vapours



These models are not suitable for drying or heat treatment applications where vapours are released that are combustible or that can form explosive mixtures with air. For such applications only use models supplied with the stoving and curing option.

3.8 Caution – Liquid Gases



Liquid carbon dioxide and liquid nitrogen can cause burns if mishandled. All operators should read the safety notes in section 1.3.

4.0 MAINTENANCE

4.1 General Maintenance

No routine maintenance is required other than the occasional replacement of consumable items.

The oven outer surface may be cleaned with a damp cloth. Do not allow water to enter the interior of the case. Do not clean with organic solvents.

Fan models: the motor is sealed for life; no lubrication is required.

Check the door seal regularly for cuts or tears. A damaged seal increases cooling gas consumption.

4.2 Calibration

After prolonged use the controller and/or thermocouple could require recalibration. This would be important for processes that require accurate temperature readings. A quick check using an independent thermocouple and temperature indicator should be made from time to time to determine whether full calibration is required.

For a quick check of the temperature shown by the control thermocouple and oven controller, a portable temperature indicator and probe thermocouple may be used. Carbolite can supply these items.

Depending on the controller, the controller manual may contain calibration instructions.

4.3 After Sales Service

Carbolite's service division (Thermal Engineering Services) has a team of Service Engineers capable of repair, calibration and preventive maintenance of furnace and oven products at our customers' premises throughout the world. We also sell spares by mail order. A telephone call or fax often enables a fault to be diagnosed and the necessary spare part despatched.

Each oven has its own record card at Carbolite. In all correspondence please quote the serial number, model type and voltage given on the rating label of the oven. The serial number and model type are also given on the front of this booklet when supplied with an oven.

To contact Thermal Engineering Services or Carbolite see the back page of this manual.

4.4 Recommended Spares Kits

Carbolite can supply individual spares, or a kit of the items most likely to be required. Ordering a kit in advance can save time in the event of a breakdown. Each kit comprises a thermocouple, a solid state relay, an instrument switch, an element or set of elements, and a door seal; for fan models the kit includes a fan and motor assembly. Individual spares are also available.

When ordering spares please quote the model details as requested above.

4.5 Power Adjustment

The control system incorporates electronic power limiting, but in these models the power limit is set to 100%. The power limit parameter OP.Hi may be accessible to the operator, but should not generally be altered.

5.0 REPAIRS & REPLACEMENTS

5.1 Safety Warning – Disconnection from Electric Supply

Always ensure that the oven is disconnected from the electric supply before repair work is carried out.



5.2 Safety Warning – Disconnection from Gas Supply

Always ensure that the oven is disconnected from the liquid gas supply before repair work is carried out



5.3 Safety Warning - Refractory Fibrous Insulation

This oven contains refractory fibres in its thermal insulation. These materials may be in the form of fibre blanket or felt, vacuum formed board or shapes, mineral wool slab or loose fill fibre.



Normal use of the oven does not result in any significant level of airborne dust from these materials, but much higher levels may be encountered during maintenance or repair.

Whilst there is no evidence of any long term health hazards, we strongly recommend that safety precautions are taken whenever the materials are handled.

Exposure to dust from fibre that has been used at high temperatures may cause respiratory disease.

When handling fibre always use an approved mask, eye protection, gloves and long sleeved clothing.

Avoid breaking up waste material. Dispose of waste fibre in sealed containers.

After handling rinse exposed skin with water before washing gently with soap (not detergent). Wash work clothing separately.

Before commencing any major repairs we recommend reference to the European Ceramic Fibre Industry Association Bulletin No. 11 and the UK Health and Safety Executive Guidance Note EH46.

We can provide further information on request. Alternatively our service division can quote for any repairs to be carried out at your premises or ours.

5.4 Panel Removal



Disconnect the oven from the electrical supply.

Control panel. Open the door and remove two screws located in recesses on the left side of the control panel (these screws are covered with plastic caps). Lift the panel, pull forward the bottom of the panel, and lower the panel to disengage it from the top of the body. Note that the panel remains connected by wiring. Do not disconnect any wiring without first making a careful note of all the connections.

Internal Element Cover. Open the door. Remove any screws holding the panel.

5.5 Temperature Controller Replacement

2416, 2408 etc. Ease apart the two lugs at the side; grip the instrument and withdraw it from its sleeve; push in the replacement.

5.6 Solid-state Relay Replacement

Remove the control panel as given above. Make a note how the wires are connected to the solid state relay, and disconnect them.

Remove the solid state relay from the aluminium plate.

Replace and reconnect the solid state relay ensuring that the heat-conducting thermal pad is sandwiched between the relay and the base panel or aluminium plate. Alternatively a thin layer of white, heat-conducting silicon paste may be applied between the new relay and the plate.

Older models: the old SSR may have a separate disc-shaped "MOV" connected between the high voltage terminals. This is not required, and should be discarded.

Replace the removed panel.

5.7 Thermocouple Replacement

Remove the control panel and the internal cover as given above.

Make a note of the thermocouple connections, and how the thermocouple is placed and fixed. Colour codings are:

<i>negative</i>	<i>positive (type K)</i>
white	green

Disconnect the thermocouple from its controller terminals or terminal block.

Re-assemble with the new thermocouple observing the colour coding.

5.8 Element Replacement

Remove the control panel and the internal cover as given above. The element terminals are low down in the side compartment.

Disconnect the wires from the element terminals. Remove any starlock washers - these may need to be cut with wire cutters. Remove any clips holding the element inside the chamber, and withdraw the element.

Reverse the procedure with the new element.

Run the oven at a low temperature and check that it is controlling properly, to find out whether the element failure was caused by a fault in the control circuit.

5.9 Fuse Replacement

Remove the back panel near the supply cable entry.

Depending on the model, supply fuses and control circuit fuses may be mounted in their own holders, or may be on a circuit board that contains an EMC filter. The fuses are marked with their ratings.

Take care not to disconnect the wires leading from the EMC filter without first recording their positions: they must be reconnected to the correct terminals.

6.0 FAULT ANALYSIS

A. Oven Does Not Heat Up

- | | | |
|--|--|--|
| 1. The SUPPLY light is OFF | → No power from the supply | → Check the fuses in the supply line |
| 2. The SUPPLY light is ON | → The controller shows a very high temperature or a code such as S.br | → The thermocouple has broken or has a wiring fault |
| | → The controller shows a low temperature | → The SSR could be failing to switch on due to internal failure, faulty logic wiring from the controller, or faulty controller |
| | → There are no lights glowing on the controller | → The controller may be faulty or not receiving a supply due to a faulty switch or a wiring fault |

B. Oven Overheats

- | | | |
|---|---|---|
| 1. Oven only heats up when the instrument switch is ON | → The controller shows a very high temperature | → The controller is faulty |
| | → The controller shows a low temperature | → The thermocouple may have been shorted out or may have been moved out of the oven |
| | | → The thermocouple may be mounted the wrong way round |
| 2. Oven heats up when the instrument switch is OFF | → The SSR has failed "ON" | → The controller may be faulty |
| | | → Check for an accidental wiring fault that could have overloaded the SSR |

7.0 **CIRCUIT DIAGRAMS & FUSES**

7.1 **Single Phase – no under/over-temperature**

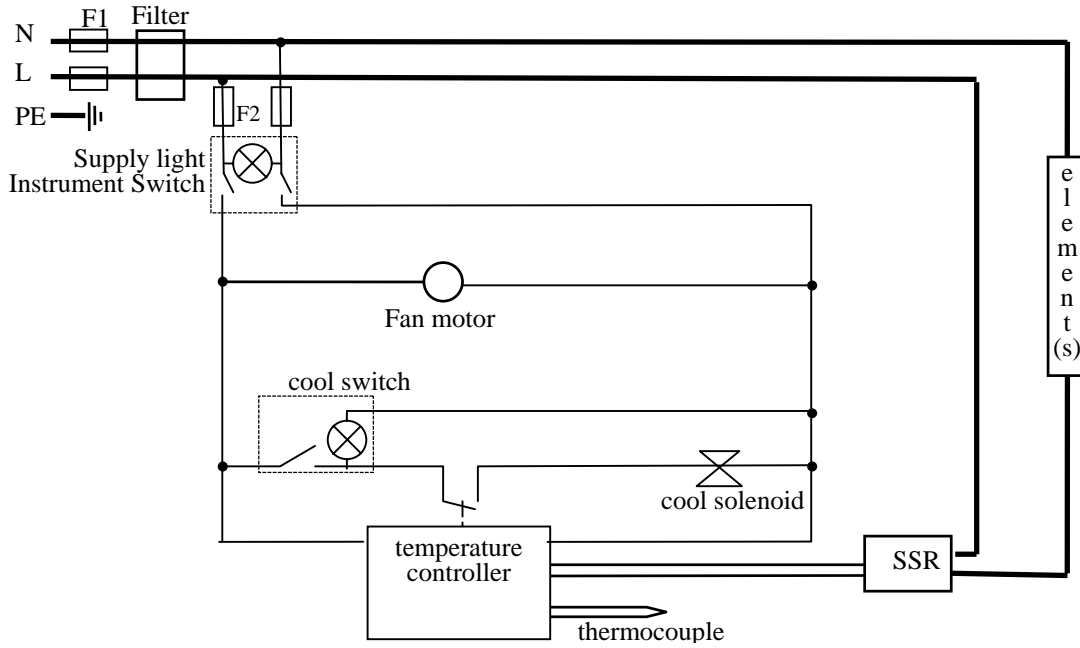

7.2 **Single Phase – with under/over-temperature**

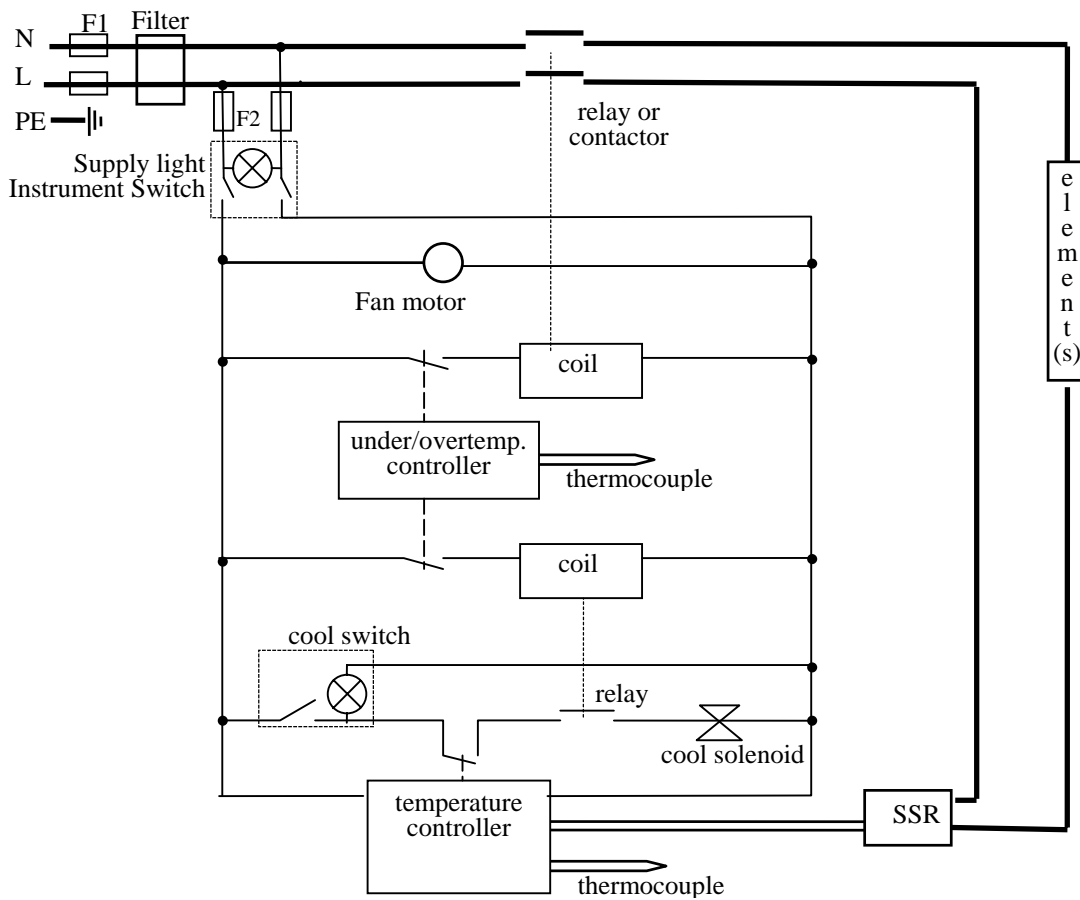

7.3 Fuses

F1-F2: Refer to the circuit diagrams.

<i>F1</i>	Internal supply fuses	Fitted if supply cable fitted. Fitted on board to some types of EMC filter.	on-board and up to 16 Amps: 32mm x 6mm type F other: GEC Safeclip
<i>F2</i>	Auxiliary circuit fuses	Fitted on board to some types of EMC filter. May be omitted up to 25Amp/phase supply rating.	2 Amps glass type F On board: 20mm x 5mm Other: 32mm x 6mm
	Customer fuses	Required if no supply cable fitted. Recommended if cable fitted.	See rating label for amperage; see table below for fuse rating.

Model	phases	Volts	Supply Fuse	Volts	Supply Fuse	Control Fuse
GCC/30	1-phase	220-240	7A	110-120	15A	2A
GCC/60	1-phase	220-240	10A	110-120	20A	2A
GCC/120	1-phase	220-240	12.5A	110-120	25	2A

208V models may have a higher fuse rating; check the rating label.

8.0 SPECIFICATIONS

Carbolite reserves the right to change specifications without notice.

8.1 Models Covered by this Manual

MODEL	Temp. range <i>see notes 1 & 2</i> (°C)	Max. Power (kW)	Chamber Size (mm)			Approx. Capacity (l)	Net Weight (kg)
			H	W	D		
<i>Gas Cooled Chambers</i>							
GCC/30	-60 to 200	1.35	310	300	330	30	77
GCC/60	-60 to 200	2.0	410	400	380	60	100
GCC/120	-60 to 200	3.0	660	500	380	120	131

note 1: with the liquid nitrogen coolant option the minimum temperature is -150°C

note 2: a high-power option is available which increases the maximum temperature to 300°C

8.2 Environment

The ovens contain electrical parts and should be stored and used in indoor conditions as follows:

temperature: $5^{\circ}\text{C} - 40^{\circ}\text{C}$ - (*note: incubators other than cooled incubators cannot maintain a low temperature unless the ambient temperature is also low*)

relative humidity: maximum 80% up to 31°C decreasing linearly to 50% at 40°C

The products covered in this manual are only a small part of the wide range of ovens, chamber furnaces and tube furnaces manufactured by Carbolite for laboratory and industrial use. For further details of our standard or custom built products please contact us at the address below, or ask your nearest stockist.

For preventive maintenance, repair and calibration of all Furnace and Oven products, please contact:

Thermal Engineering Services

Telephone: UK: 0845 3308035 Int: +44 1433 623335

Fax: UK: 0845 3308036 Int: +44 1433 623336

Email: thermalservice@dial.pipex.com



Carbolite, Parsons Lane, Hope, Hope Valley, S33 6RB, England.

Telephone: (01433) 620011

Int: +44 1433 620011

Facsimile: (01433) 621198

Int: +44 1433 621198

E-mail: enquiry@carbolite.co.uk