



Installation, Operation & Maintenance Instructions

1100°C Rotary Reactors
HTR 11/75 & HTR 11/150

This manual is for the guidance of operators of the above Carbolite products and should be read before the furnace is connected to the electricity supply.

CONTENTS

Section		page
1.0	Symbols & Warnings	2
2.0	Installation	3
3.0	Operation	5
4.0	Maintenance	7
5.0	Repairs & Replacements	8
6.0	Fault Analysis	10
7.0	Circuit Diagrams	11
8.0	Fuses & Power Settings	14
9.0	Specifications	16

Manuals are supplied separately for the furnace controller (and overtemperature controller when fitted).

Please read the controller manuals before operating the furnace.



1.0 SYMBOLS & WARNINGS

1.1 Switches and Lights



Supply Light: when the furnace is connected to the electrical supply the light in the adjacent switch glows

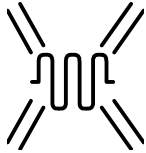

Heat Light: the adjacent light glows or flashes to indicate that power is being supplied to the elements

1.2 Warning Symbols

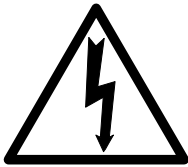

DANGER of electrical shock– read any warning printed by this symbol.



DANGER – hot surface. Read any warning printed by this symbol.
WARNING: all surfaces of a furnace may be hot.



DANGER – read any warning printed by this symbol.

2.0 INSTALLATION

2.1 Unpacking & Handling

When unpacking or moving the furnace lift it by both ends of its base. Never lift it by any protruding parts or by the lid. Preferably, use two people to carry the furnace.

Remove any packing material from around or inside the furnace before use.

2.2 Siting

Place the furnace in a well ventilated room, away from other sources of heat, and on a surface which is resistant to accidental spillage of hot materials. Do not mount the furnace on an inflammable surface.

Ensure that there is free space around the furnace. Do not obstruct any of the vents in the control section: they are needed to keep the controls cool.

Ensure that the furnace is placed in such a way that it can be quickly switched off or disconnected from the electrical supply - see below.

2.3 Electrical Connections

Connection by a qualified electrician is recommended

The furnace is made for single phase A.C. supply, which may be Live to Neutral non-reversible, Live to Neutral reversible or Live to Live.

Check the furnace rating label before connection. The supply voltage should agree with the voltage on the label, and the supply capacity should be sufficient for the amperage on the label.

The supply should be fused at the next size equal to or higher than the amperage on the label. A table of the most common fuse ratings is also given in section 8.1 of this manual. Where a supply cable is present there are internal supply fuses; customer fusing is preferred but not essential.

Furnace with supply cable: either wire directly to an isolator or fit with a line plug.

Furnace without supply cable: a permanent connection to a fused and isolated supply should be made to the internal terminals after temporary removal of the furnace back panel.

Connection by line plug: the plug should be within reach of the operator, and should be quickly removable.

Connection to isolating switch: this should operate on both conductors (single phase) or on all live conductors (three phase), and should be within reach of the operator.

The supply MUST incorporate an earth (ground).

CONNECTION DETAILS			<i>supply type</i>	
Supply	Terminal label	Cable colour	<i>Live-Neutral</i>	<i>Reversible or Live-Live</i>
<i>I-phase</i>	L	Brown	To live	to either power conductor
	N	Blue	To neutral	to the other power conductor
	PE	Green/Yellow	To earth (ground)	to earth (ground)

2.4 Gas Supply

The furnace is supplied with a Nitrogen inlet and flowmeter as standard. The gas supply must be provided with an on/off valve and pressure regulator to a maximum of 4 psi. Connect the gas supply to the inlet on the left-hand side. The exhaust box on the right-hand side may be connected to a outlet pipe provided this does not restrict the gas flow. The exhaust incorporates a safety pressure relief valve set to relieve pressure above 1 psi in case the exhaust becomes blocked.

Do not use toxic gases without taking appropriate precautions. The furnace is not suitable for use with combustible gases.

2.5 Installing the Vessel

Silica vessel: see section 3.5. Handle the vessel with care.

The drive coupling assembly is fitted to the vessel as indicated in fig. 1, using the special spanner provided. Slide the components into place, support part 2 firmly with the hand, and tighten part 1 with the spanner. Do not overtighten. The end of the vessel with this assembly fitted becomes the left-hand end.

Lightly lubricate the drive coupling assembly and the furnace drive wheels, using 300°C grease. Place the vessel onto the furnace by pushing it into the exhaust box on the right-hand side, and lowering it onto the right-hand support wheels and the left-hand drive wheels.

Connect the left-hand end coupling according to fig. 2, using hand pressure only.

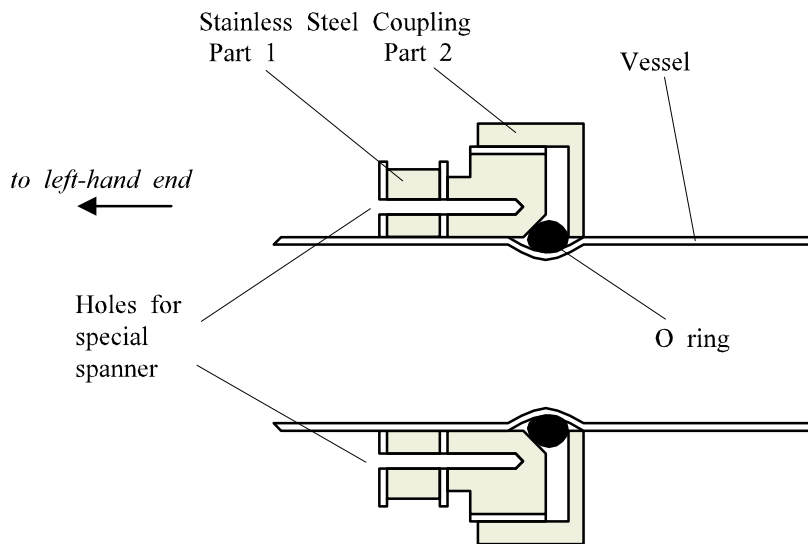

Fig. 1- Drive coupling

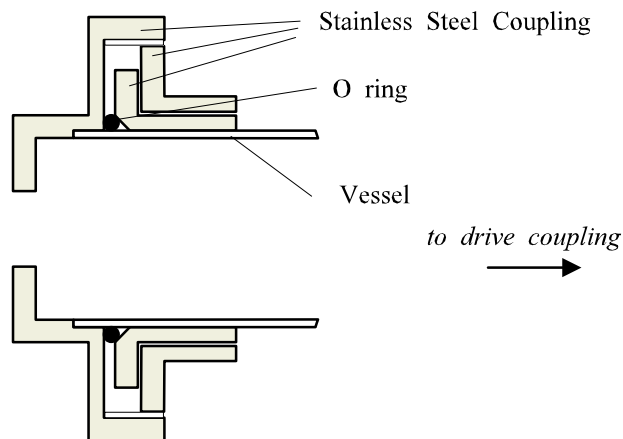

Fig. 2- End coupling

3.0 **OPERATION**

The instructions for operating the temperature controller are given in a separate manual.

If the furnace is fitted with a time switch, see also the supplementary manual MS03.

If cascade control is fitted, see the supplementary manual MS07.

3.1 **Operating Cycle**

The furnace is fitted with a combined Supply light and Instrument switch. The light is on whenever the furnace is connected to the supply. The switch cuts off power to the controller(s), to the heating elements (via a contactor), and to the vessel drive motor.

Connect the furnace to the electrical supply. The Supply light should glow.

Operate the instrument switch to activate the temperature controller; the **O** position is *off*, the **I** position *on*. The controller becomes illuminated and goes through a short test cycle. Depending on the lid, the motor setting, and the overtemperature controller (if fitted), the vessel may start to rotate.

Set the temperature controller to the desired setpoint or program – see the controller manual.

Overtemperature option only. If the overtemperature controller has not yet been set as required, set it and activate it according to the instructions in the appropriate manual.

The furnace starts to heat up. The Heat light glows steadily at first and then flashes as the furnace approaches the desired temperature or a program setpoint.

Overtemperature option only. If the overtemperature trip operates then an indicator in the overtemperature controller flashes, and the heating elements are isolated. Find and correct the cause before resetting the overtemperature controller according to the instructions supplied.

To switch the furnace off, use the Instrument switch. If the furnace is to be left off, isolate it from the electrical supply.

3.2 **Vessel & Gas Supply**

Only fill the vessel to a level below the central tube extensions, so that powder cannot work along the tube during operation.

Do not exceed the following maximum weights of load (applicable to silica glass vessels):

HTR 11/75 - 120 gm

HTR 11/150 - 950 gm

The vessel oscillation is controlled by a unit on the front panel, which has an on/off switch and a rotary dial. The dial sets speeds between 1 and 8 cycles per minute. The vessel rotates in alternate directions through an angle of 315°.

Set the flowmeter to the desired rate of gas flow.

3.3 **General Operating Notes**

Heating element life is shortened by use at temperatures close to maximum. Do not leave the furnace at high temperature when not required. The maximum temperature is shown on the furnace rating label and on the back page of this manual.

Ensure that the vessel is rotating whenever the furnace is at a high temperature, to prevent sagging.

Do not operate the furnace with toxic gases unless suitable exhaust disposal precautions are in force.

3.4 Operator Safety

The ceramic materials used in furnace manufacture become electrically conductive to some extent at elevated temperatures. Do not insert conductive tools or items in the chamber without isolating the elements. If a metal vessel is used, it should be guarded against being touched when the furnace is on.

The elements are isolated when lid is open or the instrument switch is off. For full safety, disconnect the furnace from the electrical supply.

Avoid burns. Use appropriate handling equipment, face masks, and heat resistant gloves. Before you remove a hot vessel from the furnace make sure you have a safe place to put it down. Take care: the vessel may be hot but look cold.



CAUTION: the furnace is designed for operators who understand their process. DO NOT use the equipment with dangerous gases or materials without proper safety precautions. This is the customer's responsibility: Carbolite can only advise on precautions for specific processes if asked.

3.5 Care of the Vessel (Silica)

The fused silica ("quartz") vessel is fragile and expensive: at all times take care in handling it. Always make sure that there is somewhere safe to put it down before moving it.

Fused silica has a high resistance to thermal shock. Nevertheless, avoid sudden temperature changes. For example: do not allow cold water to splash onto a hot vessel.

3.6 Devitrification and Chemical Attack (Silica)

Fused silica is liable to devitrify at high temperature. This is a recrystallisation process which is greatly affected by surface conditions and therefore by contaminants in the furnace atmosphere. At 1000°C only a highly contaminated atmosphere has a noticeable effect, but at 1100°C the rate of devitrification may become significant.

A devitrified vessel eventually fails. Failure is likely to be by cracking after cooling below 300°C.

Impurities such as alkali or alkaline earth ions, which occur in dust and perspiration, should be avoided. It is advisable to handle the vessel with clean gloves or a dry cloth, and to touch the central (hot) part as little as possible.

The silica vessel should be cleaned with pure alcohol, and wiped dry with a clean cloth.

The specific substances used by the customer's process may, of course, be prime causes of devitrification, as they may attack the vessel inner surface chemically and by abrasion. Carbolite can advise, or seek external advice, on specific materials, if requested.

The following lists some elements and compounds known to cause devitrification. The list is not exhaustive.

Severe below 1000°C	Na Fe Co Sn LiCl SnCl ₃
Severe above 1000°C	Mg Ba Mn Cu Sb MgO BaCO ₃ NaCl KCl CsCl BaCl ₂
Less severe	Al As Sn(OH) ₂ Ba(OH) ₂ CaCO ₃ CaCl ₂
Not known to cause devitrification up to 1100°C	Ca B Ti Zr V Nb Ta Cr Mo W Ni Ag Zn Cd Hg C Si Pb S Se Ir H ₂ O CaO Al ₂ O ₃ SiO ₂ P ₂ O ₅ MoO ₃ WO ₃ ThO ₂ RbCl NaBr Kbr NaI KI MgCl ₂ AlCl ₃

Some substances chemically attack silica. In particular, hydrofluoric acid attacks it at all temperatures, and phosphoric acid above 150°C. Concentrated alkaline solutions may attack at high temperatures, while carbon and some metals may cause reduction.

4.0 MAINTENANCE

4.1 General Maintenance

No routine maintenance is required. The outer surfaces may be cleaned with a damp cloth. Do not allow water to enter the interior of the case, tube or control box. Do not clean with organic solvents.

Silica vessels should be kept clean - see section 3.5.

4.2 Calibration

After prolonged use the controller and/or thermocouple could require recalibration. This would be important for processes which require accurate temperature readings or which use the furnace close to its maximum temperature. A quick check using an independent thermocouple and temperature indicator should be made from time to time to determine whether full calibration is required. Carbolite can supply these items.

Depending on the controller, the controller manual may contain calibration instructions.

4.3 After Sales Service

Carbolite's service division (Thermal Engineering Services) has a team of Service Engineers capable of repair, calibration and preventive maintenance of furnace and oven products at our customers' premises throughout the world. We also sell spares by mail order. A telephone call or fax often enables a fault to be diagnosed and the necessary spare part despatched.

Each furnace has its own record card at Carbolite. In all correspondence please quote the serial number, model type and voltage given on the rating label of the furnace. The serial number and model type are also given on the front of this booklet when supplied with a furnace.

To contact Thermal Engineering Services or Carbolite see the back page of this manual.

4.4 Recommended Spares Kits

Carbolite can supply individual spares, or a kit of the items most likely to be required. Ordering a kit in advance can save time in the event of a breakdown. Each kit comprises one thermocouple, one sheath, one solid state relay, and one heating element.

When ordering spares please quote the model details as requested above.

4.5 Power Adjustment

The furnace control system incorporates electronic power limiting. Depending on the model this has a maximum setting related to the supply voltage. The power limit parameter OPH may be inaccessible to the operator.

Occasionally the power limit is set to zero to permit demonstration of the controls without the heating elements taking power. In this case the power limit is accessible to the operator and may safely be reset to its standard value. See section 9.0 for details of power limit settings.

5.0 REPAIRS & REPLACEMENTS

5.1 Safety Warning – Disconnection from Supply

Always ensure that the furnace is disconnected from the supply before repair work is carried out.

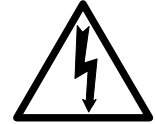

5.2 Safety Warning - Refractory Fibrous Insulation

This furnace contains refractory fibres in its thermal insulation. These materials may be in the form of fibre blanket or felt, vacuum formed board or shapes, mineral wool slab or loose fill fibre.



Normal use of the furnace does not result in any significant level of airborne dust from these materials, but much higher levels may be encountered during maintenance or repair.

Whilst there is no evidence of any long term health hazards, we strongly recommend that safety precautions are taken whenever the materials are handled.

Exposure to dust from fibre which has been used at high temperatures may cause respiratory disease.

When handling fibre always use an approved mask, eye protection, gloves and long sleeved clothing.

Avoid breaking up waste material. Dispose of waste fibre in sealed containers.

After handling rinse exposed skin with water before washing gently with soap (not detergent). Wash work clothing separately.

Before commencing any major repairs we recommend reference to the European Ceramic Fibre Industry Association Bulletin No. 11 and the UK Health and Safety Executive Guidance Note EH46.

We can provide further information on request. Alternatively our service division can quote for any repairs to be carried out at your premises or ours.

5.3 Temperature Controller Replacement

201. This controller is fitted to the back of the control panel; in many models this can be separated from the base by removal of two screws.



Before handling the controller: **wear an anti-static wrist strap** or otherwise avoid any possibility of damage to the unit by static electricity.

Refer to the detailed instructions supplied with the replacement controller.

2132, 2416, 2408 etc. Ease apart the two lugs at the side; grip the instrument and withdraw it from its sleeve; push in the replacement.

5.4 Solid-state Relay Replacement

Disconnect the furnace from the supply and remove the back panel from the base.

Make a note of how the wires are connected to the solid state relay, and disconnect them.

Remove the solid state relay from the base panel or aluminium plate.

Replace and reconnect the solid state relay ensuring that the heat-conducting thermal pad is sandwiched between the relay and the base panel or aluminium plate. Alternatively a thin layer of white, heat-conducting silicon paste may be applied between the new relay and the plate.

The new solid state relay contains a built-in MOV which protects it from short periods of excess voltage. If the old relay had a separate disc-shaped "MOV" connected between the high voltage terminals of the old relay, discard the old MOV.

Replace the removed panel.

5.5 Thermocouple Replacement

Disconnect the furnace from the supply, and remove the back panel. The thermocouple and its sheath are on the exhaust (right-hand) side.

Make a note of the thermocouple connections. The negative leg of the thermocouple is marked blue. Compensating cable colour codings are:

<i>negative</i>	<i>positive (type K)</i>
white	green

Disconnect the thermocouple from its terminal block.

Withdraw the thermocouple from its sheath and remove any broken bits of thermocouple.

Insert the new thermocouple into position, restoring any removed porcelain spacers, and ensuring correct polarity.

Re-assemble the furnace.

5.6 Element Replacement



See section 5.2 - wearing a face mask is recommended.

The element is supplied complete with the surrounding stainless steel half-cylindrical inner chamber.

Disconnect the furnace from the electrical supply, and remove the back panel. Work with the furnace lid open, with no vessel in place.

Make a careful note of the colours and positions of all the electrical connections to the inner cylindrical chamber and thermocouple.

Disconnect the thermocouple and element connections from their terminal blocks.

Remove the thermocouple. It may also be necessary to remove the thermocouple sheath: loosen the retaining screw and withdraw the sheath.

Supporting the weight of the inner chamber, loosen 4 screws holding brackets to the top plate; loosen and remove 4 screws holding the chamber to the brackets.

Lift out the inner chamber.

Fit the new chamber by reversing the process. Take care to make all connections to the correct terminals. Do not overtighten the connectors in porcelain terminal blocks.

Let the furnace heat up at its maximum rate to 900°C without interruption, and then soak for 1 hour. Fumes may be emitted: this should be done in conditions of good ventilation.

Check that the furnace is controlling properly to rule out the possibility that the element failed because of a fault in the control system.

If you have any problems with this procedure, please contact our service division.

6.0 FAULT ANALYSIS

A. Furnace Does Not Heat Up

- | | | | |
|----|-------------------------------------|--|--|
| 1. | The HEAT light is ON | → The heating element has failed | → Check also that the SSR is working correctly |
| 2. | The HEAT light is OFF | The controller shows a very high temperature or a code such as S.br | → The thermocouple has broken or has a wiring fault |
| | | The controller shows a low temperature | → The door switch(es) (if fitted) may be faulty or need adjustment |
| | | | → The contactor (if fitted) may be faulty |
| | | | → The SSR could be failing to switch on due to internal failure, faulty logic wiring from the controller, or faulty controller |
| | | There are no lights glowing on the controller | → The SUPPLY light is ON → The controller may be faulty or not receiving a supply due to a faulty switch or a wiring fault |
| | | | → The SUPPLY light is OFF → Check the supply fuses and any fuses in the furnace control compartment |

B. Furnace Overheats

- | | | | |
|----|---|---|--|
| 1. | The HEAT light goes OFF with the instrument switch | → The controller shows a very high temperature | → The controller is faulty |
| | | → The controller shows a low temperature | → The thermocouple may have been shorted out or may have been moved out of the heating chamber |
| | | | → The thermocouple may be mounted the wrong way round |
| | | | → The controller may be faulty |
| 2. | The HEAT light does not go off with the instrument switch | → The SSR has failed “ON” | → Check for an accidental wiring fault which could have overloaded the SSR |

7.0 **CIRCUIT DIAGRAMS**

7.1 **Rotary Reactor: 208V-240V**

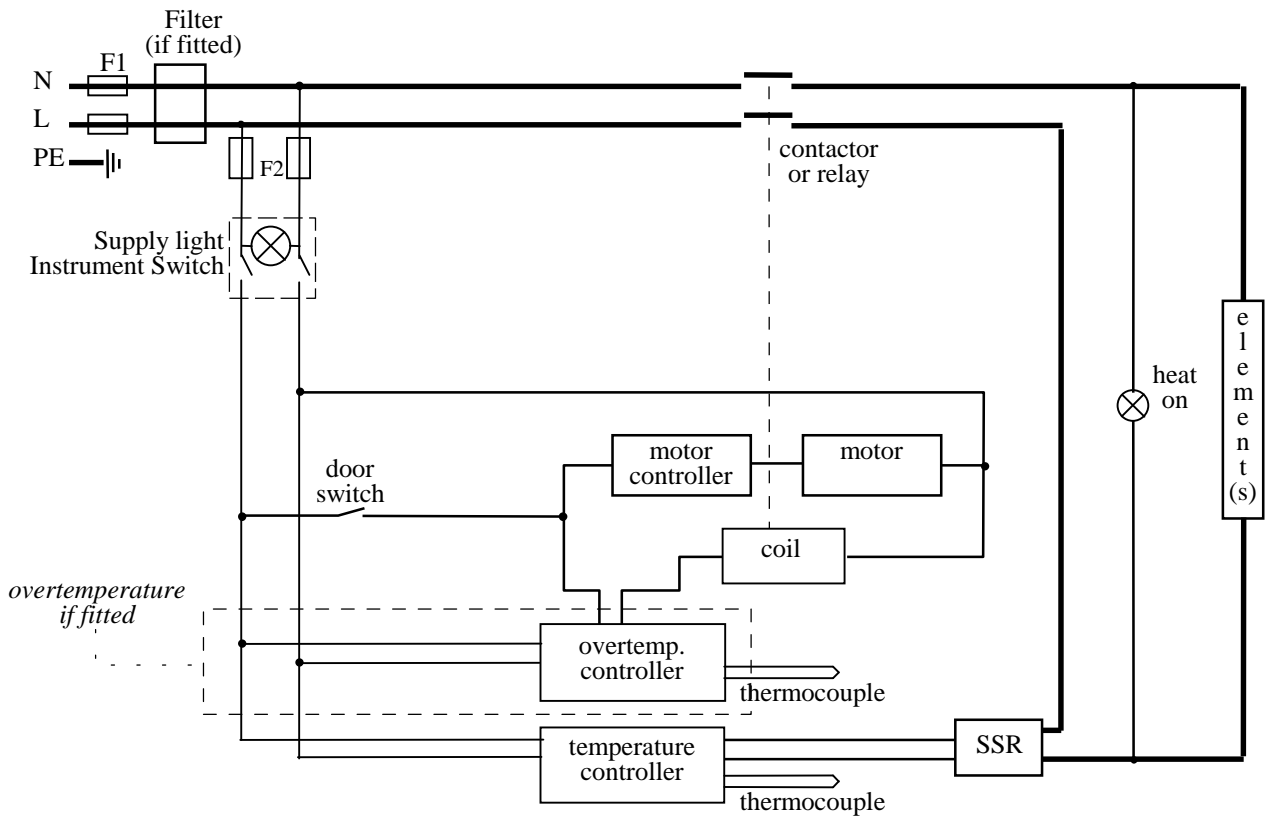

7.2 Rotary Reactor: 110-120V

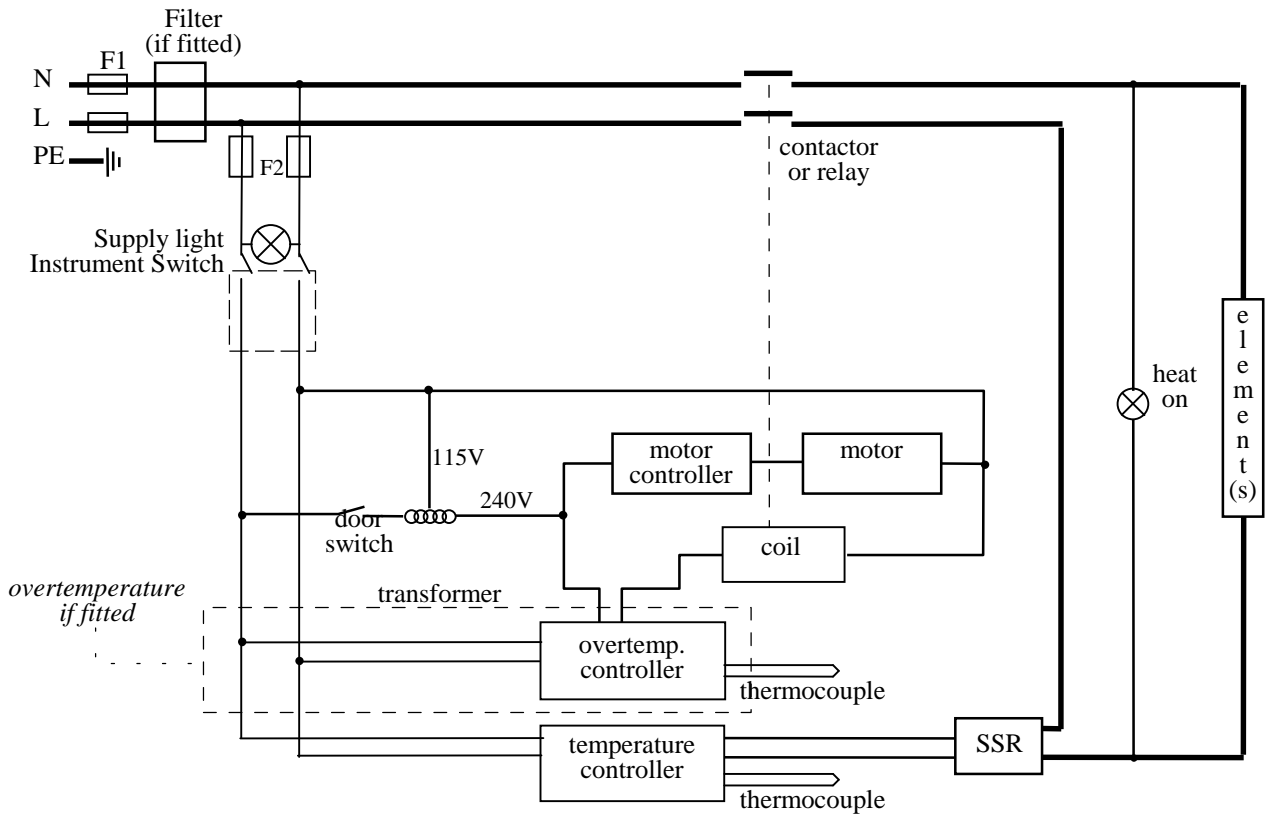

8.0 FUSES & POWER SETTINGS

8.1 Fuses

F1-F3: Refer to the circuit diagrams.

<i>F1</i>	Internal supply fuses	Fitted if supply cable fitted. Fitted on board to some types of EMC filter.	on-board and up to 16 Amps: 32mm x 6mm type F other: GEC Safeclip
<i>F2</i>	Auxiliary circuit fuses	Fitted on board to some types of EMC filter. May be omitted up to 25Amp/phase supply rating.	2 Amps glass type F On board: 20mm x 5mm Other: 32mm x 6mm
<i>F3</i>	Heat Light fuses	May be omitted up to 25 Amp/phase supply rating.	2 Amps glass type F 32mm x 6mm
	Customer fuses	Required if no supply cable fitted. Recommended if cable fitted.	See rating label for amperage; see table below for fuse rating.

Access to internal fuses is by removal of the back panel of the furnace base or control box.

Model	phases	Volts	Supply Fuse Rating	Volts	Supply Fuse Rating
HTR 11/75	1-phase	200-240	10A	110-120	16A
HTR 11/150	1-phase	220-240	12.5A	110-120	25A

other models or voltages: check the rating label for details of the supply.

8.2 Power Settings

The following values of the \overline{DPH} parameter apply.

Do not increase the setting beyond the value in the table: the wiring and the elements are designed on the basis of the declared settings.

Model	Volts:	200V	208V	220V	230V	240V	110V	115V	120V
HTR 11/75		100	100	89	81	75	89	82	75
HTR 11/150 (before year 2001)		100	100	100	100	100			
HTR 11/150 (year 2001 on)		100	100	89	81	75			

9.0 SPECIFICATIONS

Carbolite reserves the right to change specifications without notice.

9.1 Models Covered by this Manual

MODEL	Max. Temp. (°C)	Max. Power (kW)	Vessel Capacity (gm)	Net Weight (approx.) (kg)
<i>High temperature Rotary Reactor Heated by resistance wire embedded in ceramic fibre</i>				
HTR 11/75	1100°C	1.5	120	53
HTR 11/150	1100°C	2.6	950	100

9.2 Environment

The furnaces contain electrical parts and should be stored and used in indoor conditions as follows:

temperature: 5°C - 40°C
relative humidity: maximum 80% up to 31°C decreasing linearly to 50% at 40°C

The products covered in this manual are only a small part of the wide range of ovens, chamber furnaces and tube furnaces manufactured by Carbolite for laboratory and industrial use. For further details of our standard or custom built products please contact us at the address below, or ask your nearest stockist.

For preventive maintenance, repair and calibration of all Furnace and Oven products, please contact:

Thermal Engineering Services

Telephone: UK: 0845 3308035 Int: +44 1433 623335
Fax: UK: 0845 3308036 Int: +44 1433 623336
Email: service@thermalservice.com



MF30-3.03

7/12/00

HTR

Carbolite, Parsons Lane, Hope, Hope Valley, S33 6RB, England.

Telephone: (01433) 620011

Int: +44 1433 620011

Facsimile: (01433) 621198

Int: +44 1433 621198

E-mail: info@carbolite.com