

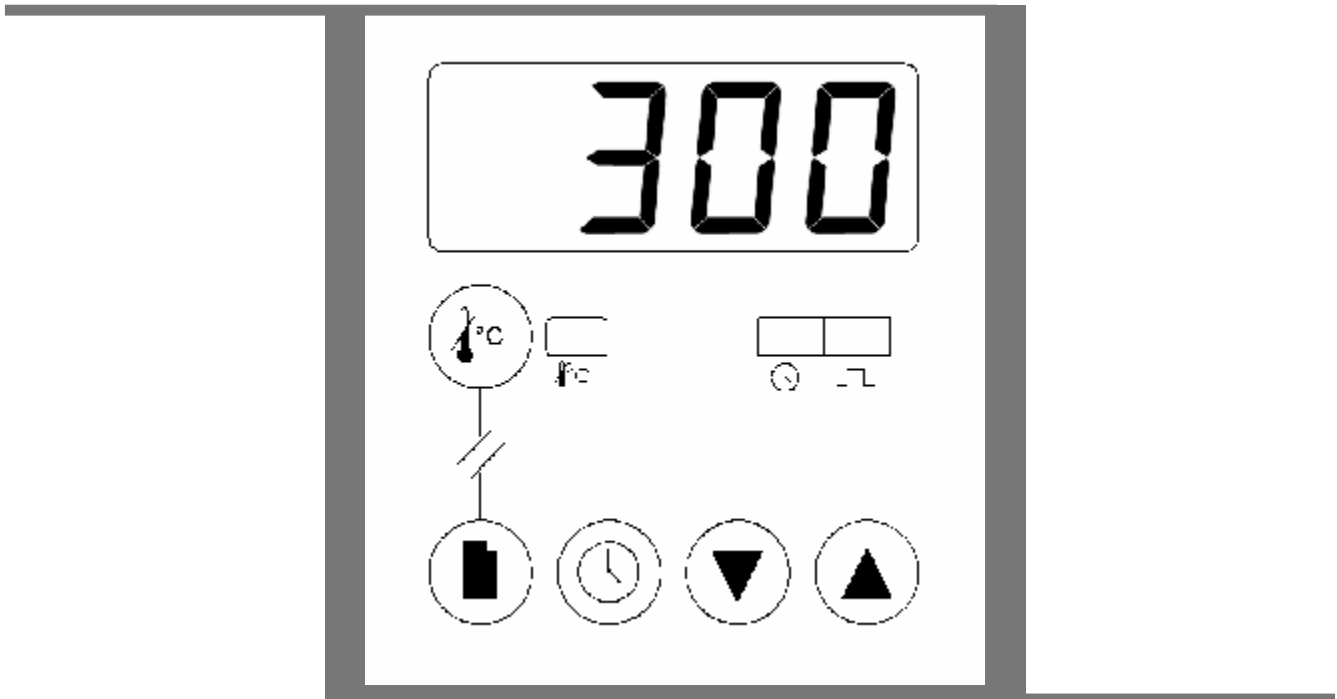

Operating Instructions

Temperature Controller



Type 300

English / °C

Contents

| | | |
|----------|--|-----------|
| 1 | Introduction to the Controller and Manual | 4 |
| 1.1 | Using This Manual | 4 |
| 1.2 | On/Off Control | 4 |
| 1.3 | Key Stroke Diagrams | 4 |
| 2 | Basic Operation | 5 |
| 2.1 | Keys | 5 |
| 2.2 | Indicators | 5 |
| 2.3 | Menu System | 5 |
| 2.4 | Home display | 6 |
| 2.4.1 | Finding the Home display from the Home menu | 6 |
| 2.4.2 | Finding the Home screen from the Set up menu | 6 |
| 2.5 | Hold Mode | 6 |
| 2.6 | Checking the Temperature Setpoint from the Home display | 7 |
| 2.7 | Changing the Temperature Setpoint | 7 |
| 2.8 | Changing the Timer Time | 7 |
| 3 | Advanced Operation | 8 |
| 3.1 | Entering the Set Up menu | 8 |
| 3.2 | Changing the Timer Band | 8 |
| 3.3 | Changing the Customer Calibration Type | 8 |
| 3.4 | Calibration Password | 9 |
| 4 | The Timer | 9 |
| 4.1 | Starting the Timer | 9 |
| 4.2 | Checking the time remaining | 9 |
| 4.3 | Pausing The Timer | 9 |
| 4.4 | Resetting The Timer | 9 |
| 4.5 | Timer Function Description | 10 |
| 4.6 | The Timer Temperature Band | 10 |
| 4.7 | Timer Function Table | 10 |
| 4.8 | Audible alarm types | 10 |
| 4.9 | Audible Alarm Cancel | 10 |
| 5 | Maximum Output Setting | 11 |
| 6 | Customer Calibration | 12 |
| 6.1 | Factory Calibration - <i>FACT</i> | 12 |
| 6.2 | Single Point Calibration - <i>CCL1</i> | 12 |
| 6.2.1 | Changing the Single Point Calibration Offset <i>OFFSE</i> | 12 |
| 6.3 | Dual Point Calibration - <i>CCL2</i> | 13 |
| 6.4 | Changing the Calibration, Low Temperature - <i>CALL</i> | 13 |
| 6.5 | Changing the Calibration, Low Temperature Offset - <i>OFFSL</i> | 13 |
| 6.6 | Changing the Calibration, High Temperature - <i>CALH</i> | 14 |
| 6.7 | Changing the Calibration, High Temperature Offset - <i>OFFSH</i> | 14 |
| 7 | Overtemperature protection | 15 |
| 7.1 | Overtemperature (O/T) Home Display | 15 |
| 7.1.1 | Finding the O/T Home Display from the O/T Home Menu | 15 |

| | | |
|-----------|---|-----------|
| 7.1.2 | Finding the O/T Home Display from the O/T Setup Menu..... | 15 |
| 7.2 | Changing the Overtemperature Limit | 16 |
| 7.3 | Checking the Overtemperature sensor temperature | 16 |
| 7.4 | Overtemperature Protection Calibration..... | 16 |
| 7.5 | Overtemperature Activation | 17 |
| 7.6 | Resetting Overtemperature Activation | 17 |
| 8 | RS232 Communication | 17 |
| 8.1 | RS232 Communication Addressing: | 17 |
| 9 | Navigation Diagrams | 18 |
| 10 | Controller Fault..... | 19 |
| 10.1 | Fault Code Diagnostic Table..... | 19 |
| 11 | Glossary of Terms | 19 |

1 Introduction to the Controller and Manual

1.1 Using This Manual

This manual aims to explain how to set up and operate the Eurotherm 300 controller; it must be read in conjunction with the product main manual.

Due to the complex nature of furnace or oven control the use of technical terms throughout this manual is unavoidable. Explanations of these terms can be found in the 'Glossary of Terms' at the back of this manual.

1.2 On/Off Control

The 300 controller uses On/Off temperature control. This type of control switches the elements on or off depending on the temperature of the furnace

1.3 Key Stroke Diagrams

Throughout this manual, key stroke diagrams are used to quickly describe the key presses required on the controller to alter the desired value.

 This symbol denotes a single press of the *Page* Key

 This symbol denotes a single press of the *Up* Key or the *Down* Key

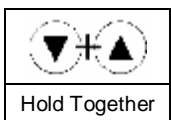
 This symbol denotes a single press of the *Up* Key and the *Down* Key for 1.5 Secs
Hold Together

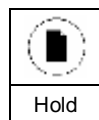
 This symbol denotes pressing and holding the *Page* key for 1.5 seconds



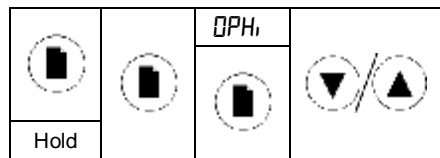

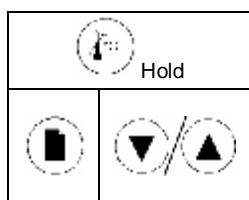
Examples of key press sequences:

 These symbols denote holding the *Page* key for 1.5 seconds, pressing the *Page* key twice (*OPH* should be showing on the display) then pressing the *Up* or *Down* arrow key.

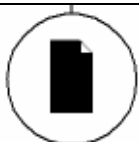

 These symbols denote holding the *Overtemperature* key down while pressing the *Page* key, followed by the *Up* or *Down* arrow key.

2 Basic Operation

2.1 Keys

| | | |
|---------------------|---|--|
| Page Key |  | The <i>Page</i> key is used to scroll through the parameters and switch between menus. |
| Timer Key |  | The <i>Timer</i> key is used to start, view, pause and reset the timer. |
| Arrow Keys |   | The <i>Arrow</i> keys are used to adjust the value of the selected parameter and pause the output power. |
| Overtemperature Key |  | The <i>Overtemperature</i> key is used to access the Overtemperature menu. |

2.2 Indicators

| | | |
|---------------------------|---|---|
| Output Indicator |  | The <i>Output</i> indicator shows when the controller is sending power to the elements. |
| Timer Indicator |  | The <i>Timer</i> indicator shows when the timer is active. |
| Overtemperature Indicator |  | The <i>Overtemperature</i> indicator shows green in normal use. It flashes red when overtemperature is triggered and is constantly red when overtemperature is reset and waiting for the temperature to drop. |

2.3 Menu System

The Eurotherm 300 controller is divided into two menus; the home menu and the set up menu. The home menu contains all the basic operating controls: setpoint and timer time. The set up menu contains all the set up features: timer type, output power and customer calibration. The features available vary depending on user input or product specification.

2.4 Home display

The Home display is the first display you see when the controller is switched on. It shows the actual temperature of the furnace or oven and will be referred to as PV throughout this manual. If you enter the menus, the controller will automatically return to the Home display if no keys are pressed for 30 seconds.

2.4.1 Finding the Home display from the Home menu

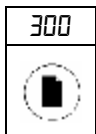

Press the *Page* key until the PV is shown on the display (300 shown as example).

2.4.2 Finding the Home screen from the Set up menu

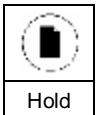

Press and hold the *Page* key for 1.5 seconds

2.5 Hold Mode

Hold mode turns the output off; this allows for parameters to be set without the controller instantly trying to control at the new settings.

Hold mode is shown on the display by the output indicator being off and the home display flashing between the PV and *HOLD*.

To enter Hold mode:

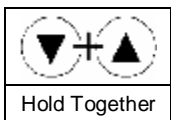

Start at the Home display

Press and hold the *Up* and *Down arrow* keys together for 1.5 seconds.

The display will flash *HOLD* to show that hold mode has been entered.

To exit Hold Mode:

Start at the Home display.

Press and hold the *Up* and *Down arrow* keys together for 1.5 seconds *OR* start the timer (See section 4).

Note: The Hold Mode function is disabled when the Timer function is running.

2.6 Checking the Temperature Setpoint from the Home display

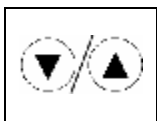

Start at the Home display

Press an *Up* or *Down* arrow key.

The display will then flash **SP°C** 3 times.

The Setpoint will show on the display for 3 seconds before returning to the Home display.

2.7 Changing the Temperature Setpoint

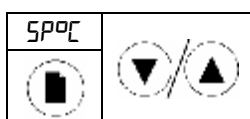

Start at the Home display

Press the *Page* key to scroll through the home menu until **SP°C** shows on the display

Use the *Up* and *Down* arrow keys to alter the value (°C) – a single press shows the current setting, To alter, either keep pressed or press again.

The value will then be stored without any further input.

Changing the Temperature Setpoint Ramp

2.8 Changing the Timer Time

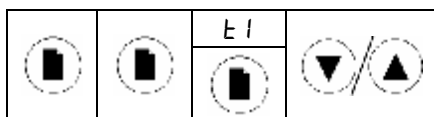

Start at the Home display.

Press the *Page* key to scroll through the home menu until **E I** shows on the display.

Use the *Up* and *Down* arrow keys either to switch off or alter the value (Hr:Min) – a single press shows the current setting. To alter either keep pressed or press again.

The value will then be stored without any further input.

See section 4 for more information on The Timer.

3 Advanced Operation

3.1 Entering the Set Up menu

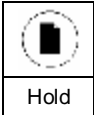

Start at the Home display.
 Press and hold the *Page* key for 1.5 seconds
 The display will change to the first parameter in the set up menu.

3.2 Changing the Timer Band

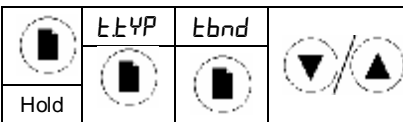

Start at the Home display.
 Press and hold the *Page* key for 1.5 seconds to enter the set up menu.
 Press the *Page* key until *t.bnd* shows on the display.
 Use the *Up* and *Down* arrow keys either to turn off or alter the value – a single press shows the current setting, To alter, either keep pressed or press again.
 The value will then be stored without any further input.

See section 4.6 for more information on The Timer Temperature Band.

3.3 Changing the Customer Calibration Type

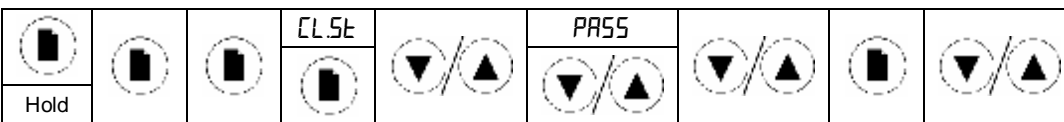

Start at the Home display.
 Press and hold the *Page* key for 1.5 seconds to enter the set up menu.
 Press the *Page* key until *CLSE* shows on the display.
 Press the *Up* or *Down* arrow key to display the current calibration type -
 (*FACT*, *CLL1* or *CLL2*)
 Press the *Up* or *Down* arrow key to display the password screen.
 Press the *Up* or *Down* arrow keys to enter the Calibration Password (Section 3.4).
 Press the *Page* key to confirm the password.
 Use the *Up* and *Down* arrow keys to select the calibration type.
 The value will then be stored without any further input.

See Section 8 for more information on Customer Calibration.

3.4 Calibration Password

Once entered the calibration password remains active for 30 seconds after leaving the setup menu to allow time to revisit if necessary.

The Calibration Password for this instrument is: **525**

4 The Timer

4.1 Starting the Timer



Start at the Home display.
Press the *Timer* key once to start the timer.

If you are in Hold Mode, pressing the timer key will automatically exit Hold Mode and the controller will start to run.

4.2 Checking the time remaining



While the Timer is running
Start at the Home display
Press the *Timer* key once to check the time remaining.
The display will then flash **⌂** 3 times.
The time remaining will show on the display for 3 seconds before returning to the home display.

4.3 Pausing The Timer

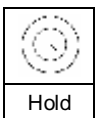

Start at the Home Display
Press and hold the *Timer* key for 1.5 seconds.

4.4 Resetting The Timer



When the Timer count has ended or the timer is paused.
Start at the Home display
Press and hold the *Timer* key for 1.5 seconds
⌂ is displayed to indicate timer reset.

4.5 Timer Function Description

The 300 controller has an in-built timer:

Timer Type $t1$

On pressing the *Timer* key; Timer Type 1 waits for the setpoint to be reached, then begins the countdown. On completion of the countdown, the furnace or oven switches off (End flashes on the display).

4.6 The Timer Temperature Band

Timer type $t1$ starts the count down when the setpoint temperature is reached. It is possible to set the timer going before setpoint is reached by adjustment of the timer temperature band $t.bnd$. e.g. $t.bnd$ set to a value of 3 will result in the timer starting to count down 3°C before the temperature setpoint is reached. This is practically useful when furnaces or ovens that take a long time to reach setpoint are at a sufficiently high temperature for a given customer process to occur.

4.7 Timer Function Table

| $t.tYP$ | | On Pressing the <i>Timer</i> key | During the Countdown | On completion of the Countdown |
|---------|-----------------|--|----------------------|--------------------------------|
| $t1$ | Output | On | On | Off |
| | Timer | Starts when Setpoint reached | Counts Down | Off |
| | Display | Flashes $t1$ 3 times. Shows Time left for 3 secs. | PV | Cycling PV / End |
| | Timer Indicator | Flashing until setpoint reached | On | Off |

4.8 Audible alarm types

The 300 controller can be supplied with an audible alarm. This alarm is linked into the timer types described in section 4.5. How the alarm triggers depends on the timer type selected:

Timer Types $t1$

When the timer reaches its end point, the alarm bleeps for 5 seconds at 10-second intervals. This is repeated for 5 minutes before cancelling itself.

4.9 Audible Alarm Cancel

To cancel an the audible alarm, press the *Timer* key.

5 Maximum Output Setting

Depending on the furnace or oven model the maximum output power setting $\square PH_i$ may be accessible or hidden.

For silicon carbide heated furnaces the parameter is accessible to allow compensation for element ageing, refer to the product manual for details.

In many models the maximum output power setting depends on the supply voltage, refer to the product manual for details.

6 Customer Calibration

The controller is calibrated for life at manufacture, there may however be sensor or other system errors which affect the accuracy of the measured temperature. Customer calibration is used to compensate for these errors.

The 300 controller has three types of customer calibration: factory calibration, single point calibration and dual point calibration.

6.1 Factory Calibration - FACt

Factory calibration is the default setting, which has no offset adjustment. It simply displays the temperature measured by the control thermocouple.

6.2 Single Point Calibration - CLL 1

Single point calibration uses an offset value to adjust the temperature over its whole range. Single point calibration accurately sets the temperature for setpoint values close to the temperature at which the calibration offset is made. This accuracy is reduced for setpoint temperatures which are significantly higher or lower than this.

Table showing examples of how to determine offset values

| Measured Calibration temp (°C) | Displayed temp (°C) | Old Offset Value (°C) | New Offset Adjustment | New Offset Value (°C) |
|--------------------------------|---------------------|-----------------------|-----------------------|-----------------------|
| 252 | 250 | 0 | 2 | 2 |
| 248 | 250 | 0 | -2 | -2 |
| 252 | 250 | 2 | 2 | 4 |

The calibration temperature may be measured at the centre of the chamber or through a specially fitted port.

New Offset Value = Old Offset Value + New Offset adjustment

New Offset Adjustment = Measured Calibration Temperature – Displayed Temperature



Caution! - The procedure to determine the calibration temperature at the centre of a chamber is not covered in these instructions. If you are unsure how to do this safely, then seek advice as there is a risk of electric shock if done incorrectly.

6.2.1 Changing the Single Point Calibration Offset OFFSt

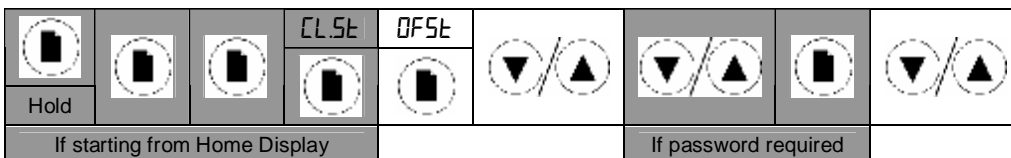

Starting from CLSt after CLL 1 has been selected. Press the *Page* key until OFFSt shows on the display.

Press the *Up* or *Down arrow* key to display the current calibration offset.
 Press the *Up* or *Down arrow* key to change the offset value.
 The value will then be stored without any further input.

Once the $\lll 1$ has been selected as the customer calibration type, it is possible to start from the Home display and go to OFFSE directly and enter the password at this point when the calibration adjustment is required again.

6.3 Dual Point Calibration - $\lll 2$

Dual point calibration uses two offset values at two corresponding temperatures to progressively change the calibration as the temperature increases or decreases. This is a more accurate representation of how the temperature difference will occur.

 **Caution!** - Do not make CAL.L and CAL.H the same value as the controller will not work correctly and could cause your furnace or oven to overheat.

6.4 Changing the Calibration, Low Temperature - CAL.L

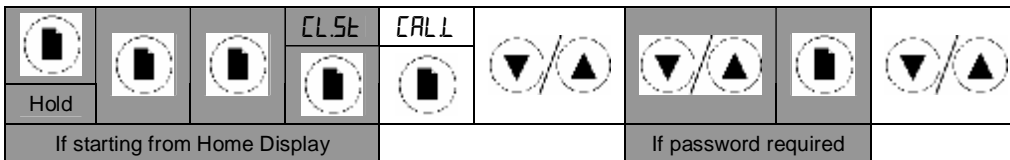

Starting from CLSE after $\lll 2$ has been selected.
 Press the *Page* key until CAL.L shows on the display.
 Press the *Up* or *Down arrow* key to display the current calibration low temperature.
 Press the *Up* or *Down arrow* key to change the temperature value.
 The value will then be stored without any further input.

Once $\lll 2$ has been selected as the customer calibration type, it is possible to start from the Home display and go to CAL.L directly (or any of the other settings in $\lll 2$) and enter the password at this point when calibration adjustment is required again.

6.5 Changing the Calibration, Low Temperature Offset - OFFSL

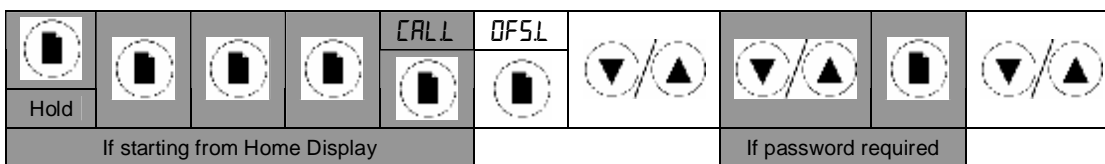

OFFSL follows on from CAL.L when the *Page* key is pressed.
 Press the *Up* or *Down arrow* key to display the current calibration low offset.
 Press the *Up* or *Down arrow* key to alter the low offset value.
 The value will then be stored without any further input.

6.6 Changing the Calibration, High Temperature – CALH

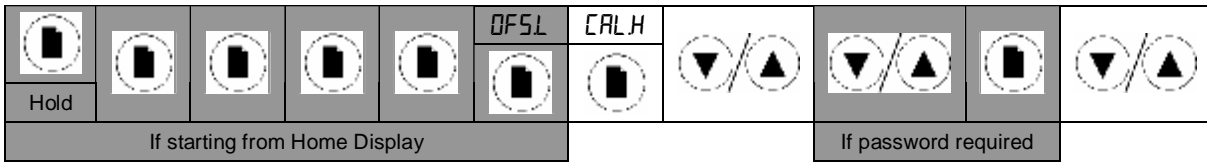

CALH follows on from **DFS.L** when the *Page* key is pressed.
 Press the *Up* or *Down arrow* key to display the current calibration low offset.
 Press the *Up* or *Down arrow* key to change the temperature value.
 The value will then be stored without any further input.

6.7 Changing the Calibration, High Temperature Offset - DFS.H

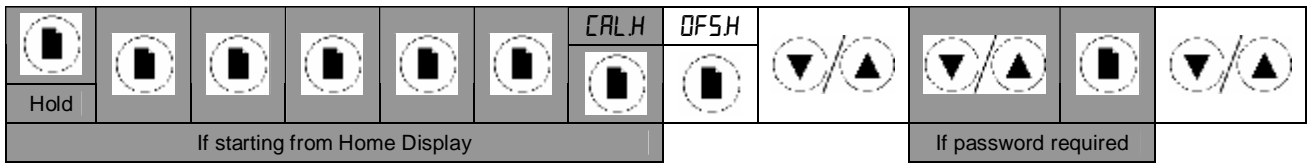

DFS.H follows on from **CALH** when the *Page* key is pressed.
 Press the *Up* or *Down arrow* key to display the current calibration offset.
 Press the *Up* or *Down arrow* key to alter the high offset value.
 The value will then be stored without any further input.

7 Overtemperature protection

Overtemperature protection is an option on the 300 controller. An independent control circuit and temperature sensor provide the over temperature protection.

There are two reasons for overtemperature protection:

1. To prevent the material being used in a furnace or oven from over-heating.
2. To give an extra safety system to prevent the furnace or oven from heating in the event of a fault.

7.1 Overtemperature (O/T) Home Display

When the Overtemperature key is pressed and held the O/T Home display is shown. The Home display shows what the overtemperature limit value is.

7.1.1 Finding the O/T Home Display from the O/T Home Menu

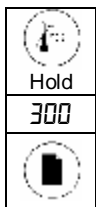

Press and hold the *Overtemperature* Key.

Press the *Page* key until the O/T limit value shows on the display

7.1.2 Finding the O/T Home Display from the O/T Setup Menu

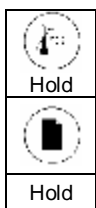

Press and hold the *Overtemperature* key

Press and hold the *Page* key for 1.5 seconds.

7.2 Changing the Overtemperature Limit

Note: If protection of the sample being processed is required, the overtemperature limit is normally set 15°C above the temperature setpoint of the controller. If protection of the furnace or oven is required, the overtemperature limit is normally set 15°C above the maximum setpoint of the furnace or oven.

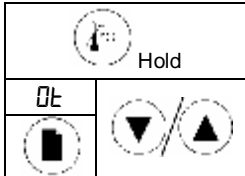

Start at the Home display.

Press and hold the *Overtemperature* key.

Press the *Page* key until **OL** shows on the display.

Use the *Up* and *Down* arrow keys to change the offset value— a single press shows the current setting. To alter either keep pressed or press again.

The value will then be stored without any further input.

7.3 Checking the Overtemperature sensor temperature

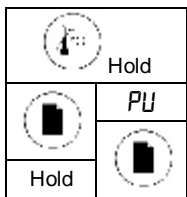

Starting at the Home display.

Press and hold the *Overtemperature* key.

Press and hold the *Page* key for 1.5 sec.

PU is displayed for 1 second, followed by the overtemperature sensor value for 3 seconds; this sequence is then repeated.

7.4 Overtemperature Protection Calibration

The overtemperature protection circuit can be calibrated in the same way as can the main controller. However, this is not normally necessary as the level of accuracy required for overtemperature protection is not as critical as it is for the main control temperature.

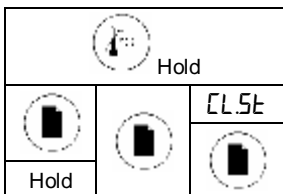

Starting at the Home display.

Press and hold the *Overtemperature* key.

Press and hold the *Page* key for 1.5 sec.

Press the *Page* key until **CL5t** is displayed.

Now follow the procedure in section 8

7.5 Overtemperature Activation

When an overtemperature circuit is fitted and is operating, the overtemperature indicator is green. When the temperature of the furnace or oven goes above the overtemperature limit, the overtemperature circuit activates. The power supply to the heating elements is cut and the overtemperature indicator changes to flashing red.

Pressing the Overtemperature key shows **OLT** in the display to say that the overtemperature has been triggered.

The reason for the overtemperature activation should then be investigated; an incorrect setting in the overtemperature limit is often the cause. When you are satisfied with the reason for the overtemperature activation it can be reset.

7.6 Resetting Overtemperature Activation

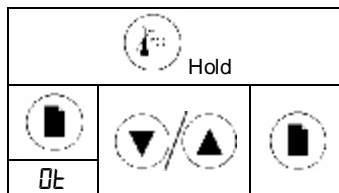

Starting at the Home display press and hold the Overtemperature key; **OLT** is displayed.

Press the *Page* key; **OLT** is displayed and the red indicator stops flashing.

Press the *Up* or *Down arrow* key to check the overtemperature limit value.

Press the *Up* or *Down arrow* key to alter the value if necessary.

Press the *Page* key to return to the overtemperature home display.

The overtemperature has now been reset

When the temperature falls below the overtemperature limit, the indicator changes back to green.

When the PV falls below the temperature setpoint, the furnace/oven starts to heat again.

8 RS232 Communication

The 300 controller can be supplied with the capability to communicate with other devices via an RS232 link. If this option has been ordered, the furnace or oven will be supplied with a 9 pin 'D' socket for connecting to an external device. Plugging this into a computer will allow the controller to be accessed from that computer. The computer must have appropriate communication software installed such as Eurotherm's 'i-Tools'

8.1 RS232 Communication Addressing:

| | | |
|----------------|---|-------------|
| Modbus Address | = | 1 |
| Baud Rate | = | 9600 |
| Byte Format | = | 8 |

9 Navigation Diagrams

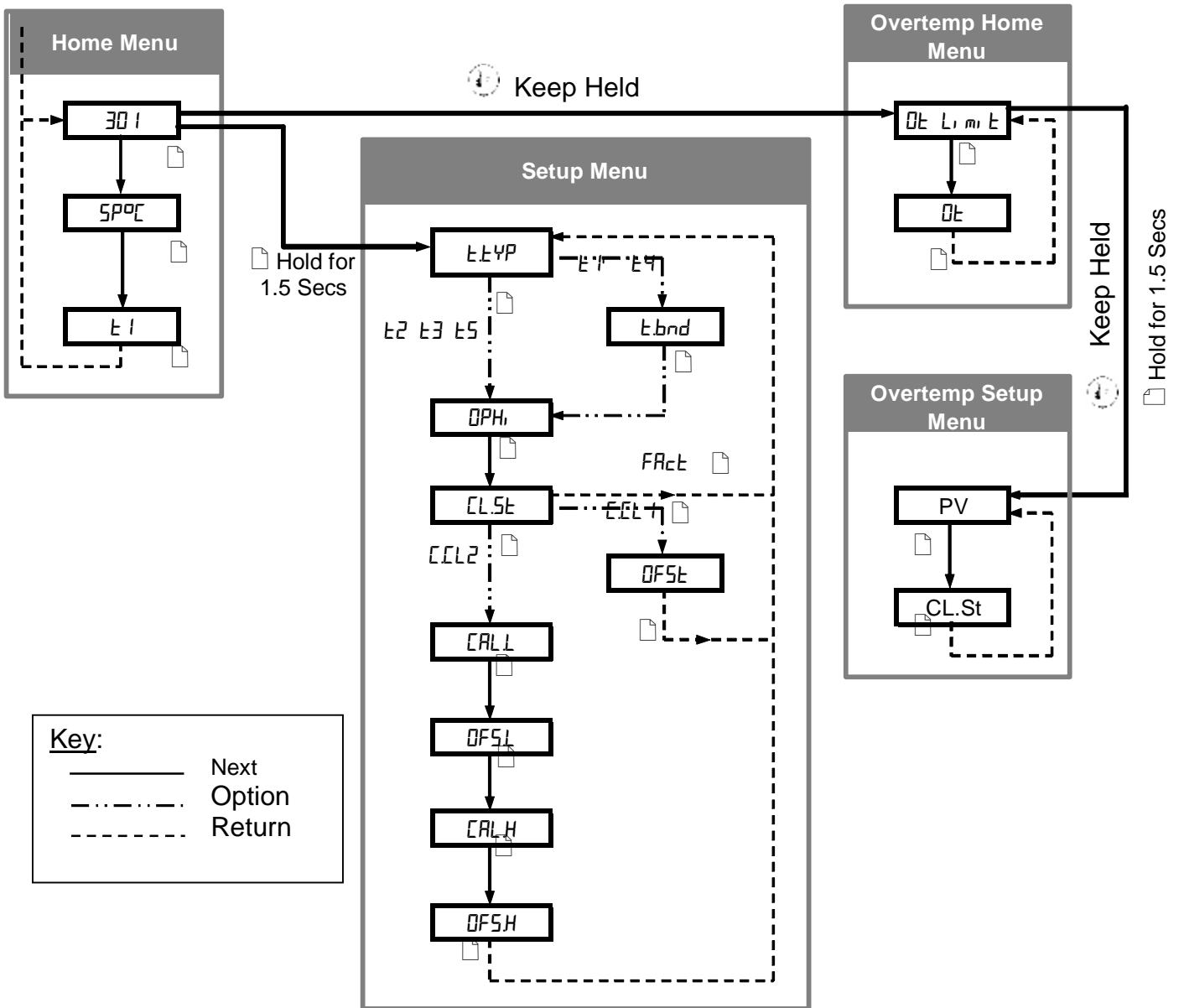

10 Controller Fault

10.1 Fault Code Diagnostic Table

| Error Code | Explanation | Actions |
|--------------------------------|----------------------------|--|
| 5br | Temperature sensor failure | Replace the Furnace or Oven Temperature Sensor |
| E - followed by numerical code | Controller Error | Turn Furnace or Oven off and back on to see if this clears the error. If not contact Thermal Engineering Services – (see back cover) |

11 Glossary of Terms

| | | |
|----------------------------|--|--------|
| Process Value (PV) | The actual temperature of the furnace or oven. | °C |
| Setpoint (SP) | The target temperature the furnace or oven is trying to reach. | °C |
| Setpoint Ramp Rate | The speed at which the furnace or oven is allowed to heat up or cool down. | °C/Min |
| Element | The heating device used in the furnace or oven. | - |
| Thermocouple | The temperature measuring device used in the furnace or oven. | - |
| PID | Proportional Integral Derivative: the control system used by the controller. | - |
| Overtemperature (O/T) | The condition which a furnace or oven may enter if part of the main control circuit fails. | - |
| Overtemperature Protection | A system to prevent the product or process being damaged if it has gone into an overtemperature condition. | - |
| Furnace or Oven | This refers to the product purchased from Carbolite. | - |

For preventive maintenance, repair and calibration of all Furnace and Oven products, please contact:

Thermal Engineering Services

Telephone: UK: 0845 3308035 Int: + 44 1433 623335
Fax: UK: 0845 3308036 Int: + 44 1433 623336
Email: service@thermalserve.com



MC17-GB-C – 1.00

20/12/04

Carbolite, Parsons Lane, Hope,
Hope Valley, S33 6RB, England.

Telephone: (01433) 620011

Int: + 44 1433 620011

Facsimile: (01433) 621198

Int: + 44 1433 621198

E-mail: info@carbolite.com