



# Installation, Operation & Maintenance Instructions

1700-1800°C Tube Furnaces  
types CTF & TZF

This manual is for the guidance of operators of the above Carbolite products and should be read before the furnace is connected to the electricity supply.

---

## CONTENTS

page		section
1.0	Symbols & Warnings	1
2.0	Installation	3
3.0	Operation	6
4.0	Maintenance	9
5.0	Repairs & Replacements	10
6.0	Fault Analysis	13
7.0	Circuit Diagram	13
8.0	Fuses & Power Control	15
9.0	Specifications	16

---

**Manuals for the furnace controller and overtemperature controller are supplied separately.**

Please read the controller manuals before operating the furnace.

**SYMBOLS & WARNINGS**

**1.1 Switches and Lights**



Supply Light: when the furnace is connected to the electrical supply the light in the adjacent switch glows

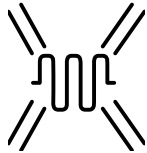

Heat Light: the adjacent light glows or flashes to indicate that power is being supplied to the elements

**1.2 Warning Symbols**

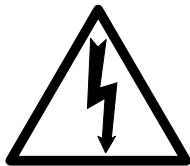

DANGER of electrical shock– read any warning printed by this symbol.



DANGER – hot surface. Read any warning printed by this symbol.  
WARNING: all surfaces of a furnace may be hot.

**2.0**

## **INSTALLATION**

### **2.1 Unpacking & Handling**

When unpacking or moving the furnace always lift it by its base. Never lift it by its work tube or the surrounding insulation, or by any protruding parts. These models contain transformers and are heavy: use of lifting equipment is recommended.

### **2.2 Siting & Setting Up**

Place the furnace in a well ventilated room, away from other sources of heat, and on a surface which is resistant to accidental spillage of hot materials. Do not mount the furnace on an inflammable surface.

Ensure that there is free space around the furnace. Do not obstruct any of the vents in the case: there are cooling fans in the case which must not be obstructed.

Ensure that the furnace is placed in such a way that it can be quickly switched off or disconnected from the electrical supply - see below.

### **2.3 Removal of Packing Material**

Remove the cover from the right hand side by slackening the fixing screws through the four access holes and lifting the cover vertically to release it.

Remove the end insulation retaining plate by unscrewing the four fixing screws and carefully sliding the plug from the brickbox.

Three pieces of insulation come away with the plate leaving two halves loose inside the furnace. Remove these to give access to the packing material therein. Carefully remove all packing material. Note that in the TZF models there are zone barriers comprising insulation pieces which protrude into the chamber; take care not to damage these pieces.

*Model TZF 18/600 – see separate booklet MS12.*

Reassemble the insulation by reversing the removal procedure. Now fit the heating elements.

### **2.4 Fitting the Heating Elements**



Wear eye protection when handling the heating elements. See the warning in section 5.7.

The Molybdenum Disilicide elements are EXCEPTIONALLY FRAGILE and are packed separately, together with other items:

<u>Separately packed items</u>	CTF 17/300	CTF 18/300	CTF 17/600 TZF 17/600	CTF 18/600 TZF 18/600
Elements	6	6	10	10
Element clamps	12	12	20	20
Element clips	12	12	20	20
Braids	1 set	1 set	1 set	1 set
Element insulators	6	6	10	10

Fit the heating elements vertically into the chamber, handling with great care. Installation instructions are given later in this manual in section 5.7.

Connect the aluminium braids securely as indicated in the element installation instructions.

### **2.5 Fitting the Thermocouples**

The number of thermocouples depends on the model. CTF has two, TZF has four or five depending on the 3-zone control method. The thermocouples are enclosed in ceramic sheaths which fit downwards through the roof in holes approximately 10mm. Each hole has a nearby terminal block.

Fit the sheaths into the holes. Fix the sheaths in place using a self-tapping screw through the wire in the nearby hole.

Insert the thermocouples and connect them to the terminal blocks. The leg of the thermocouple with a blue paint mark is the negative. The negative side of the connecting cable is marked with a double number (e.g. 11).

**2.6 Electrical Connections**

*Connection by a qualified electrician is recommended.*

The /300 models are designed only for single phase electrical supplies with or without neutral. The larger models may be made for 1- or for 3-phase use. The furnace must be connected only to the type and voltage of supply for which it was ordered.

The voltage or range of voltages on which the furnace may be operated is given on the furnace rating label. Check that the supply voltage is compatible with the voltage on the label, and that the current capacity is sufficient for the amperage on the label, before connection to the supply. A table of the most common ratings is given in section 8.1 of this manual.

The supply point must be within reach of the furnace operator and must incorporate either an isolating switch which operates on all live conductors, or a quickly removable plug.

The supply **MUST** incorporate an earth (ground).

CONNECTION DETAILS			<i>supply type</i>	
Supply	Terminal label	Cable colour	<i>Live-Neutral</i>	<i>Reversible or Live-Live</i>
<b>1-phase</b>	L	Brown	To live	to either power conductor
	N	Blue	To neutral	to the other power conductor
	PE	Green/Yellow	To earth (ground)	to earth (ground)
<b>3-phase</b>	L1	Black	to phase 1	
	L2	Black	to phase 2	
	L3	Black	to phase 3	
	N	Light Blue	to neutral <i>except delta</i>	
	PE	Green/Yellow	to earth (ground)	

**2.7 Inserting a Tube**

If a work tube is supplied with the furnace, then the hole through the insulation is correctly sized. Carefully line up the tube and ease it through the chamber. Using a pole such as a broom handle may help with this operation.

For a tube of customer supply, ensure that there is approximately 1mm of free play sideways and upwards. If the tube is too tight it will crack when heated. A tight hole can be eased by rotating the tube, which has a sufficiently abrasive surface. Remove loose dust with a domestic vacuum cleaner. Safety note: see section 5.2.

If the holes in the insulation are too large, please consult Carbolite for technical assistance.

If a long tube is specified, then a pair of cylindrical end-guards is supplied. Bolt these onto the furnace ends. The guards incorporate a hookbolt and strap arrangement for supporting the tube, to prevent failure from mechanical stress. These should be adjusted to take the weight of the tube without lifting it clear of the insulation.

**2.8**

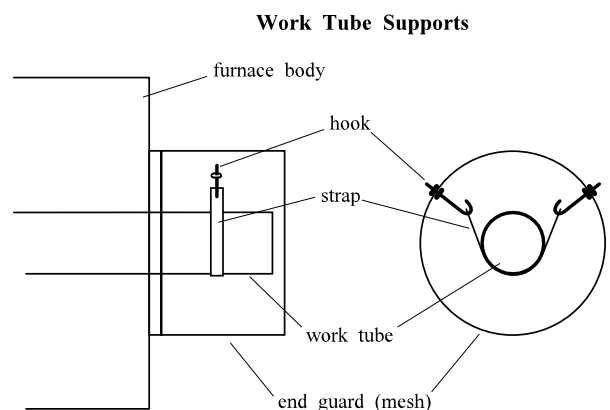

### **Internal Work Tube Supports**

Work tubes may sag at high temperatures. The furnace is fitted with internal tube supports which should be manually adjusted to suit the tube diameter.

With the tube fitted into the furnace, remove the back panel and identify the tube supports. In the /300 models, there is 1 support. In the /600 models, there are 3. Adjust each support in turn, as follows:

- loosen the ring clip using a screwdriver;
- push the ceramic tube upward until it just touches the bottom of the work tube;
- retighten the ring clip.

Note that it is advisable to lower the support tubes if the work tube is removed or replaced, and later readjust them.

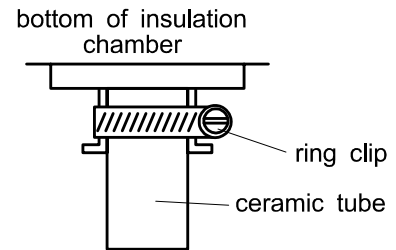

### **2.9 Tube Fittings (if ordered)**

For optimum temperature uniformity, insulating plugs should be placed in the tube ends as shown in fig.1. With a long work tube, the stem of the plug assembly should line up with the end of the tube as in fig.2. Alignment of radiation shields is similar to that of plugs.

If stainless steel seals with gas inlets are supplied they are to be fitted as shown in fig.3; the stem of any insulating plug or radiation shield should touch the seal.

If heavy fittings are to be clamped to the end of an extended work tube they can increase the bending stress at the centre of the tube. Support such fittings in such a way that expansion of the tube is allowed.

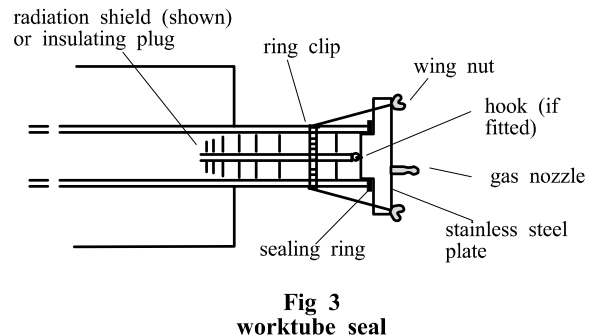
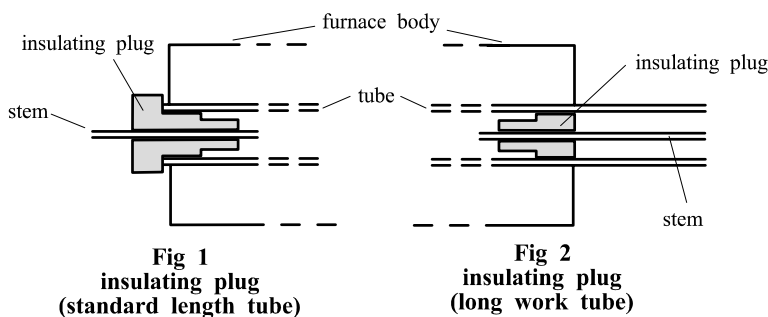

### **3.0**

### **OPERATION**

*The instructions for operating the temperature controller are given in a separate manual.*

*If the furnace is fitted with a time switch, see also the supplementary manual MS03.*

*If cascade control is fitted, see the supplementary manual MS07.*

#### **3.1 Operating Cycle (CTF models)**

The furnace is fitted with a combined Supply light and Instrument switch. The light is on whenever the furnace is connected to the supply. The switch cuts off power to the controllers and contactor.

Connect the furnace to the electrical supply. The Supply light should glow.

Operate the instrument switch to activate the temperature controller. The controller becomes illuminated and goes through a short test cycle.

Adjust the main temperature controller – see the controller manual.

Set the overtemperature controller to a temperature a little (say 15°C) above the maximum setpoint of program temperature, according to the instructions in the appropriate manual.

Unless a time switch is fitted and is off, the furnace starts to heat up. The Heat light(s) glow(s) brightly at first, more dimly as the furnace temperature approaches a program setpoint.

If the overtemperature trip operates then an indicator or message in the overtemperature controller flashes, and the heating elements are isolated. Find and correct the cause before resetting the overtemperature controller according to the instructions in the appropriate manual.

To turn the furnace off, set the Instrument switch to its off position; the controller display will go blank. If the furnace is to be left off unattended, isolate it the electrical supply.

#### **3.2 Operating Cycle (TZF)**

*See section 3.3 for a description of the control methods A, B & C.*

The furnace is fitted with a combined Supply light and Instrument switch. The light is on whenever the furnace is connected to the supply. The switch cuts off power to the controllers and contactor.

Connect the furnace to the electrical supply. The Supply light should glow.

Operate the instrument switch to activate the temperature controller. The controller becomes illuminated and goes through a short test cycle.

*Control methods A & B:* Set the slave (end zone) controllers to the desired offset temperature, usually zero. Set the main (central) temperature controller to the desired setpoint or program. See section 3.3 and the separate manual(s) for the controller(s).

*Control method C:* Set the three controllers to the desired temperatures. See the separate manual(s) for the controller(s).

Set the overtemperature controller to a temperature a little (say 15°C) above the maximum setpoint of program temperature, according to the instructions in the appropriate manual.

Unless a time switch is fitted and is off, the furnace starts to heat up. The Heat light(s) glow(s) brightly at first, more dimly as the furnace temperature approaches a program setpoint.

If the overtemperature trip operates then an indicator or message in the overtemperature controller flashes, and the heating elements are isolated. Find and correct the cause before resetting the overtemperature controller according to the instructions in the appropriate manual.

To switch the furnace off, set the Instrument switch to off. If the furnace is to be left off, isolate it from the electrical supply.

### 3.3 3-zone Control Methods

*Applicable to TZF only.*

The TZF is designed to achieve an extended uniform temperature zone by the use of three control zones. The control zones are typically linked so that they all follow the central controller in a master-slave approach; there are two ways of doing this. Alternatively independent control zones may be ordered. There are thus three control methods (A, B & C).

#### A. **Back-to-Back Thermocouples**

This is the default option for the 1700°C model.

The central zone is controlled directly by the central temperature controller. Each end zone thermocouple is wired in opposition to a central reference thermocouple, and the small voltage resulting when the zones are at different temperatures is used by the end zone controller. The circuit diagram in section 7.2 shows the thermocouple arrangement.

Set the "setpoint" of the end zone controllers to zero. To alter the setpoint (with the display at "home"), press Down ▼ or Up ▲ once to display the setpoint; press again or hold down to adjust it. The display returns to the measured temperature offset when no key is pressed for 0.5 seconds.

Sometimes a furnace using this type of control does not cool down: the end controllers try to remain at the central temperature. Should this occur, contact Carbolite's technical department.

#### 2132 Slave Controller Navigation Diagram

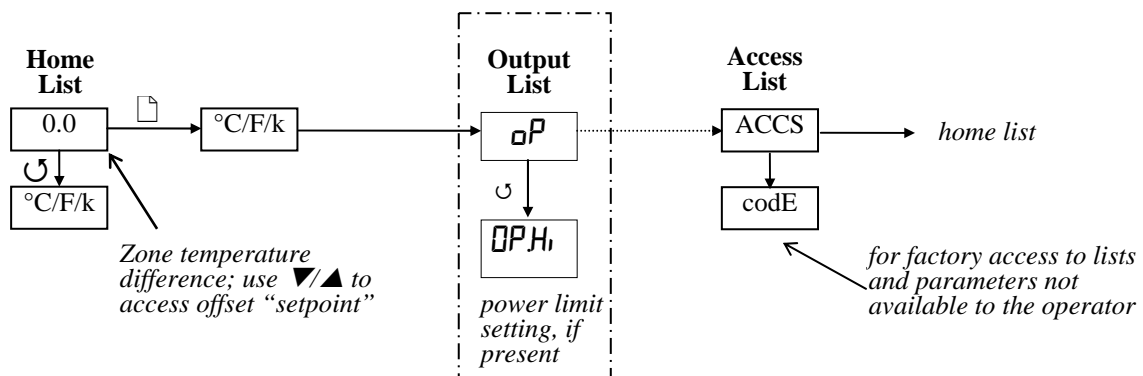

#### B. **Retransmission of Setpoint using Broadcast comms**

When this is ordered there are three independent thermocouples connected to the three controllers. The controllers are linked together, the central controller communicating the desired setpoint to the end controllers.

Additional communication modules are fitted in the controllers, rather than an additional thermocouple as in A. The communication between the controllers of the Eurotherm 3000 series is known as Broadcast comms.

It is possible to switch off the linked control and allow the controllers to work independently. In level 2 of the end zone controllers (see controller operating instruction), scroll to **L-r**. Where the end zone controller is a 3216 use the ▲ up ▼ down and select **NO**. Where the end zone controller is a 3508 use the ▲ up ▼ down to select **SP1**, (SP1 = Local, and SP2 = Remote). There is no need to alter the centre controller.

It is possible to use local trim in the end zone controllers to enter a positive or negative adjustment from the centre zone temperature. Once entered this trim will always be added or subtracted from the retransmitted set temperature. In level 2 of the end zone controller (see controller operating instruction), scroll to **LOC** (local trim) and use the ▲ up ▼ down enter the desired positive or negative difference to be added to the end zone set temperature. There is no need to alter the centre controller.

### C. Independent Control

In this case the three controllers are completely independent. Note that it is not possible to maintain very different zone temperatures because of heat transfer within the work tube.

### 3.4 General Operating Advice

Heating element life is shortened by use at temperatures close to maximum. Do not leave the furnace at high temperature when not required. The maximum temperature is shown on the furnace rating label and on the back page of this manual. The furnace can be cycled between room temperature and maximum without a detrimental effect on element life - but see the notes on tube life.

On first installing the elements, and on subsequent element replacement, run the furnace at 1500°C for an hour to create a protective glaze on the element surface.

The furnace elements are very susceptible to mechanical shock. Take great care when moving the furnace.

### 3.5 Operator Safety

Ceramic materials used in furnace manufacture can become conductive at high temperature. Avoid using conductive tools within the work tube without first isolating the elements. The elements are isolated (via a contactor) when the instrument switch is off.

If a metal work tube is used, it must be earthed (grounded). Note that the furnace temperature should be limited if a metal tube is used.

Ensure that there are no inflammable objects placed in such a way that the work tube could break and fall on them.

### 3.6 Tube Life

A ceramic work tube may crack if workpieces are inserted too quickly or at temperatures below 900°C (when the tube is more brittle). Large pieces should also be heated slowly to ensure that large temperature differences do not arise.

Poor thermal contact should be encouraged between the workpiece and the tube; crucibles or boats should be of low thermal mass and should have feet to reduce the contact with the tube (fig. 4).

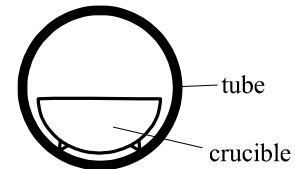

**Fig 4**  
**avoidance of thermal contact**

Avoid metal directly touching the work tube - see the safety warning above.

Do not set too high a heating rate. Large diameter tubes are more susceptible to thermal shock than smaller. A general rule for maximum heating rate is 400/internal diameter (°C/min); for 75mm i/d tubes this comes to 5°C per minute. The controller can be set to limit the heating rate.

### 3.7 Pressure

Work tubes are not able to accept high internal pressure. When gas seals or similar fittings are in use, the gas pressure should be restricted to a maximum of 0.2 bar (3 psi). A pressure of about half of that should normally be sufficient to achieve the desired flow rate. The customer must ensure that the exhaust path from the tube is not blocked, so that excess pressure does not occur.

### 3.8 Thermocouples - Warnings

- (1) The output from 1700-1800°C thermocouples when used regularly at temperatures greater than 1650°C can deteriorate and decrease with age.

Customers are advised periodically to check the thermocouple output, either by a calibration test, or by comparing the output with a new reference thermocouple which has been subjected to high temperatures for a minimum length of time.

Failure to check the thermocouple may result in overheating of the work and the furnace.

- (2) The thermocouples fitted to these models give very low outputs below about 600°C, and do not give accurate readings at low temperatures. The furnaces are not intended to be operated below 600°C.

## **4.0 MAINTENANCE**

### **4.1 Routine Maintenance**

No routine maintenance is required. The outer surfaces may be cleaned with a damp cloth. Do not allow water to enter the interior of the case, tube or control box. Do not clean with organic solvents.

### **4.2 Calibration**

After prolonged use the controller and/or thermocouple could require recalibration; see the warning about thermocouples in section 3.8. This would be important for processes which require accurate temperature readings or which use the furnace close to its maximum temperature. A quick check using an independent thermocouple and temperature indicator should be made from time to time to determine whether full calibration is required. Carbolite can supply these items.

Depending on the controller, the controller manual may contain calibration instructions.

### **4.3 After Sales Service**

Carbolite's service division (Thermal Engineering Services) has a team of Service Engineers capable of repair, calibration and preventive maintenance of furnace and oven products at our customers' premises throughout the world. We also sell spares by mail order. A telephone call or fax often enables a fault to be diagnosed and the necessary spare part despatched.

Each furnace has its own record card at Carbolite. In all correspondence please quote the serial number, model type and voltage given on the rating label of the furnace. The serial number and model type are also given on the front of this booklet when supplied with a furnace.

To contact Thermal Engineering Services or Carbolite see the back page of this manual.

### **4.4 Recommended Spares Kits**

Carbolite can supply individual spares, or a kit of the items most likely to be required. Ordering a kit in advance can save time in the event of a breakdown. Each kit comprises one thermocouple, one sheath, one power thyristor, and a set of elements, clips and braids. It is advisable also to obtain element clamps and insulators (not included in kit).

When ordering spares please quote the model details as requested above.

### **4.5 Power Adjustment (Controller)**

The furnace controller incorporates a power limit parameter  $\square PH_i$  which is usually inaccessible to the operator.

Occasionally the power limit is set to zero to permit demonstration of the controls without the heating elements taking power. In this case the power limit is accessible to the operator and may be reset to its standard value of 100.

### **4.6 Power Adjustment (Thyristor)**

The current-limiting thyristor stacks which control power to the elements are fitted with an adjustable resistor which is factory set to limit the maximum current supplied. In the event of a change of supply voltage, or the fitting of a new thyristor, further adjustment may be required.

The maximum element currents for the various models are listed in section 8.2. Please contact Carbolite for further information.

### **4.7 Work Tube Supports**

Occasionally the internal work tube supports may need adjusting. See section 2.8.

### 5.0 REPAIRS & REPLACEMENTS

#### 5.1 Safety Warning – Disconnection from Supply

Always ensure that the furnace is disconnected from the supply before repair work is carried out.

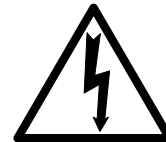

#### 5.2 Safety Warning - Refractory Fibrous Insulation

This furnace contains refractory fibres in its thermal insulation. These materials may be in the form of fibre blanket or felt, vacuum formed board or shapes, mineral wool slab or loose fill fibre.



Normal use of the furnace does not result in any significant level of airborne dust from these materials, but much higher levels may be encountered during maintenance or repair.

Whilst there is no evidence of any long term health hazards, we strongly recommend that safety precautions are taken whenever the materials are handled.

**Exposure to dust from fibre which has been used at high temperatures may cause respiratory disease.**

**When handling fibre always use an approved mask, eye protection, gloves and long sleeved clothing.**

**Avoid breaking up waste material. Dispose of waste fibre in sealed containers.**

**After handling rinse exposed skin with water before washing gently with soap (not detergent). Wash work clothing separately.**

Before commencing any major repairs we recommend reference to the European Ceramic Fibre Industry Association Bulletin No. 11 and the UK Health and Safety Executive Guidance Note EH46.

We can provide further information on request. Alternatively our service division can quote for any repairs to be carried out at your premises or ours.

#### 5.3 Temperature Controller Replacement

2132, 3216, 3508 etc. Ease apart the two lugs at the side; grip the instrument and withdraw it from its sleeve; push in the replacement.

#### 5.4 Fuse Replacement

Access to internal fuses is by removal of the furnace cover or back panel. See section 8.1 for details of fuses fitted.

#### 5.5 Thermocouple Replacement

Disconnect the furnace from the supply, and remove the top cover. In the case of TZF 18/600, remove the back panel, as the thermocouples are horizontal.

Make a note of the thermocouple connections. The negative leg of the thermocouple is marked blue. The “compensating” cable for 1700 & 1800°C thermocouples is plain copper.

Disconnect the thermocouple from its terminal block.

Bend the metal tag, or release the screw, to release the thermocouple sheath; withdraw the sheath, and shake out any fragments of thermocouple.

Re-assemble with a new thermocouple observing the colour coding, ensuring that the thermocouple is not twisted as it is being inserted and that the metal tag is bent back, or the screw inserted, to grip the sheath.

#### 5.6

## Insulation Replacement

After any replacement of insulation material, run the furnace at 1500°C to burn off volatile matter. Do this in a well ventilated area, without the work tube in place.

### 5.7 Element Installation & Replacement

*Safety Warning – Molybdenum Disilicide elements.*

*The elements form a glazed surface when heated. Internal stresses can form through heating and cooling which render the glaze fragile. The glaze can sometimes splinter into a shower of sharp particles when handled. Always wear eye protection when handling the elements.*



Handle the heating elements with extreme care as they are very fragile. Also, avoid touching the heating surface (the thin part of the element).

*Replacement:* Note the length of element above the fixing clamps before starting. Remove the aluminium braids and clips. Remove the clamp, which has a screw fixing. Lift out the old element and insulation piece (element block): handle the insulation piece with care as it is fragile.

The element diagram shows the items which must be assembled and fitted. Examine and identify the loose components. There are variations in the positions of the braids which connect the elements: the rule is that for single phase all elements are in series; for 3-phase or 3-zone, each phase or zone has elements in series.

Fit the insulation piece (element block) to the element. Locate the clamps over the element, and tighten carefully. Lower the element into position, and connect the braids using the clip tool provided or hand pressure, depending on the type of clip.

Ensure that the element is correctly placed: the thin part of the element legs should be entirely within the heating chamber; the element should not touch the bottom of the chamber, nor the work tube.

*Replacement:* heat up the furnace to a moderate temperature and ensure that the furnace is controlling properly, in case the previous element failure resulted from a fault in the control system.

After installing new elements run the furnace at 1500°C for an hour. This creates a protective glaze on the element surface.

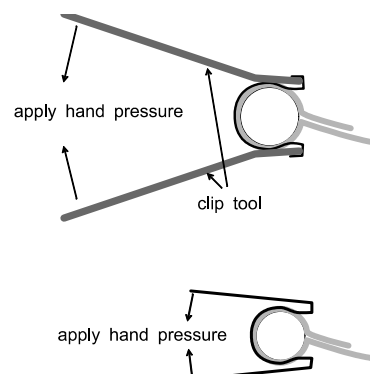
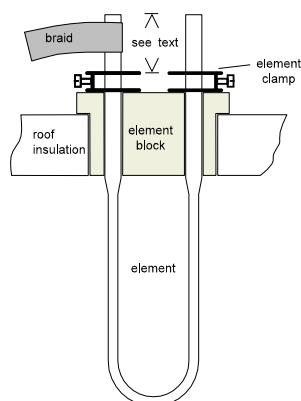

larger clips require clip tool, comprising two levers

smaller clips do not require clip tool

Element Connections

*Example: TZF 17/600*

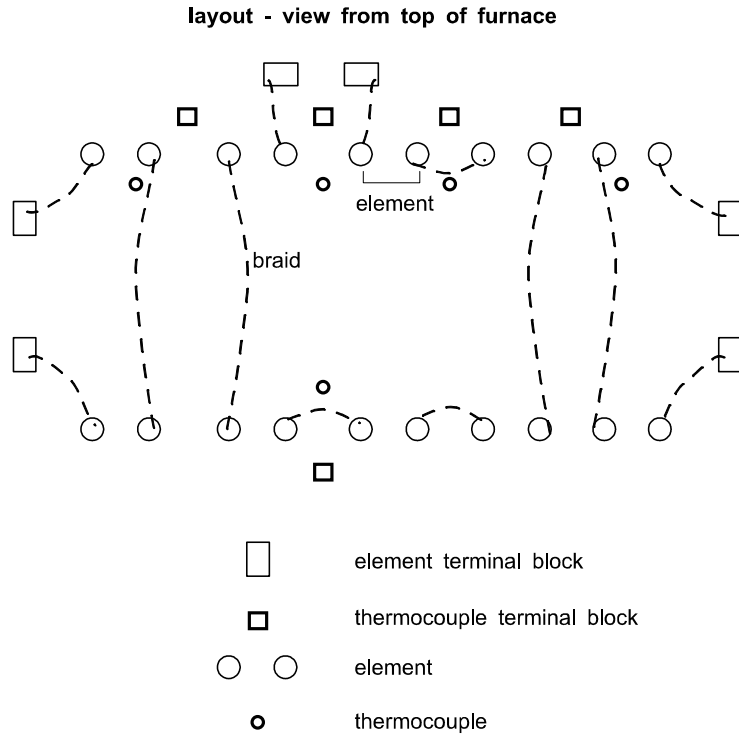

*Example: CTF 17/300*

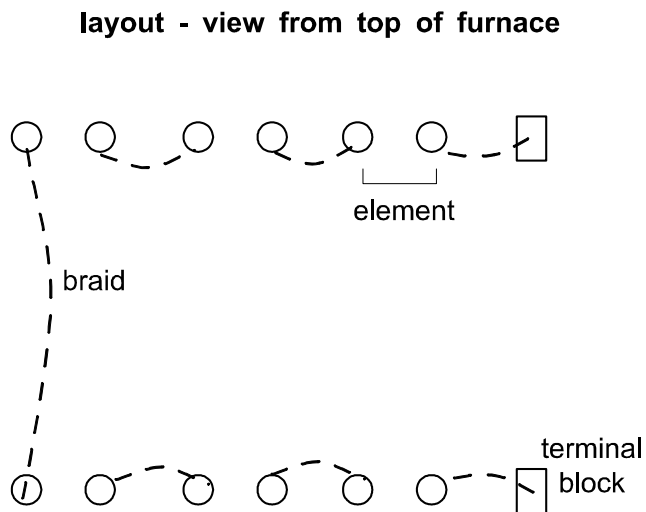

Note: /300 models have 6 elements in series  
 CTF /600 single phase models have 10 elements in series  
 CTF /600 3-phase models have 4 els in S – 2 els in S – 4 els in S  
 TZF /600 models have 2 els ins S – 6 els in S – 2 els in S

**6.0**

**FAULT ANALYSIS****A. Furnace Does Not Heat Up**

- |  |  |   |
|--|--|---|
| 1. The <b>HEAT</b> light is <b>ON</b>  | → An ohm meter applied to the element circuit shows an open circuit          | → A heating element has failed  |
| 2. The <b>HEAT</b> light is <b>OFF</b> | → The controller shows a <b>very high temperature</b> or a code such as S.br | → The thermocouple has broken or has a wiring fault   |
|  | → The controller shows a <b>low temperature</b>                              | → The door switch may be faulty or need adjustment<br>→ The thyristor fuse may have blown<br>→ The power thyristor could be failing to switch on due to internal failure, faulty wiring from the controller, or faulty controller |
|  | → There are no lights glowing on the controller                              | → The controller may be faulty or not receiving a supply due to a faulty switch or a wiring fault   |
|  |  | → The <b>SUPPLY</b> light is <b>ON</b>  |
|  |  | → The <b>SUPPLY</b> light is <b>OFF</b>   |
|  |  | → Check the supply fuses and any fuses in the furnace control compartment   |

**B. Furnace Overheats**

- |  |   |   |
|--|---|---|
| 1. The <b>HEAT</b> light goes <b>OFF</b> with the instrument switch  | → The controller shows a <b>very high temperature</b> | → The controller is faulty  |
|  | → The controller shows a <b>low temperature</b>       | → The thermocouple may have been shorted out or may have been moved out of the furnace<br>→ The thermocouple may be mounted the wrong way round<br>→ The controller may be faulty |
| 2. The <b>HEAT</b> light <b>does not go off</b> with the instrument switch and the fault persists when a 2A control fuse is removed from its fuse-holder | → The power thyristor has failed "ON"                 | → Check for an accidental wiring fault which could have overloaded the thyristor.<br><i>Isolate the furnace if this fault persists.</i>   |

**7.0**

**CIRCUIT DIAGRAM**

**7.1 Example - CTF 17/300 single phase**

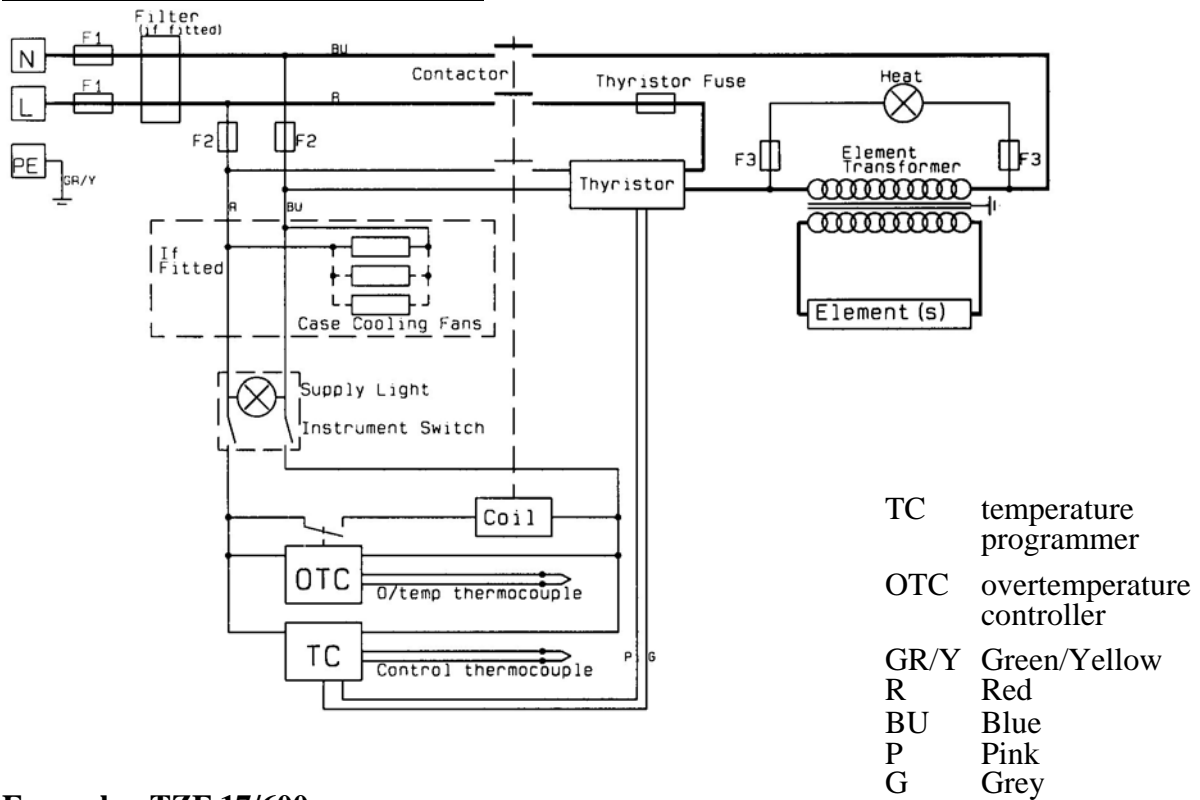

**7.2 Example - TZF 17/600**

Three-phase + Neutral, back-to-back thermocouples

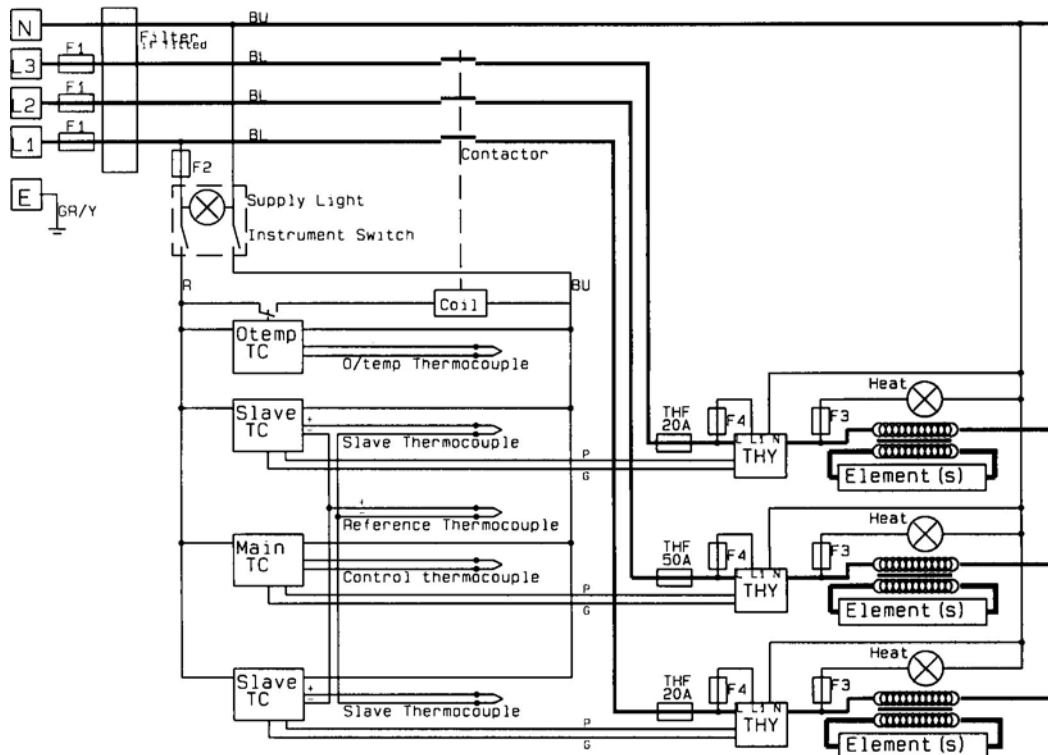

**8.0**

## FUSES & POWER CONTROL

### 8.1 Fuses

F1 & F2 - see the example circuit diagram.

F1 Supply Fuses:

Supply fuses are not fitted internally unless the furnace is also fitted with a supply cable; when fitted they are of GEC Safeclip of the type shown.

Customers should fuse at the rating shown.

F2 Control Fuses: 2 Amp type F 30mm x 6mm

*Thyristor Fuse:* Ferraz Protistor of the rating shown. Note that, unlike most fuses, protistor fuses are correctly rated at a higher current than the thyristor they are protecting.

### 8.2 Power Control

The setting for the power limit parameter in the controller ( $\overline{PPh}$ ) should be 100% for all models.

The thyristor stacks are set to the secondary (element) maximum currents given in the table.

Model	Phases	volts	supply fuse rating	type	thyristor fuse rating	Current limit (element circuit)
CTF 17/300	1-phase	220-240	30-32A	NS32	50A	90A
CTF 17/600	1-phase	220-240	50A	ES50	63A	90A
CTF 17/600	3-phase	380/220-415/240	25A	NS25	2 x 30A + 1 x 20A	134A
CTF 17/600	3-phase delta	220-240	25A	NS25	2 x 30A + 1 x 20A	134A
TZF 17/600	1-phase	220-240	50A	ES50	2 x 20A + 1 x 50A	90A
TZF 17/600	3-phase	380/220-415/240	30-32A	NS32	2 x 20A + 1 x 50A	90A
TZF 17/600	3-phase delta	220-240	40A	ES40	2 x 20A + 1 x 50A	90A
CTF 18/300	1-phase	220-240	30-32A	NS32	50A	134A
CTF 18/600	1-phase	220-240	50A	ES50	63A	134A
CTF 18/600	3-phase	380/220-415/240	25A	NS25	2 x 30A + 1 x 20A	134A
CTF 18/600	3-phase delta	220-240	40A	ES40	2 x 30A + 1 x 20A	134A
TZF 18/600	1-phase	220-240	63A	ES63	2 x 20A + 1 x 50A	90A
TZF 18/600	3-phase	380/220-415/240	32A	NS32	2 x 20A + 1 x 50A	90A
TZF 18/600	3-phase delta	220-240	63A	ES63	2 x 20A + 1 x 50A	90A

## 9.0 SPECIFICATIONS

Carbolite reserves the right to change specifications without notice.

### 9.1 Models Covered by this Manual

MODEL	Max. Temp. (°C)	Max. Power (kW)	Work Tube Diameter (max) (mm)	Work Tube Length (min) (mm)	Heated Length (mm)	Net Weight (kg)
<i>Tube Furnaces heated by Molybdenum Disilicide elements.</i>						
CTF 17/300	1700°C	6	75	900	300	176
CTF 17/600	1700°C	9	75	1200	600	220
TZF 17/600	1700°C	9	75	1200	600	280
CTF 18/300	1800°C	6	75	900	300	176
CTF 18/600	1800°C	10	75	1200	600	
TZF 18/600	1800°C	10	75	1200	600	

### 9.2 Environment

The furnaces contain electrical parts and should be stored and used in indoor conditions as follows:

temperature: 5°C - 40°C

relative humidity: maximum 80% up to 31°C decreasing linearly to 50% at 40°C

The products covered in this manual are only a small part of the wide range of ovens, chamber furnaces and tube furnaces manufactured by Carbolite for laboratory and industrial use. For further details of our standard or custom built products please contact us at the address below, or ask your nearest stockist.

*For preventive maintenance, repair and calibration of all Furnace and Oven products, please contact:*

#### **Thermal Engineering Services**

**Telephone:** UK: 0845 3308035 Int: +44 1433 623335  
**Fax:** UK: 0845 3308036 Int: +44 1433 623336  
**Email:** service@thermalservice.com



MF32-3.20

22/02/08

1800 Tube

Carbolite, Parsons Lane, Hope, Hope Valley, S33 6RB, England.

**Telephone:** (01433) 620011

Int: +44 1433 620011

**Facsimile:** (01433) 621198

Int: +44 1433 621198

**E-mail:** info@carbolite.com