



Installation, Operation & Maintenance Instructions

1700-1800°C Chamber Furnaces

HTF 17 & HTF 18

This manual is for the guidance of operators of the above Carbolite products and should be read before the furnace is connected to the electricity supply.

Contents

Section		Page
1.0	Introduction	3
2.0	Installation	4
3.0	Operation	6
4.0	Maintenance	9
5.0	Repairs, Replacements & Adjustments	11
6.0	Fault Analysis	16
7.0	Circuit Diagram	17
8.0	Fuses & Power Control	19
9.0	Specifications	22

Manuals for the furnace controller and overtemperature controller are supplied separately.

Please read the controller manuals before operating the furnace.

1.0 INTRODUCTION

1.1 HTF Range

This manual applies to the 1700-1800°C furnace models HTF 17/5, HTF 17/10, HTF 18/4 and HTF 18/8, from 2003 onwards. These are bench mounted units sharing a common case size and design principles.

1.2 Switches and Lights



Supply Light: when the furnace is connected to the electrical supply the light in the adjacent switch glows

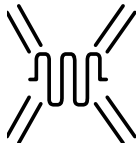

Heat Light: the adjacent light glows or flashes to indicate that power is being supplied to the elements

1.3 Warning Symbols

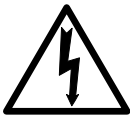

DANGER of electrical shock– read any warning printed by this symbol.



DANGER – hot surface. Read any warning printed by this symbol.
WARNING: all surfaces of a furnace may be hot.



DANGER – read any warning printed by this symbol.

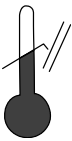

FAULT – read any information printed by this symbol.

1.4 General Warnings



READ this manual through before installing or operating the furnace.

COMPETENT people only should be permitted to install, maintain and operate the furnace. Installation and maintenance should be done by a qualified electrician, or by someone with a thorough understanding of electrical components and safety. Operating should be done by a person who has read this manual and is aware of and understands the safety issues in using high temperature electrically heated equipment.

2.0 **INSTALLATION**

2.1 **Unpacking & Handling**



When unpacking or moving the furnace always lift it by its base. Never lift it by the door or the side panel. The furnace contains a transformer and is heavy: use two or more people to carry it.

Remove any packing material from the door gear and from inside the furnace chamber. Close the door with care to prevent any damage to insulation surfaces.

2.2 **Siting & Setting Up**

Place the furnace in a well ventilated room, away from other sources of heat, and on a surface which is resistant to accidental spillage of hot materials. Do not mount the furnace on an inflammable surface. Do not mount the furnace where radiated heat from an open door could cause damage.

Ensure that there is at least 75mm of free space around the furnace, and preferably 1.5m above. Do not obstruct any of the vents in the case, or leave objects of any kind on the top surface. In particular, the cooling fans in the case must not be obstructed.

If the furnace is to be used in a process which could liberate hazardous gases, then it should be installed together with a suitable fume extraction system. A direct connection to the furnace chimney should not be made.

Ensure that the furnace is placed in such a way that it can be quickly switched off or disconnected from the electrical supply.

2.3 **Fitting the Heating Elements**



Wear eye protection when handling the heating elements. See the warning in section 5.8.

The Molybdenum Disilicide elements are EXCEPTIONALLY FRAGILE and are packed separately, together with other items as shown in the list.

<u>separately packed items</u>	<u>1700°C models</u>	<u>1800°C models</u>
Elements	4	5
Element clamps	8	10
Element clips	8	10
Braids	1 set of 5	1 set of 6
Separators/Blocks	4	5
Chimney unit	1	1

The installation of these elements is described in section 5.8. Connect the aluminium braids securely as indicated in the installation instructions.

2.4 Electrical Connections



Connection must be made by a competent person. A qualified electrician is recommended.

These models are designed only for single phase electrical supplies, or for two live phases and neutral of a 3-phase supply. The furnace must be connected only to the type and voltage of supply for which it was ordered, though some changes may be made as explained in section 2.5.

Check that the supply voltage is compatible with the voltage on the label, and that the current capacity is sufficient for the amperage on the label, before connection to the supply. A table of the most common ratings is given in section 8.1 of this manual.

Normally a supply cable is not fitted, and connection is to be made to terminal blocks accessed by removal of the left-hand end side cover (see section 5.3). The supply cable must be properly connected and fitted with an appropriate strain relief at the entry to the case.

The supply cable should be wired to an isolator or fitted with a line plug. The isolator must be within easy reach of the operator, or the line plug must be easily removable and on a lead not exceeding 3m length. The line plug must allow the protective earth (ground) to be connected before the supply conductors and to be disconnected after them. The supply point must be marked as the disconnecting device for the furnace.

The supply **MUST** incorporate an earth (ground).

CONNECTION DETAILS			<i>supply type</i>	
Supply	Terminal label	Cable colour	<i>Live-Neutral</i>	<i>Reversible or Live-Live</i>
<i>1-phase</i>	L	Brown	to live	to either power conductor
	N	Blue	to neutral	to the other power conductor
	PE	Green/Yellow	to earth (ground)	to earth (ground)
<i>2-phase</i>	L1	Black	to phase 1	
	L2	Black	to phase 2	
	N	Light Blue	to neutral	
	PE	Green/Yellow	to earth (ground)	

2.5 Voltage Differences

Each model is manufactured in one of the following voltage range varieties:

- 208V
- 220 to 240V
- 380 to 415V (not HTF 17/5 or HTF 18/4)

It is not possible to alter a furnace between the 380-415 range and either of the other ranges: there are too many component differences.

It is possible to alter a furnace between 208 and 220-240, provided the thyristor unit is replaced. A transformer tapping must also be altered. See sections 5.4 and 5.10.

It is possible to alter the voltage within one of the ranges above, by reconnecting the incoming cable to the transformer to the appropriate primary tapping. The tappings are 208-220-230-240V, or 380-400-415V, and are labelled on the primary side of the transformer – see section 5.10. It is also necessary to adjust the setting of the thyristor stack: see section 5.4.

Examples:

- to alter a furnace made for a 240V supply to 208V: replace the thyristor stack, move a cable to the 208V transformer tapping, and adjust the thyristor stack.
- to change from a supply of 220V to 230V: move a cable to the 230V tapping, and adjust the thyristor stack.

3.0 **OPERATION**

The instructions for operating the temperature controller are given in a separate manual. If the furnace is fitted with a time switch, see also the supplementary manual MS03. If cascade control is fitted, see the supplementary manual MS07.

3.1 **Operating Cycle**

The furnace is fitted with a combined Supply light and Instrument switch. The light is on whenever the furnace is connected to the electrical supply. The switch cuts off power to the controllers and contactor.

Connect the furnace to the electrical supply. The Supply light should glow and the cooling fans operate.

Operate the instrument switch to activate the temperature controller. The controller becomes illuminated and goes through a short test cycle.

Close the furnace door and adjust the temperature controller – see the controller manual.

Set the overtemperature controller to a temperature a little (say 15°C) above the maximum setpoint or program temperature.

Unless a time switch is fitted and is off, the furnace starts to heat up. The Heat light glows brightly at first, more dimly as the furnace temperature approaches a program setpoint.

If the overtemperature trip operates then an indicator or message in the overtemperature controller flashes, and the heating elements are isolated. Find and correct the cause before resetting the overtemperature controller according to the instructions supplied.

To switch the furnace off, set the Instrument switch to off. The case cooling fans remain on and the chamber can be unloaded.

Do not disconnect the furnace from the electrical supply until it cools to below 300°C; ensure that the cooling fans are still running if the furnace is above that temperature.

If the furnace is to be left off unattended and has cooled down, isolate it from the electrical supply.

3.2 **Operator Safety - Electrical**

The furnace incorporates a safety switch which interrupts the heating element circuit when the door is opened. This prevents the user touching a live heating element, but also prevents the furnace from heating up if the door is left open.



The operation of this switch should be checked periodically – see section 4.1.2.

3.3 **Operator Safety - Heat**



Furnace surfaces

The case surface gets hot; even though this is within permitted limits, operators should at all times take care. The chimney gets especially hot – do not touch it.



Opening the furnace door

Wear heat-resistant clothing, including appropriate hand and face protection (see also the warning about eye protection in section 5.8). Opening the door when hot could damage clothing, or even set it alight, because of high levels of radiated heat. Do not keep any inflammable objects near the furnace, nor objects which could be damaged by radiated heat.

See also section 3.5.

3.4 **Loading the Furnace**

When heating large objects, in particular poor conductors, avoid shielding the thermocouple from the heating elements. Also ensure that nothing is within 15mm of the elements.

The thermocouple is intended to sense the temperature near the heating element, but if a large object is placed in the chamber it may record the average temperature of the object and the elements, which can lead to overheating of the elements. Allow large objects to gain heat at a lower temperature and then reset the controller to a temperature close to the desired maximum.

Take care that nothing hits the elements when loading or unloading.

3.5 Opening the Door



Take great care when loading or unloading the furnace chamber. See section 3.3. Before you remove a hot object from the furnace make sure you have a safe place to put it down.

Do not open the door at high temperatures. If possible, do not open it above 200°C. If it is necessary to load or unload work at elevated temperatures, keep the door open for as short a period as possible. The insulation cools quickly and may crack through thermal shock.

The heating elements and the insulation are very susceptible to mechanical shock. At all times operate the door gently to avoid mechanical shock.

Opening the door when the furnace is very hot can cause hot air to be sucked by the case cooling fans towards the thermal cutout and activate it (see section 3.13). Avoid excessive door opening and shut it as soon as possible.

3.6 Insulation Cracking

In these furnaces the insulation material is susceptible to surface cracking arising from high temperature cycling; this is a normal occurrence and such cracking is not detrimental to the performance of the furnace.

3.7 Atmospheres & Corrosive Materials

In oxidising atmospheres, metal oxides react with the silica layer on the surface of the elements and may lead to premature failure. Protect the elements from splashes of molten metal and dust when charging the furnace, and from fumes developed when melting, especially from fluxes. Also avoid compounds with a high alkali content.

The furnace is designed for use up to its maximum temperature in oxidising atmospheres, but can also be operated successfully in neutral or carburising atmospheres. It may be used with nitrogen, argon or helium atmospheres to 1600°C. Reducing atmospheres are not recommended. Sulphur dioxide in normal concentrations is not harmful, but chlorine, and more so fluorine, strongly attack even oxidised elements and should be avoided.

The furnace is not recommended for burning off carbonaceous materials. Other Carbolite furnaces are available for this application.

When an optional gas inlet is fitted there is a label near the inlet saying "INERT GAS ONLY". In practice *inert* or *oxidising* gases may be used, but not combustible or toxic gases. The furnaces are not gas tight, so it should be understood that gas usage may be high, and that the chamber is likely always to contain some air. Residual oxygen levels of at least 1% are to be expected.

The hearth can be protected from abrasion, by the provision of a secondary plate. This consumable item can either be in light weight ceramic fibre or in dense, hard-wearing alumina refractory.

3.8 Pesting

The furnace is fitted with Molybdenum Disilicide elements and is therefore susceptible to pesting. Pesting can be seen as a yellowish crystal growth on the surface of the element. It occurs when the element surface temperature is around 450°C and is caused by the air oxidising with the Molybdenum in the element compound. Under normal operating conditions (above 800°C) pesting is not a problem and can often be seen occurring naturally on the element terminals.

Running the furnace for prolonged periods at temperatures below 600°C will cause pesting to occur on the element surface and will eventually damage the elements.

Heating on a slow ramp rate or dwelling at temperatures below 600°C for short periods will not cause a problem providing the furnace is run above 1400°C at regular intervals to recondition the element surfaces.

Large amounts of peeling occurring on the element terminals must be removed in accordance with good health and safety practices.

3.9 Explosive Materials

The furnace must not be used to heat materials which could explode, or which could emit gases that could form explosive mixtures.

3.10 Note on Temperature Control

The furnace is designed for rapid heating and cooling applications. The programmer enables the furnace to heat or cool at slower rates as desired, and variable "hold" (dwell) periods can be programmed as required.

The programmer is used in conjunction with a phase angle thyristor control unit, which incorporates a current limit potentiometer preset by Carbolite, but which will require adjustment in the event of change of supply voltage (see section 5.4).

The elements are connected in series across the low voltage output of a transformer housed in the furnace case. Molybdenum disilicide elements do not age, so if an element fails it is not necessary to replace the complete set.

3.11 Thermocouples - aging

The output from 1700-1800°C thermocouples when used regularly at temperatures greater than 1650°C will deteriorate and decrease with age faster than if used at temperatures below 1650°C; this will cause the furnace to run at a higher temperature than indicated.

Customers are advised periodically to check the thermocouple output, either by a calibration test, or by comparing the output with a new reference thermocouple. Any such comparison must be done at a high temperature, say 1400°C or more.



Failure to check the thermocouple regularly may result in overheating of the work and the furnace, with consequent damage to both.

3.12 Thermocouples – low temperatures

The thermocouples fitted to these models give very low outputs below about 600°C, and do not give accurate readings at low temperatures. They may show a negative temperature when the furnace is started from cold.

The furnaces are designed for operation over 800°C; they may be run below this temperature, but accurate temperature measurement and stability is not assured.

3.13 Thermal Cutouts

There is a thermal cutout on the interior case surface at the centre top near the chimney. In the event of fan failure or any other reason for case overheating, power to the heating elements is cut.



To reset the thermal cutout, first isolate the furnace from the electrical supply. Remove the top panel and press upwards the button on the cutout device. TAKE CARE – the chimney may be hot.

There is a further thermal cutout in the element circuit transformer which cuts power if the transformer core overheats. This is self-resetting.



If either thermal cutout is activated, then a fault light on the control panel is illuminated.

3.14 General Operating Advice

Heating element life is shortened by use at temperatures close to maximum, so avoid leaving the furnace at high temperature when not required. The furnace can be cycled between room

temperature and maximum without a detrimental effect on element life. The maximum temperature is shown on the rating label and on the back page of this manual.

4.0 MAINTENANCE

4.1 Routine Maintenance

Preventive rather than reactive maintenance is to be preferred. The type and frequency depends on furnace use: the following are recommended.

4.1.1 Cleaning

The furnace outer surface may be cleaned with a damp cloth. Do not allow water to enter the interior of the case or chamber. Do not clean with organic solvents.

4.1.2 Safety Switch



The door switch operation mentioned in 3.2 should be checked periodically to ensure that heating elements are isolated when the door is opened. In normal conditions the safety arrangement should outlast the furnace, but it could be affected by rough handling, a corrosive environment or work materials, or exceptional frequency of use. The frequency of checking depends on furnace use: if in doubt, make the check.

A qualified electrician should check that the supply to the heating elements is cut, with and without power being on, when the door is open partially and fully; it is important that isolation is not just marginally achieved. The check should be made on the element ends or braids after removal of the case top. Note that both live supply wires of a 2-phase supply, and both live and neutral of a 1-phase supply, should be isolated when the door is opened.

4.1.3 Other Electrical Components

Regular visual or electrical checks should be made on the condition of the supply cable, and all internal fuses and visible internal cables should be inspected periodically.

4.1.4 Element Glaze

Depending on use the heating elements may lose their glaze and gain a rough appearance. They should be checked from time to time. If the glaze has gone, it may be restored by heating the furnace up to 1500°C without load, for 2 hours or so.

4.2 Calibration

After prolonged use the controller and/or thermocouple could require recalibration; see the warning about 1700-1800°C thermocouples in section 3.11. This would be important for processes which require accurate temperature readings or which use the furnace close to its maximum temperature. A quick check using an independent thermocouple and temperature indicator should be made from time to time to determine whether full calibration is required. Carbolite can supply these items.

Depending on the controller, the controller manual may contain calibration instructions.

4.3 After Sales Service

Carbolite's service division (Thermal Engineering Services) has a team of Service Engineers capable of repair, calibration and preventive maintenance of furnace and oven products at our customers' premises throughout the world. We also sell spares by mail order. A telephone call or fax often enables a fault to be diagnosed and the necessary spare part despatched.

Each furnace has its own record card at Carbolite. In all correspondence please quote the serial number, model type and voltage given on the rating label of the furnace. The serial number and model type are also given on the front of this booklet when supplied with a furnace.

To contact Thermal Engineering Services or Carbolite see the back page of this manual.

4.4 Recommended Spares Kits

Carbolite can supply individual spares, or a kit of the items most likely to be required. Ordering a kit in advance can save time in the event of a breakdown. Each kit comprises one thermocouple,

one sheath, one power thyristor, one door insulation piece, and a set of elements, clips and braids. It is advisable also to obtain element clamps and insulators (not included in kit). Individual spares are also available.

When ordering spares please quote the model details as requested above.

4.5 Power Adjustment (Controller)

The furnace controller incorporates a power limit parameter $\overline{P}H$ which is usually inaccessible to the operator.

Occasionally the power limit is set to zero to permit demonstration of the controls without the heating elements taking power. In this case the power limit is accessible to the operator and may be reset to its standard value of 100.

4.6 Power Adjustment (Thyristor)

The current-limiting thyristor stacks which control power to the elements are fitted with an adjustable resistor which is factory set to limit the maximum current supplied. In the event of a change of supply voltage, or the fitting of a new thyristor, re-adjustment is required. See section 5.4.

4.7 Low Voltage Compensation

If the supply voltage proves to be routinely below the nominal figure for which the furnace has been set up, there is a “+2%” position on the transformer primary side which may be used instead of the standard position. See section 5.10.

5.0 REPAIRS, REPLACEMENTS & ADJUSTMENTS

5.1 Safety Warning – Disconnection from Supply

Always ensure that the furnace is disconnected from the electrical supply before repair work is carried out. *Note: the Instrument switch on the front panel does not isolate the furnace from the supply.*

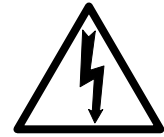

5.2 Safety Warning - Refractory Fibrous Insulation

This furnace contains refractory fibres in its thermal insulation. These materials may be in the form of fibre blanket or felt, vacuum formed board or shapes, mineral wool slab or loose fill fibre.

Normal use of the furnace does not result in any significant level of airborne dust from these materials, but much higher levels may be encountered during maintenance or repair.



Whilst there is no evidence of any long term health hazards, we strongly recommend that safety precautions are taken whenever the materials are handled.

Exposure to dust from fibre which has been used at high temperatures may cause respiratory disease.

When handling fibre always use an approved mask, eye protection, gloves and long sleeved clothing.

Avoid breaking up waste material. Dispose of waste fibre in sealed containers.

After handling rinse exposed skin with water before washing gently with soap (not detergent). Wash work clothing separately.

Before commencing any major repairs we recommend reference to the European Ceramic Fibre Industry Association Bulletin No. 11 and the UK Health and Safety Executive Guidance Note EH46.

We can provide further information on request. Alternatively our service division can quote for any repairs to be carried out at your premises or ours.

5.3 Side Panel Removal



Except where explicitly stated, always disconnect the electrical supply before removing the side panel.

Remove the panel by slackening the four fixing screws (behind plastic caps) at the left-hand end of the furnace; do not remove the screws. Lift the panel about 15mm and then pull off to the side.

5.4 Thyristor Replacement and Adjustment

Replacement

To replace the thyristor unit, isolate the furnace from the electrical supply and remove the left-hand side cover (5.3). Make a note of all wiring to the thyristor, and disconnect it. Replace the unit and connect the wiring again.

Note that the thyristor unit requires replacement if changing from or to a 208V supply.

If the thyristor unit has been replaced because of a change of voltage, then the correct transformer tapping should also be set – see section 5.10.

Adjustment

After any thyristor unit replacement, or any change of voltage or transformer tapping, the potentiometer on the thyristor must be adjusted to give the correct element current. This should be done by a qualified person, as there are dangerous voltages inside the control compartment. It also requires a calibrated non-intrusive clip-on ammeter.

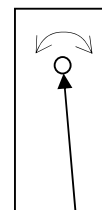

potentiometer

Before connecting the electrical supply, turn the potentiometer on the thyristor fully to the left (anti-clockwise). This sets the output current of the thyristor to ‘off’.

Connect the electrical supply with the side cover off. Take care! Set the furnace temperature to maximum. Allow the furnace to start heating up.

Measure the current through the element circuit. This is done with the clip-on meter around one pair of thick cables on the left-hand side of the transformer (as seen when facing the control side of the furnace).

Adjust the potentiometer on the face of the thyristor unit. Adjust it slowly to the right (clockwise) to increase the current, pausing to allow the time for response at the meter. Keep adjusting to obtain an ammeter reading of between (149 to 150 A for HTF 17) or (139 to 140A for HTF 18). This adjustment should be set up within the first 5 minutes of heat up from ambient and should finally be checked when the furnace temperature is approximately 100°C below its maximum temperature. Make further adjustment if necessary at this temperature.

Disconnect the electrical supply to ensure safe replacement of the side panel. See Section 3.1 before disconnecting the power supply.

5.5 Temperature Controller Replacement

2132, 2416, 2408 etc. Ease apart the two lugs at the side; grip the instrument and withdraw it from its sleeve; push in the replacement.

5.6 Fuse Replacement

Access to internal fuses is by removal of the furnace side cover (see 5.3). See section 8.1 for details of fuses fitted.

5.7 Thermocouple Replacement

Disconnect the furnace from the electrical supply, and remove the furnace back panel (1700 models) or top cover (1800 models).

Make a note of the thermocouple connections. The negative leg of the thermocouple is marked blue. The “compensating” cable for 1700 & 1800°C thermocouples is plain copper.

Disconnect the thermocouple from its terminal block.

Undo the screw to release the thermocouple sheath; withdraw the sheath, and shake out any fragments of thermocouple.

Re-assemble with a new thermocouple observing the colour coding, ensuring that the thermocouple is not twisted as it is being inserted and that the metal tag is bent back, or the screw inserted, to grip the sheath.

5.8 Element Installation & Replacement

Safety Warning:

Molybdenum disilicide elements form a glazed surface when heated. Internal stresses can form through heating and cooling which render the glaze fragile. The glaze can sometimes splinter into a shower of sharp particles when handled. Always wear eye protection when handling the elements.



Handle the heating elements with extreme care as they are **very fragile**. Also, avoid touching the heating surface (the thin part of the element), as the material is susceptible to corrosive damage from skin contact.

Initial Installation:

The elements, clips and braids are packed separately. Handle them carefully while unpacking.

Fit the insulation blocks to the elements. Locate the clamps over the elements, and tighten carefully. The length of element above the fixing clamps should be as follows:

1700° models: 42mm

1800°C models: 45mm

Lower the elements into position, and connect the braids according to the scheme shown below, using the clip tool provided. The braids must be held tightly to the element as the clips are fitted: **good contact is essential**; poor contact can lead to sparking and destruction of the top of the element.

Ensure that the elements are correctly placed: the thin part of the element, and the tapered section, should ideally be entirely within the heating chamber; the element should not touch the bottom of the chamber.

Important -There should be a minimum clearance of 10mm below the bottom of the element, and a minimum clearance of 15mm from the sides of the chamber. The elements should be parallel with the sidewalls.

Replacements:

Read the section above on initial installation.

Remove the aluminium braids and clips using the clip tool provided with the furnace. Lift out the old elements and the insulation blocks: handle the insulation pieces with care as they are fragile. Carefully loosed and remove the clamps.

Prepare and install the new elements as explained above.

Heat up the furnace to a moderate temperature and ensure that the furnace is controlling properly, in case the previous element failure resulted from a fault in the control system.

After installing new elements run the furnace at 1500°C for an hour. This creates a protective glaze on the element surface.

Element Fitting Layout

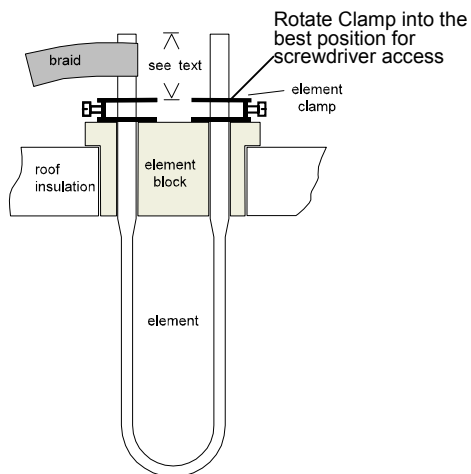

Use of Clip Tool

The tool comprises two levers

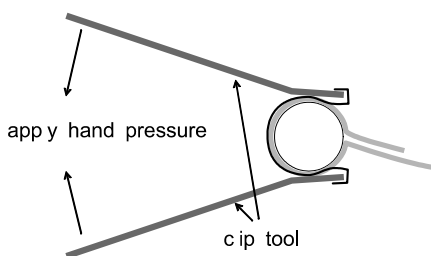

Element Connections – 4 Elements

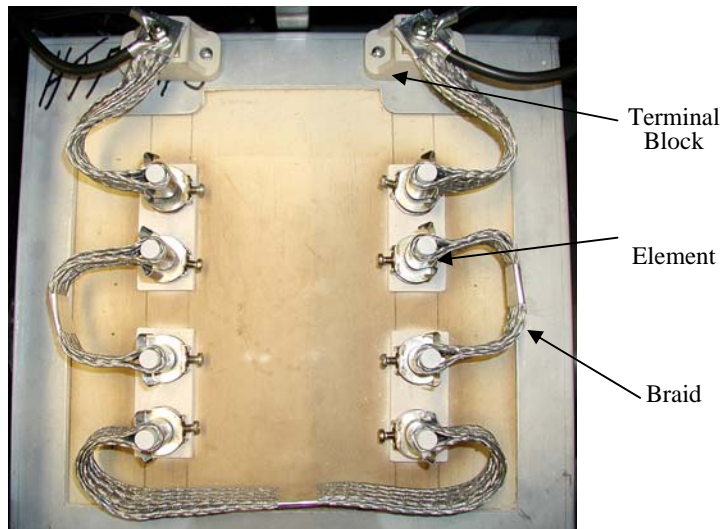

Element Connections – 5 Elements

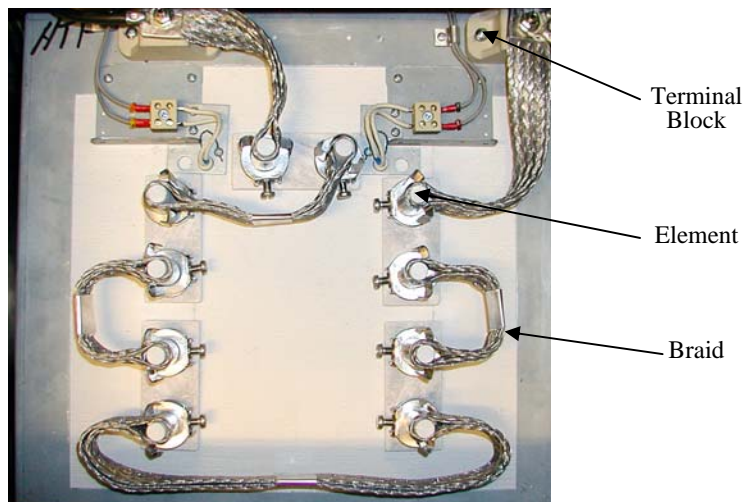

5.9 Insulation Replacement



Before undertaking any insulation replacement, see section 5.2.

After any replacement of insulation material, run the furnace at 1500°C to burn off volatile matter. Do this in a well ventilated area. Try to ensure there is some chamber ventilation, but not too much as this could result in cracked insulation.

5.10 Transformer Tappings

A change of transformer tapping is required if the supply voltage differs from the present setting.

To access the transformer tappings first disconnect the furnace from the electrical supply; then remove the left-hand side cover (see 5.3). Positions below are given from a viewing position at the left end of the furnace.

On the left side are the secondary tappings, which should not require change, but can be checked against the following data:

HTF 17/5 – 27V
 HTF 17/10 – 38V
 HTF 18/4 – 31.1
 HTF 18/8 – 43.8

On the right side is a terminal strip with the following connections (208 to 240V version shown).

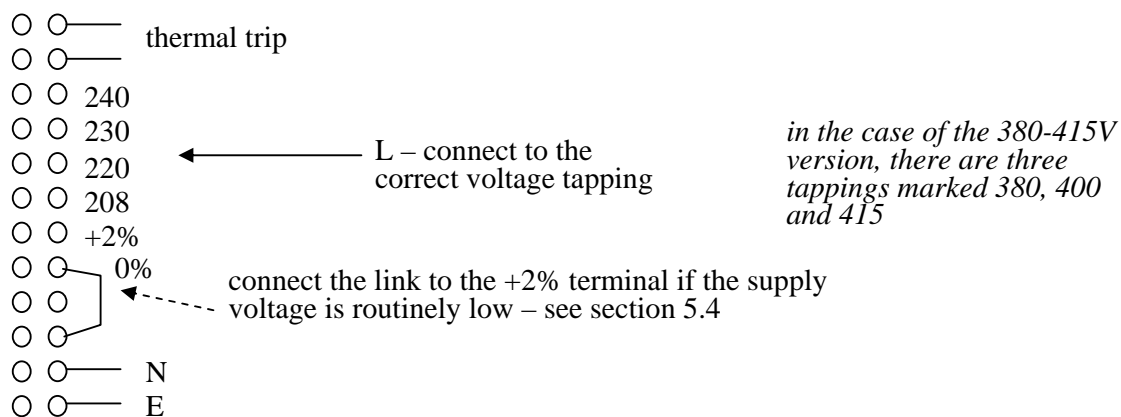

The thermal trip connection forms part of the circuit to the contactor coil.

The L and N connection may alternatively be L1 and L2 for a live-to-live supply. The L side should be connected to the correct tapping to match the supply voltage.

The link wire should be in position as shown unless the supply voltage is always low, in which case there is the option of moving one end to the +2% terminal.

Important – Changing the transformer primary tapping (including the +2%) requires adjustment of the thyristor current – see section 5.4

The terminal between the link connections is not used.

5.11 Fuses

To access fuses disconnect the furnace from the electrical supply and remove the left side cover. View the compartment from the left hand side of the furnace.

The thyristor fuse, which protects the thyristor unit, is located to the left of that unit.

If supply fuses are fitted they are to the left side of the compartment. If the incoming supply cables go directly to terminal blocks, then there are no internal supply fuses (F1, section 8.1).

The control circuit fuses (F2) are near the EMC filter unit on the left side of the compartment.

6.0 FAULT ANALYSIS

A. Furnace Does Not Heat Up

- | | | |
|--|--|---|
| 1. The HEAT light is ON | → An ohm meter applied to the element circuit shows an open circuit | → A heating element has failed |
| 2. The HEAT light is OFF | The controller shows a very high temperature or a code such as S.br | → The thermocouple has broken or has a wiring fault |
| | The controller shows a low temperature | → The door switch may be faulty or need adjustment
→ The thyristor fuse may have blown
→ The power thyristor could be failing to switch on due to internal failure, faulty wiring from the controller, or faulty controller |
| | The fault light on the control panel is on | → The thermal cutout on the case or in the transformer has activated |
| | There are no lights glowing on the controller | → The SUPPLY light is ON → The controller may be faulty or not receiving a supply due to a faulty switch or a wiring fault
→ The SUPPLY light is OFF → Check the supply fuses and any fuses in the furnace control compartment |

B. Furnace Overheats

- | | | |
|--|---|---|
| 1. The HEAT light goes OFF with the instrument switch | → The controller shows a very high temperature | → The controller is faulty |
| | → The controller shows a low temperature | → The thermocouple may have been shorted out or may have been moved out of the furnace
→ The thermocouple may be mounted the wrong way round
→ The controller may be faulty |
| 2. The HEAT light does not go off with the instrument switch and the fault persists when a 2A control fuse is removed from its fuse-holder | → The power thyristor has failed “ON” | → Check for an accidental wiring fault which could have overloaded the thyristor.
<i>Isolate the furnace if this fault persists.</i> |

7.0 CIRCUIT DIAGRAM

7.1 Single Phase 208V, 220-240V

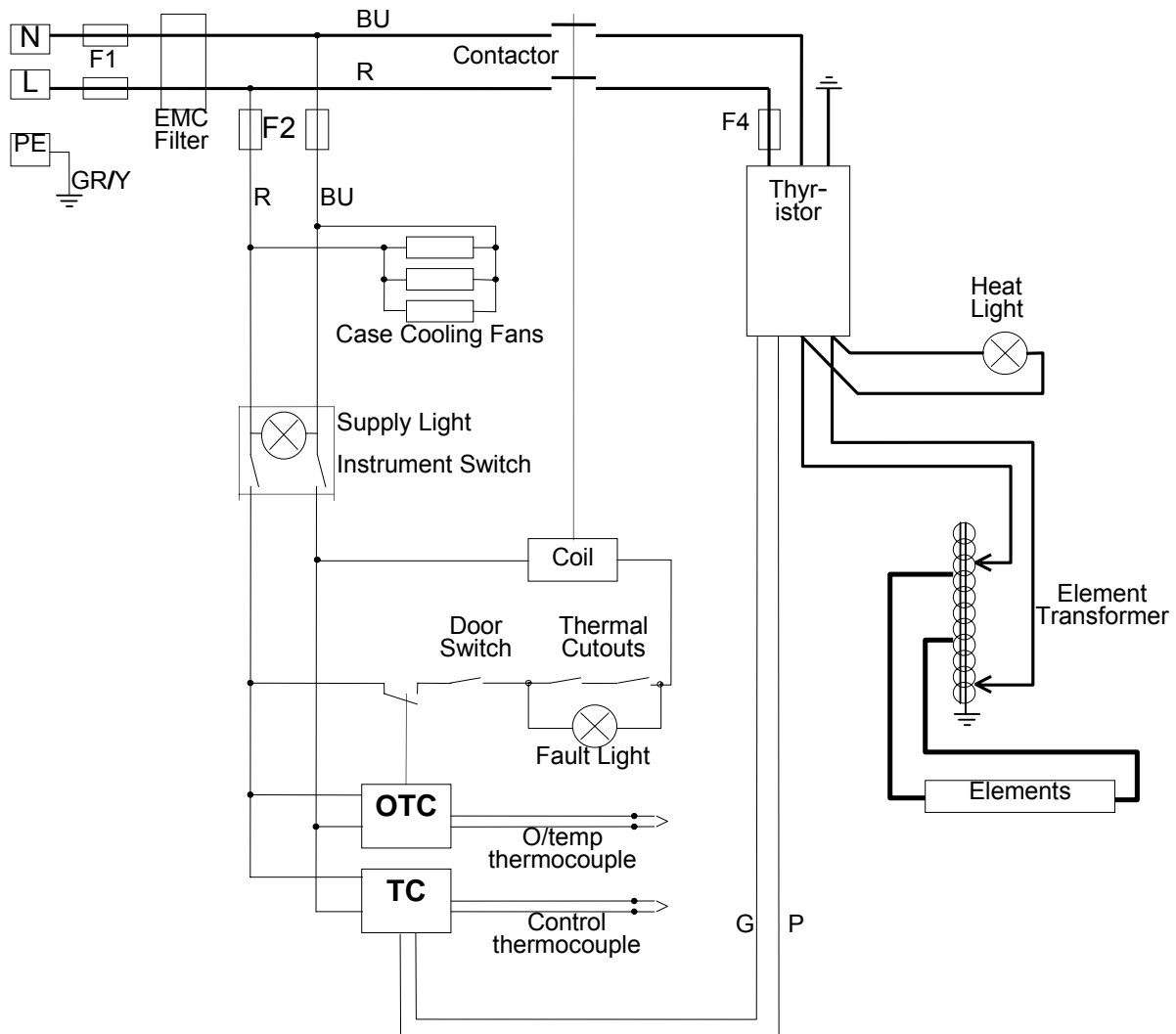

thermal cutouts:

case temperature sensor
transformer temperature sensor

TC temperature controller
OTC overtemperature controller

F1 Supply fuses (present if supply cable fitted)
F2 Auxiliary circuit fuses (2A)
F4 Thyristor protection fuse (Ferraz Protistor)

BU Blue
R Red
P Pink
G Grey
GR/Y Green & Yellow

8.0 FUSES & POWER CONTROL

8.1 Fuses

F1-F2: Refer to the circuit diagrams.

<i>F1</i>	Internal supply fuses	Fitted if a supply cable originally fitted.	Ferraz fuse of the rating shown
<i>F2</i>	Auxiliary circuit fuses		2 Amps type F 32mm x 6mm
<i>F4</i>	Thyristor Fuse		Ferraz Protistor fuse of the rating shown
	Customer fuses	Required if no supply cable fitted. Recommended if cable fitted.	See rating label for amperage; see table below for fuse rating.

The table below gives the fuse rating for the various models.

8.2 Power Control

The setting for the power limit parameter in the controller ($\overline{P.H.}$) should be 100% for all models.

The current-limiting thyristor stacks are set to the maximum element currents given in the table.

TABLE OF FUSE AND CURRENT LIMIT VALUES

Model	Phases	volts	supply fuse rating	thyristor fuse rating	current limit (element circuit) †
HTF 17/5	1-phase	208	20A	30A	150A
HTF 17/5	1-phase	220-240	20A	30A	150A
HTF 17/10	1-phase	208	30A or 32A	50A	150A
HTF 17/10	1-phase	220-240	30A or 32A	50A	150A
HTF 17/10	2-phase *	380-415	20A	30A	150A
HTF 18/4	1-phase	208	20A	30A	140A
HTF 18/4	1-phase	220-240	25A	30A	140A
HTF 18/8	1-phase	208	32A	50A	140A
HTF 18/8	1-phase	220-240	30A	50A	140A
HTF 18/8	2-phase *	380-415	16A	30A	140A

* 2-phase designs use the line-to-line voltage; neutral is used for the control circuit

† see section 4.6 – the current limit setting at low temperatures is 146A

9.0 SPECIFICATIONS

Carbolite reserves the right to change specifications without notice.

9.1 Models Covered by this Manual

MODEL	Max. Temp. (°C)	Max. Power* (kW)	Chamber Size (mm)			Approx. Capacity (l)	Max. Load (kg)	Net Weight (kg)
			H	W	D			
HTF 17/5	1700°C	4.3	158	150	225	5.3	2.5	87
HTF 17/10	1700°C	6	232	200	225	10.4	5	106
HTF 18/4	1800°C	4.6	141	140	205	4	2	92
HTF 18/8	1800°C	6.2	210	190	205	8.2	4	113

*Maximum power as measured, included ancillary components and transformer losses

9.2 Environment

The furnaces contain electrical parts and should be stored and used in indoor conditions as follows:

temperature:	5°C - 40°C
relative humidity:	maximum 80% up to 31°C decreasing linearly to 50% at 40°C
altitude:	not exceeding 2000m
electrical supply:	fluctuation not exceeding 10%
overvoltage:	category II IEC60364-4-443
pollution:	degree 2

The products covered in this manual are only a small part of the wide range of ovens, chamber furnaces and tube furnaces manufactured by Carbolite for laboratory and industrial use. For further details of our standard or custom built products please contact us at the address below, or ask your nearest stockist.

For preventive maintenance, repair and calibration of all Furnace and Oven products, please contact:

Thermal Engineering Services

Telephone: UK: 0845 3308035 Int: +44 1433 623335
Fax: UK: 0845 3308036 Int: +44 1433 623336
Email: service@thermalservice.com



MF47-3.02

20/03/08

HTF17-18

Carbolite, Parsons Lane, Hope,
Hope Valley, S33 6RB, England.

Telephone: (01433) 620011
Int: +44 1433 620011

Facsimile: (01433) 621198
Int: +44 1433 621198

E-mail: info@carbolite.com