



Installation, Operation & Maintenance Instructions

1200°C G-range Tube furnaces
Models GHA, GVA, GHC, GVC

This manual is for the guidance of operators of the above Carbolite products and should be read before the furnace is connected to the electricity supply.

CONTENTS

Section		page
1.0	Introduction	2
2.0	Installation	3
3.0	Operation	7
4.0	Maintenance	10
5.0	Repairs & Replacements	11
6.0	Fault Analysis	14
7.0	Circuit Diagrams	15
8.0	Fuses & Power Settings	18
9.0	Specifications	20

**Manuals are supplied separately for the furnace controller
(and overtemperature controller when fitted).**

Please read the controller manuals before operating the furnace.



1.0 INTRODUCTION

1.1 Products Covered

This manual contains installation and operating instructions for the single-zone tube furnaces of model types GHA and GVA, and the three-zone models GHC and GVC.

The single-zone models use one controller or programmer operating on all elements. The three-zone models use three controllers, usually linked to achieve an extended uniform temperature region, but independent controls and extended end zones are available as options.

The horizontal tube furnaces GHA and GHC are supplied with the controls in an integral base (or, to order, with the base control panel blanked off, and the controls in a separate box). A horizontal tube support kit, comprising some parts of the versatile stand, is also available.

The “versatile” models GVA and GVC models are supplied with a stand kit for horizontal, vertical or wall-mounting use, and have the controls in a separate box on a length of flexible conduit. Optionally the stand foot can be omitted, or the complete stand can be omitted.

All G-range tube furnaces have “modular” heating elements in which resistance wire is partially embedded in vacuum formed light-weight refractory fibre. The modules are 150mm long. In all standard models the two end elements (one at each end) are rated at 1170W maximum, while the other (centre) elements are rated at 780W.

All models are supplied with a pair of “tube adaptors”, which can be made to suit any work tube size up to 170mm outside diameter. Spare or replacement adaptors can be ordered.

This manual may also be issued with custom versions of the above; for example, with elements of non-standard wattage, with 2-zone or 5-zone models, or other possibilities based on the underlying design concept.

1.2 Switches and Lights



Supply Light: when the furnace is connected to the electrical supply the light in the adjacent switch glows



Heat Switch: the switch disconnects power to the heating elements; unless this switch is off there is a danger of electric shock when inserting objects into the furnace

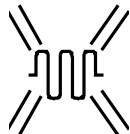

Heat Light: the adjacent light glows or flashes to indicate that power is being supplied to the elements

1.3 Warning Symbols



DANGER of electrical shock— read any warning printed by this symbol.



DANGER – hot surface. Read any warning printed by this symbol.
WARNING: all surfaces of a furnace may be hot.



DANGER – read any warning printed by this symbol.

2.0 INSTALLATION

2.1 Unpacking & Handling

When unpacking or moving the furnace always lift it by its base or by both ends of the main body. Never lift it by the end insulation or by a work tube. It will take 2 or 3 people to lift the furnace, depending on size and configuration.

Remove any packing material from inside the furnace before use.

2.2 Siting

Place the furnace in a well ventilated room, away from other sources of heat, and on a surface which is resistant to accidental spillage of hot materials. Do not mount the furnace on an inflammable surface.

Ensure that there is free space around the furnace. Do not obstruct any of the vents in the control section: they are needed to keep the controls cool.

Ensure that the furnace is placed in such a way that it can be quickly switched off or disconnected from the electrical supply - see below.

2.3 Setting Up – Horizontal Models

The horizontal models generally require no special setting up. Observe the above paragraph on siting. See section 2.5 for work tube and end adaptor considerations.

If the optional horizontal tube support kit is supplied, the rails can be fixed to the base, and the tube supports positioned at a choice of positions.

2.4 Setting Up – Versatile Models

The full stand kit may be used in several combinations.

- vertical use, bench or floor mounted: assemble the two long rails to the foot
- vertical/horizontal: as above, then add one wall bracket; the combination of foot and bracket makes the furnace body level in the horizontal position
- horizontal use only: the foot is not required; instead, a second bracket is fitted
- wall mounting: exactly as horizontal only: two rails and two brackets
- no stand: mounting of the furnace is entirely at the customer's discretion, but if the furnace is to be used at 1100°C or more in a horizontal position, then the face of the cylinder opposite to the terminal cover should be uppermost. Failure to position this face uppermost can lead to high case temperatures, and the customer may need to provide additional operator protection from hot surfaces.
- horizontal with heavy tubes: the rails fix to the base and the horizontal tube supports to the rails

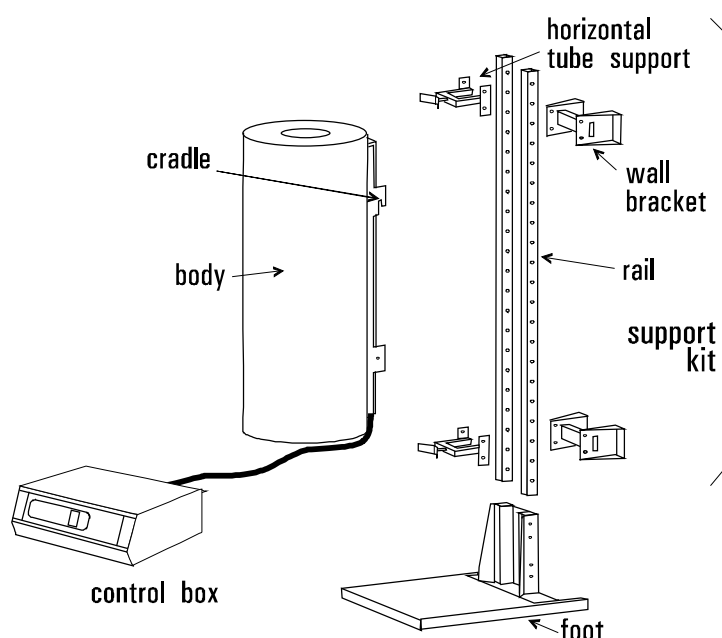

G range - versatile

2.5 Work Tubes and Fittings

Tubes of various diameters and lengths may be fitted.

Type C: minimum length for the furnace

Type D: 300mm longer than C, to allow for the fitting of end seals.

A pair of removable “tube adaptors” (or “end adaptors”) form part of the end insulation. These may be blank (no hole) or may have a hole to suit a work tube, depending on the customer order. Additional adaptors may be ordered to suit different work tube sizes. Check that the end adaptors are correct for the tube: if not, seek advice from Carbolite. Small alterations to the hole in the adaptors may be made with a file, but first read the section on ceramic fibre safety (5.2).

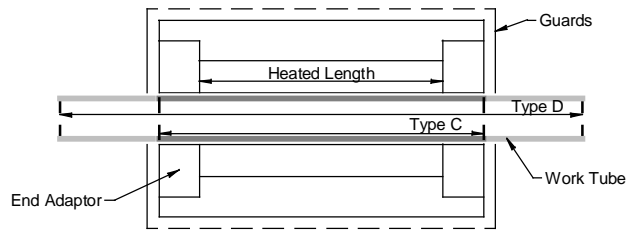

To insert a work tube it is often convenient to use a long pole (such as a broom handle) to guide it into the far end of the furnace.

For optimum temperature uniformity, insulating plugs should be placed in the tube ends as shown in fig.1. With an extended work tube (type D), the stem of the plug assembly should line up with the end of the tube as in fig.2. Alignment of radiation shields is similar to that of plugs.

If stainless steel seals with gas inlets are supplied they are to be fitted as shown in fig.3; the stem of any insulating plug should touch the seal. For vertical use a hook and eye arrangement holds the upper insulating plug assembly (in some cases a gland nut may alternatively be used).

Horizontal use: if heavy fittings are to be clamped to the end of an extended work tube they can increase the bending stress at the centre of the tube. Support such fittings in such a way that expansion of the tube is allowed. A horizontal tube support kit can be supplied for this purpose (in the versatile models the kit includes supports).

If a metal work tube is being used in the furnace, ensure that it is earthed. See the safety warning in section 3.4.

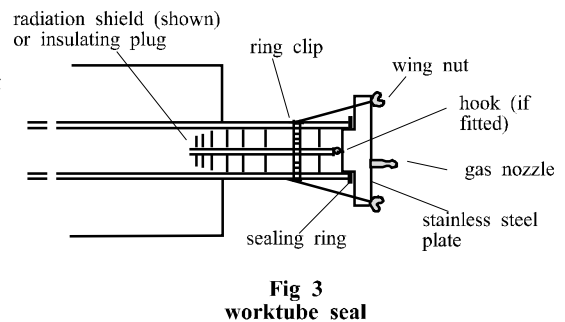
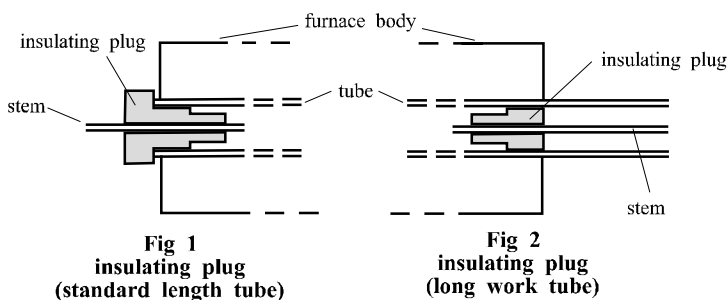

2.6 Electrical Connections

Connection by a qualified electrician is recommended.

All furnaces covered by this manual may be ordered for single phase A.C. supply, which may be Live to Neutral non-reversible, Live to Neutral reversible or Live to Live. The 2-element models (-/300) can be supplied for use on two phases of a 3-phase+N supply, and the 3-element models (-/450) for three phases of a 3-phase+N supply or a delta supply up to 240V. From -/600 upwards all the G-range are made with “universal” wiring, such that they may be reconfigured between 1phase, 3-phase+N and 3-phase delta. They are, however, factory set to the ordered supply.

Check the furnace rating label before connection. If the supply voltage and phase does not agree with the rating label, then read section 2.7 – it may be possible to reconfigure the furnace and/or adjust the power.

The supply should be fused at the next standard size equal to or higher than the design amperage. See section 8.1. Where a supply cable is present there are internal supply fuses, in which case customer fusing is preferred but not essential.

If a supply cable is fitted it may be connected to an isolator or fitted with a line plug. Where no supply cable is fitted a permanent connection to a fused and isolated supply should be made to the internal terminals after temporary removal of the furnace back panel. A line plug should be within reach of the operator, and should be quickly removable. An isolating switch should operate on both conductors (single phase) or on all live conductors (three phase), and should be within reach of the operator.

CONNECTION DETAILS			<i>supply type</i>	
Supply	Terminal label	Cable colour	<i>Live-Neutral</i>	<i>Reversible or Live-Live</i>
1-phase	L	Brown	To live	to either power conductor
	N	Blue	To neutral	to the other power conductor
	PE	Green/Yellow	To earth (ground)	to earth (ground)
supply	Terminal label	Cable colour		
2- or 3-phase	L1	Black	to phase 1	
	L2	Black	to phase 2	
	L3	Black	to phase 3 <i>except 2-phase</i>	
	N	Light Blue	to neutral <i>except delta</i>	
	PE	Green/Yellow	to earth (ground)	

The supply MUST incorporate an earth (ground).

2.7 Reconfiguring and Adjusting for Voltage.

In the instructions below, “controllers” means the single element controller in the single zone modes, or the three element controllers in the 3-zone models. The overtemperature controller (where fitted) is not affected.

Models -/300

The standard single-phase models can operate over the voltage range 200V-240V. The 2-phase models can operate over the range 380/220V to 415/240V. The furnace is wired according to the original order and conversion from 1-phase to 2-phase is not possible. To check for voltage setting within the appropriate range, or to change to another setting, follow the instructions in section 8.2.

Models -/450 (1-phase)

The standard single-phase models can operate over the voltage range 200V-240V. The 3-phase models can operate over the range 380/220V to 415/240V. The furnace is wired according to the original order and conversion from 1-phase to 3-phase is not possible. To check for voltage setting within the appropriate range, or to change to another setting, follow the instructions in section 8.2.

Models -/600 to -/1200 (and -/450 3-phase)

These models are all made to a “universal” wiring scheme, whereby the customer may, if necessary, convert between single- and 3-phase supplies of the following types:

- 200 to 240V single-phase
- 200 to 240V 3-phase without neutral (delta)
- 380/220 to 415/240V 3-phase with neutral

To reconfigure the wiring to change between types of supply, see section 7.7.

To check the setting for the voltage within the range, or to alter it, follow the instructions in section 8.2.

Special Voltages

The furnaces can be specially made to suit certain special voltages, such as 440/254 or 480/277.

Because of unbalanced phases the furnaces cannot be made to suit 3-phase without neutral of 380V or above.

At the time of writing, 110-120V models are not available.

Furnaces made for special voltages are generally not convertible between configurations and voltages.

3.0 OPERATION

The instructions for operating the temperature controller are given in a separate manual. If the furnace is fitted with a time switch, see also the supplementary manual MS0. If cascade control is fitted, see the supplementary manual MS07.

3.1 Operating Cycle

The furnace is fitted with a combined Supply light and Instrument switch. The light is on whenever the furnace is connected to the supply. The switch cuts off power to the control circuit. There is also a Heater switch that can be used to disconnect power to the elements.

Connect the furnace to the electrical supply. The Supply light should glow.

Operate the instrument switch to activate the temperature controller; the **O** position is *off*, the **I** position *on*. The controller becomes illuminated and goes through a short test cycle.

Single zone models, GHA and GVA: Set the temperature controller to the desired setpoint or program - see the controller manual.

3-zone models, GHC and GVC, with control methods A & B: Set the slave (end zone) controllers to the desired offset temperature, usually zero. Set the main (central) temperature controller to the desired setpoint or program. See section 3.2 and/or the separate manual(s) for the controller(s).

3-zone models, GHC and GVC, with control method C: Set the three controllers to the desired temperatures. See the separate manual(s) for the controller(s).

Overtemperature option only. If the overtemperature controller has not yet been set as required, set it and activate it according to the instructions in the controller manual.

Switch on the Heater switch, located on the instrument panel. Unless a time switch is fitted and is off, the furnace starts to heat up. The Heat light(s) glow steadily at first and then flash as the furnace approaches the desired temperature or a program setpoint.

Overtemperature option only. If the overtemperature trip operates then an indicator in the overtemperature controller flashes, and the heating elements are isolated. Find and correct the cause before resetting the overtemperature controller according to the instructions supplied.

To switch off power to the heating elements, use the Heater Switch. To switch the furnace off, use both the Heater switch and the Instrument switch. If the furnace is to be left off, isolate it from the electrical supply.

3.2 3-zone Control Methods – models GHC and GVC

These models are typically designed to achieve an extended uniform temperature zone by the use of three control zones. The control zones are typically linked so that the end controllers follow the central controller in a master-slave approach, in one of two ways. Alternatively independent control zones may be ordered. There are thus three control methods (A, B & C).

Zone lengths: The normal end-zone length for all the 3-zone models is 1 element (150mm). The “equal zone” models (with suffix E after the model name) have longer end-zones of 2 elements (300mm); only the models 12/450 and 12/900E have truly equal zone lengths. Any of the control methods can apply to equal zone models, just as they can to the standard models.

Achieving temperature differences across the zones: a small temperature difference may be achievable, but this is limited by the effect of radiated heat inside the furnace body, and in the work tube, and depends also upon the furnace contents.

A. Back-to-Back Thermocouples

This is the most commonly supplied option.

The central zone of the work tube is controlled directly by the central temperature controller. Each end zone thermocouple is wired in opposition to a central reference thermocouple, and the small voltage resulting when the zones are at different temperatures is used by the end zone controller.

There are thus four thermocouples. The circuit diagram in section 7.6 (A) shows the thermocouple arrangement.

Set the “setpoint” of the end zone controllers to zero. Alternatively, a small temperature difference (offset) can be created by setting a non-zero value, but the sum of the main controller set-point and the slave controller offset **MUST NOT** exceed the furnace maximum temperature. The “measured temperature” display shows the actual offset.

To alter the setpoint (with the display at “home”), press Down **Q** or Up **P** once to display the setpoint; press again or hold down to adjust it. The display returns to the measured temperature offset when no key is pressed for 0.5 seconds.

Sometimes a furnace using this type of control does not cool down: the end controllers try to remain at the current central temperature. Should this occur, contact Carbolite’s technical department.

2132 Slave Controller Navigation Diagram

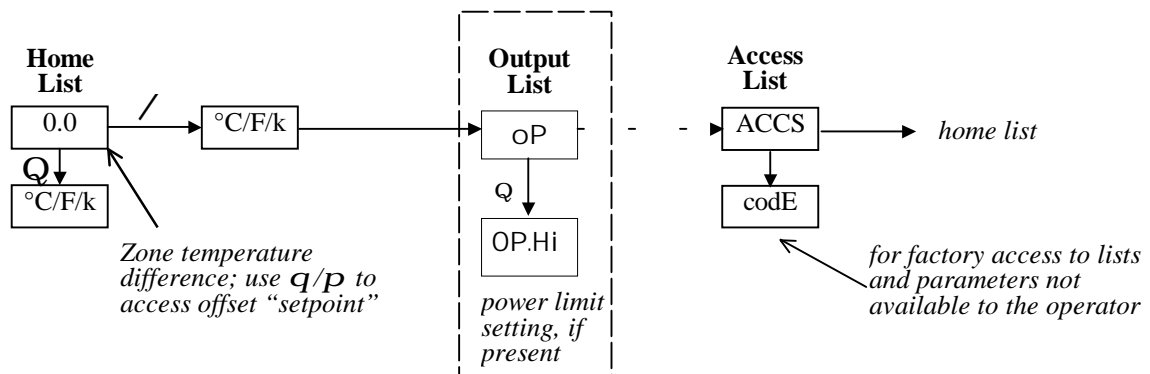

B. Retransmission of Setpoint

When this is ordered there are three independent thermocouples connected to the three controllers, as in 7.6 (C); the controllers are linked together, the central controller communicating the desired setpoint to the end controllers.

The communication between the controllers of the Eurotherm 2000 series is known as PDS. The wiring connections between the controllers are as follows:

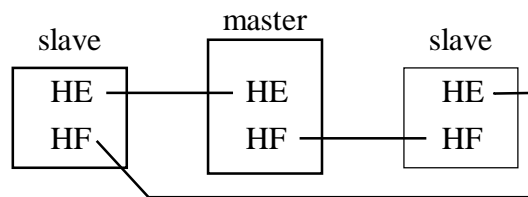

Additional communication modules are fitted in the controllers, rather than an additional thermocouple as in A.

It is possible to switch off the linked control and allow the controllers to work independently. On the end-zone controllers, scroll down to L-r and press Up or Down to alter the value from rmt (remote) to Loc (local). There is no need to alter the centre controller.

C. Independent Control

In this case the three controllers are completely independent. Remember that it is not possible to maintain very different zone temperatures because of heat transfer within the furnace body and work tube.

3.3 General Operating Advice

Heating element life is shortened by use at temperatures close to maximum. Do not leave the furnace at high temperature when not required. The maximum temperature is shown on the rating label and on the back page of this manual.

3.4 Operator Safety

 The ceramic materials used in furnace manufacture become electrically conductive to some extent at high temperatures. Also, there are partially exposed heating coils in the chamber. **DO NOT** use any conductive tools within the work tube without isolating it. If a metal work tube is used, it must be earthed (grounded).

 Switch off the Heater switch whenever loading or unloading the furnace. The elements are isolated when the Heater switch is OFF. This switch cuts both sides of the circuit directly or via a contactor (a contactor is used in models where the rated current exceeds 16 Amps).

3.5 Tube Life

A ceramic work tube may be cracked if workpieces are inserted too quickly or at temperatures below 900°C when the tube is more brittle. Large pieces should also be heated slowly to ensure that large temperature differences do not arise.

Poor thermal contact should be encouraged between the workpiece and the tube; crucibles or boats should be of low thermal mass and should have feet to reduce the contact with the tube (fig. 4).

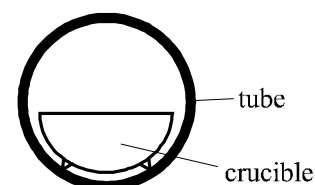

Fig 4
avoidance of thermal contact

Do not set too high a heating rate. Large diameter tubes are more susceptible to thermal shock than smaller. Tubes that extend beyond the heated part of the furnace are more at risk. A general rule for maximum heating rate is 400/internal diameter (°C/min); for 75mm i/d tubes this comes to 5°C per minute. The controller can be set to limit the heating rate.

3.6 Pressure

Work tubes are not able to accept high internal pressure. When gas seals or similar fittings are in use, the gas pressure should be restricted to a maximum of 0.2 bar (3 psi). A pressure of about half of that should normally be sufficient to achieve the desired flow rate. The customer must ensure that the exhaust path from the tube is not blocked, so that excess pressure does not occur.

3.7 Gas Tightness

Work tubes of IAP material are impervious. Sillimanite may look similar but is porous. Ensure that the correct tube material is in use before connecting and using gases, other than inert gases such as nitrogen.

3.8 Running at Low Temperatures

Better control when running the furnace at a low temperature may often be achieved by adjusting the power limit to a low level. No hard and fast rules can be given, but, as an example, to run at temperatures only up to 600°C try a power limit of 50%. Control stability may fall off again if a setting below about 40% is used.

Before changing the power limit, record its factory setting for possible future use. To change the power limit, see sections 8.2.

4.0 MAINTENANCE

4.1 General Maintenance

No routine maintenance is required. The outer surfaces may be cleaned with a damp cloth. Do not allow water to enter the interior of the case, tube or control box. Do not clean with organic solvents.

4.2 Calibration

After prolonged use the controller and/or thermocouple could require recalibration. This would be important for processes that require accurate temperature readings or that use the furnace close to its maximum temperature. A quick check using an independent thermocouple and temperature indicator should be made from time to time to determine whether full calibration is required. These items can be supplied by Carbolite.

Depending on the controller, the controller manual may contain calibration instructions.

4.3 After Sales Service

Carbolite's service division (Thermal Engineering Services) has a team of Service Engineers capable of repair, calibration and preventive maintenance of furnace and oven products at our customers' premises throughout the world. We also sell spares by mail order. A telephone call or fax often enables a fault to be diagnosed and the necessary spare part despatched.

Each furnace has its own record card at Carbolite. In all correspondence please quote the serial number, model type and voltage given on the rating label of the furnace. The serial number and model type are also given on the front of this booklet when supplied with a furnace.

To contact Thermal Engineering Services or Carbolite see the back page of this manual.

4.4 Recommended Spares Kits

Carbolite can supply individual spares, or a kit of the items most likely to be required. Ordering a kit in advance can save time in the event of a breakdown.

Models GHA, GVA: Each kit comprises one thermocouple, one solid state relay, and a heating element of each wattage (normally 2 elements, but 1 in the case of model -/300).

Models GHC, GVC: Each kit comprises two thermocouples of different length, one solid state relay, and two heating elements (1 of each wattage).

When ordering spares please quote the model details: model type and serial number.

5.0 REPAIRS & REPLACEMENTS

5.1 Safety Warning – Disconnection from Supply

Always ensure that the furnace is disconnected from the supply before repair work is carried out.

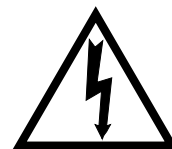

5.2 Safety Warning - Refractory Fibrous Insulation

This furnace contains refractory fibres in its thermal insulation. These materials may be in the form of fibre blanket or felt, vacuum formed board or shapes, mineral wool slab or loose fill fibre.



Normal use of the furnace does not result in any significant level of airborne dust from these materials, but much higher levels may be encountered during maintenance or repair.

Whilst there is no evidence of any long term health hazards, we strongly recommend that safety precautions are taken whenever the materials are handled.

Exposure to dust from fibre which has been used at high temperatures may cause respiratory disease.

When handling fibre always use an approved mask, eye protection, gloves and long sleeved clothing.

Avoid breaking up waste material. Dispose of waste fibre in sealed containers.

After handling rinse exposed skin with water before washing gently with soap (not detergent). Wash work clothing separately.

Before commencing any major repairs we recommend reference to the European Ceramic Fibre Industry Association Bulletin No. 11 and the UK Health and Safety Executive Guidance Note EH46.

We can provide further information on request. Alternatively our service division can quote for any repairs to be carried out at your premises or ours.

5.3 Temperature Controller Replacement

201. This controller is fitted to the back of the control panel; in many models this can be separated from the base by removal of two screws.



Before handling the controller: **wear an anti-static wrist strap** or otherwise avoid any possibility of damage to the unit by static electricity.

Refer to the detailed instructions supplied with the replacement controller.

2132, 2416, 2408 etc. Ease apart the two lugs at the side; grip the instrument and withdraw it from its sleeve; push in the replacement.

5.4 Solid-state Relay Replacement

Disconnect the furnace from the supply and remove the back panel from the base or control box..

Make a note of how the wires are connected to the solid state relay, and disconnect them.

Remove the solid state relay (SSR) from the base panel or aluminium plate.

Replace and reconnect the solid state relay ensuring that the heat-conducting thermal pad is sandwiched between the relay and the base panel or aluminium plate. Alternatively a thin layer of white, heat-conducting silicon paste may be applied between the new relay and the plate.

Replace the removed panel.

Users of older furnaces may be familiar with the circular “MOV” attached to the SSR. This is no longer required with current SSRs.

5.5 Thermocouple Replacement

The coverings and guards which must be removed to gain access to the thermocouple depend on the model, and possibly other options and fittings. For the horizontal models it will be necessary to separate the cylindrical body from the base, or remove some guards under the protruding ends of the body. For the versatile models it will be necessary to dismount the furnace from its stand, and remove the mesh terminal cover.

Disconnect the furnace from the supply, and separate the furnace body and/or remove covers and guards as necessary.

Make a note of the thermocouple connections. Type N colour codings are:

<i>negative</i>	<i>positive (type N)</i>
white	pink

Disconnect the thermocouple from its terminal block.

Withdraw the thermocouple from the end of the furnace: ensure no broken bits remain.

If the thermocouple is supplied straight or coiled, bend it carefully to match the shape of the original (working from the terminal end). Should the length differ from that of the original this will usually not be important provided that the thermocouple tip is within a tube diameter's distance from the furnace centre. End zone thermocouple tips should be about two-thirds of the way along the end element.

Insert the new thermocouple into position, restoring any removed porcelain spacers, and ensuring correct polarity.

Re-assemble the furnace.

5.6 Element Replacement



Please see safety note 5.2 - please wear a face mask.

Disconnect the furnace from the electrical supply.

Remove all outer guards, meshes and terminal covers from the furnace body. For a horizontally mounted furnace remove the furnace body from its base; to reach the bolts or screws that fix the body to the base, remove the back panel from the base.

Disconnect all electrical leads from the terminal blocks on the furnace case. Note the colours and positions of the connecting leads to enable correct reassembly. Take care not to crack porcelain terminal blocks - use two spanners where appropriate.

Remove the thermocouple(s).

Lay the furnace body horizontally with the split in the cylindrical case uppermost. Remove the two metal end-caps from the body. Undo the self-tapping screws that hold the terminal strip to the case join. The case will spring open slightly. Remove the ceramic board disc from one.

Cut through the outer wrap of blanket insulation. Note how the element tails are connected and disconnect all of them. Lift out the elements through the end of the cylindrical case.

Check the cylindrical case and clean out as appropriate.

Remove any insulation sleeving from the tails of the old element and fit to the replacement element.

Slide in the new element(s). Close up the furnace again, refitting the terminal strip and the end-caps. Any cut made in the insulation should close up completely: if the insulation appears loose or damaged in any way, please contact our service division.

Note on Elements

The end and centre elements look the same but have different wattages. On standard models the two end elements are 1170W, and all the centre elements are 780W. Ensure that elements are correctly replaced.

Reverse the rest of the disassembly process. Take care to make all connections to the correct terminals. Do not overtighten the connectors in porcelain terminal blocks.

Let the furnace heat up at its maximum rate to 900°C without interruption, and then soak for 1 hour. Fumes may be emitted: this should be done in conditions of good ventilation.

Check that the furnace is controlling properly to rule out the possibility that the element failed because of a fault in the control system.

If you have any problems with this procedure, please contact our service division.

5.7 Fuse Replacement

Fuses are marked on the circuit diagram (section 7.0) with type codes, e.g. F1, F2. A list of the correct fuses is given in section 8.1. *Depending on model and voltage, the different fuse types may or may not be fitted.*

If any fuse has failed, it is advisable for an electrician to check the internal circuits.

Replace any failed fuses with the correct type. For safety reasons do not fit larger capacity fuses without first consulting Carbolite.

The fuses are near the cable entry point, and access is by removal of the back panel of the base or control box.

6.0 FAULT ANALYSIS

A. Furnace Does Not Heat Up

- | | | | |
|----|---|--|--|
| 1. | The HEAT light is ON | à The heating element has failed | à Check also that the SSR is working correctly |
| 2. | The HEAT light is OFF | The controller shows a very high temperature or a code such as S.br | à The thermocouple has broken or has a wiring fault |
| | | The controller shows a low temperature | à The heater switch may be faulty or need adjustment |
| | | | à The contactor (if fitted) may be faulty |
| | | | à The SSR could be failing to switch on due to internal failure, faulty logic wiring from the controller, or faulty controller |
| | There are no lights glowing on the controller | à The SUPPLY light is ON | à The controller may be faulty or not receiving a supply due to a faulty switch or a wiring fault |
| | | à The SUPPLY light is OFF | à Check the supply fuses and any fuses in the furnace control compartment |

B. Furnace Overheats

- | | | | |
|----|---|---|--|
| 1. | The HEAT light goes OFF with the instrument switch | à The controller shows a very high temperature | à The controller is faulty |
| | | à The controller shows a low temperature | à The thermocouple may have been shorted out or may have been moved out of the heating chamber |
| | | | à The thermocouple may be mounted the wrong way round |
| | | | à The controller may be faulty |
| 2. | The HEAT light does not go off with the instrument switch | à The SSR has failed "ON" | à Check for an accidental wiring fault which could have overloaded the SSR |

7.0 CIRCUIT DIAGRAMS

For standard furnaces -/600 upwards, and -/450 if ordered 3-phase, see 7.7; for 3-zone see also 7.6.

7.1 Single Phase (models -/300 & -/450)

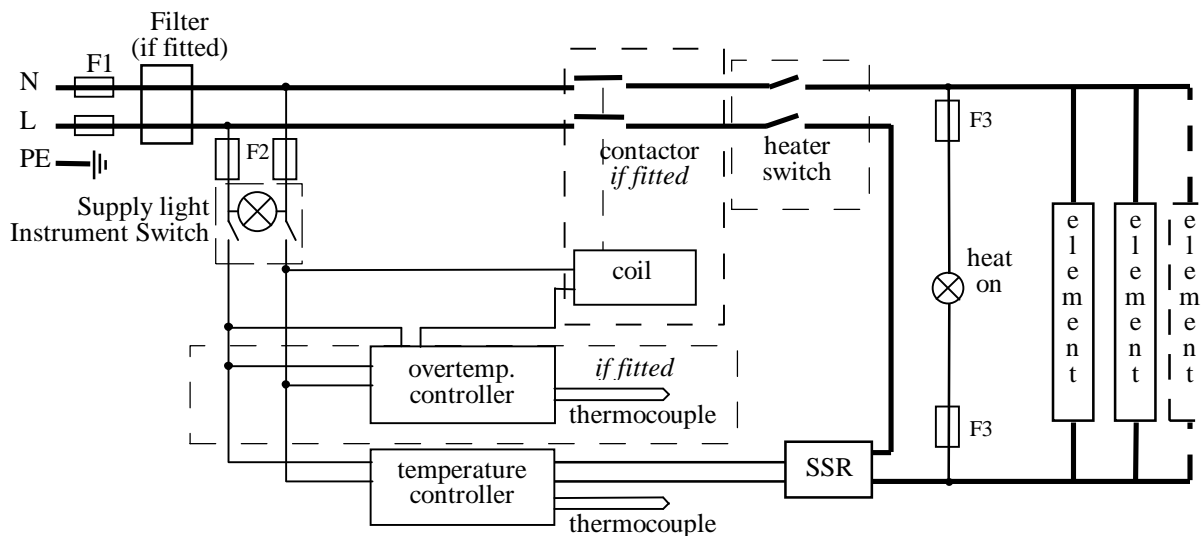

7.2 2-phase with neutral (model -/300)

As 7.3, with phase L3 not present, and with two SSRs and element circuits. In models up to 25A safety switches type A are fitted in the L1 and L2 circuits instead of type B in the contactor coil circuit.

7.3 3-phase with neutral

In most instances this diagram does not apply. See “universal” wiring, section 7.7. It may, however, apply if non-standard models are ordered, or for high voltages with the addition of a control transformer as shown in 7.5.

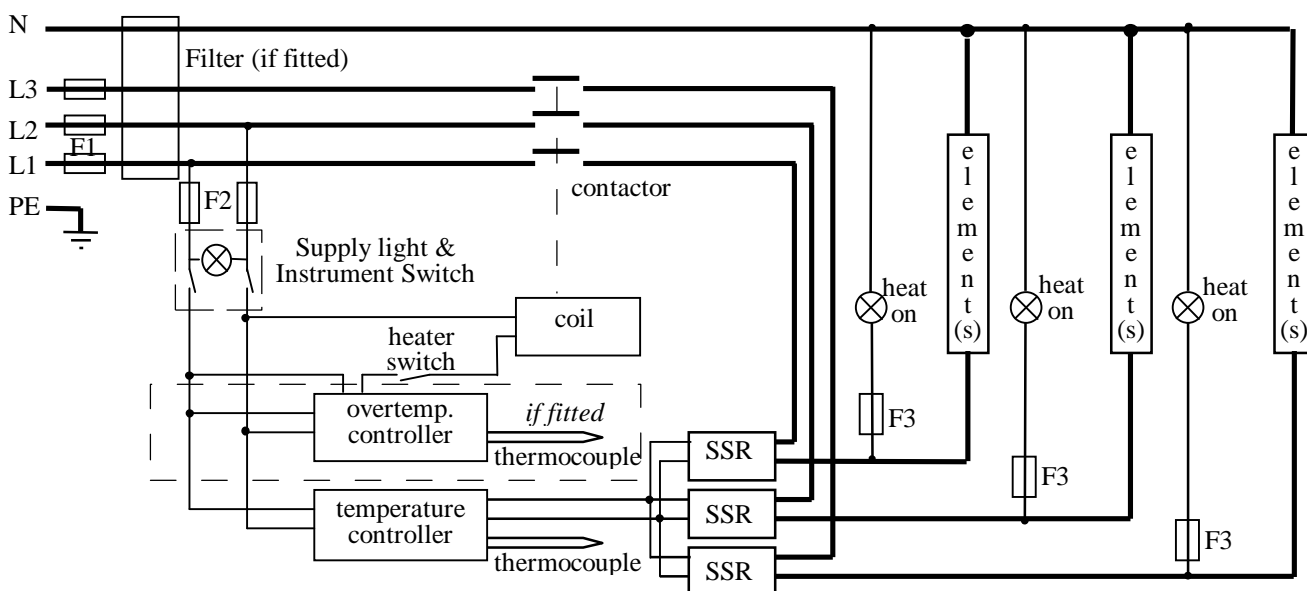

7.4 3-phase without neutral (delta)

In most instances this diagram does not apply. See 7.7. It may apply if non-standard models are ordered.

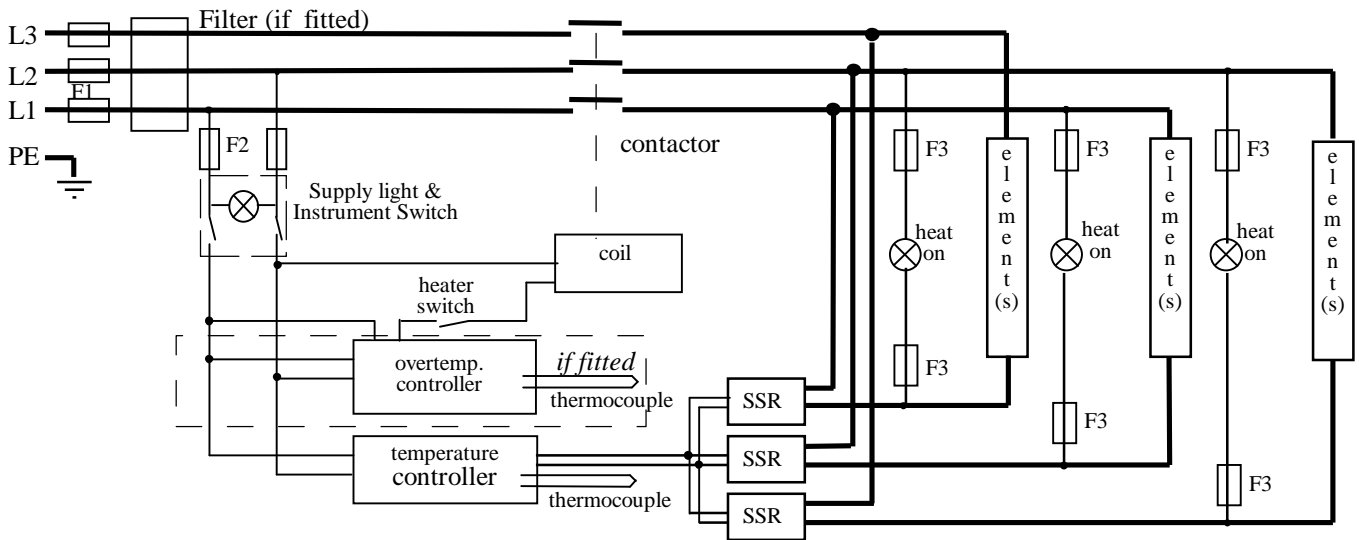

7.5 Higher Voltages

For 254V or above 1-phase or 440/254V or above 3-phase an isolating transformer is fitted in the control circuit after the F2 fuses.

This addition may be applied to diagrams 7.1, or 7.3.

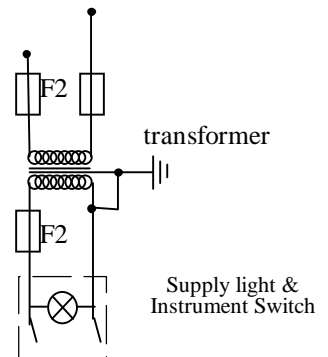

7.6 Three-Zone models

The element circuit in the 3-zone versions remains the same as in diagrams 7.3, 7.4 or 7.7, but the control circuit contains three controllers and additional thermocouples. The sub-circuits for the three control methods referred to in section 3.2 are:

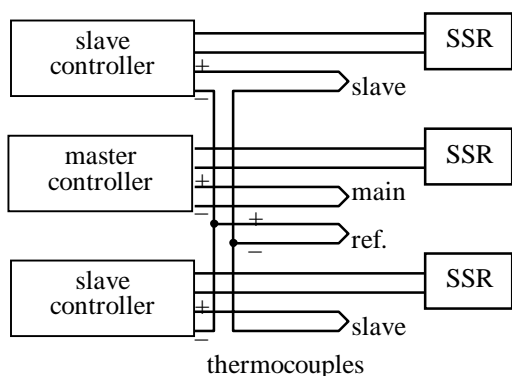

Control type A

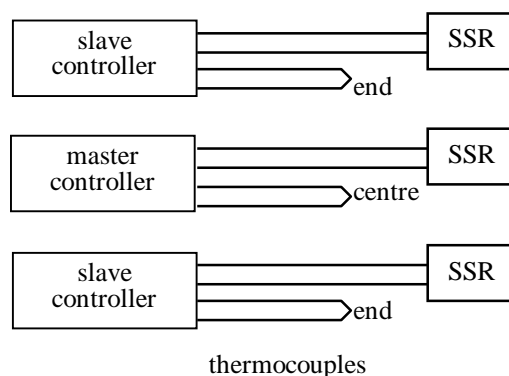

Control type C

Control type B - the diagram is like C, plus the connections between the controllers indicated in section 3.2 C.

7.7 **3-phase “universal” wiring (models -/600 and over, & /-450 3-phase)**

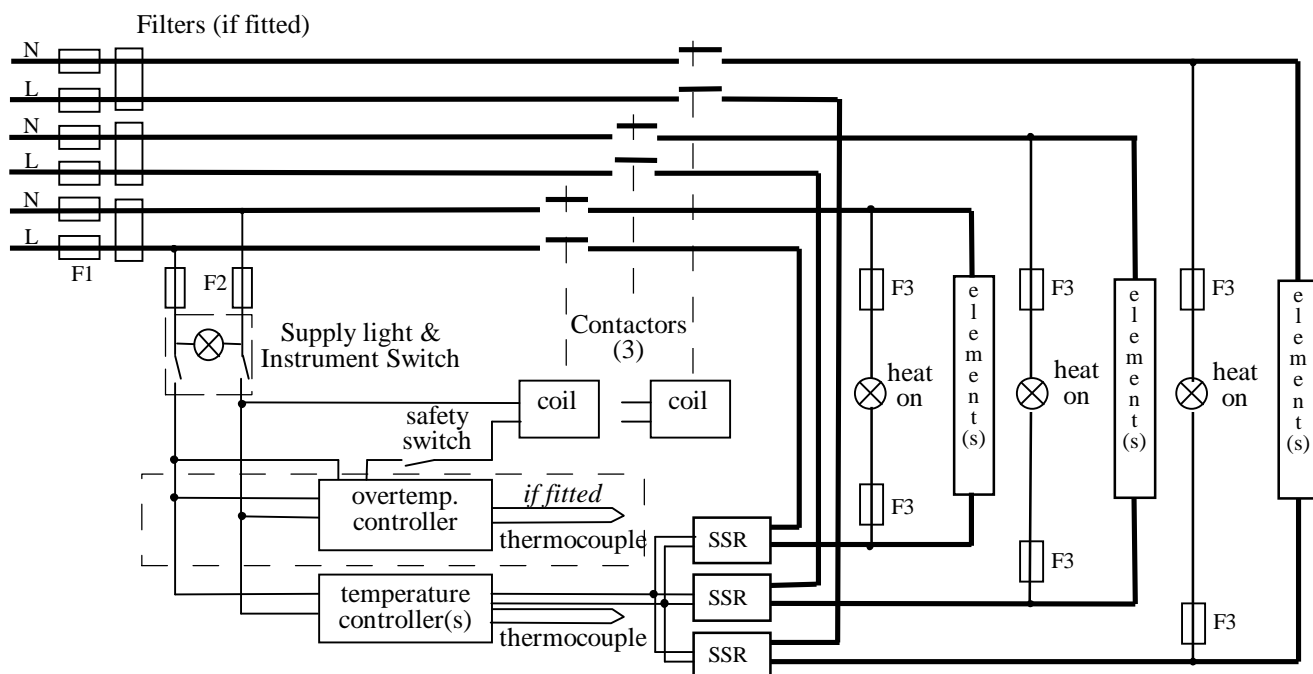

Fuses F1 are always present in this wiring design.
 Fuses F2 are always present in G range models.
 Fuses F3 are absent in standard G range models: wire size not reduced.

3-phase + neutral

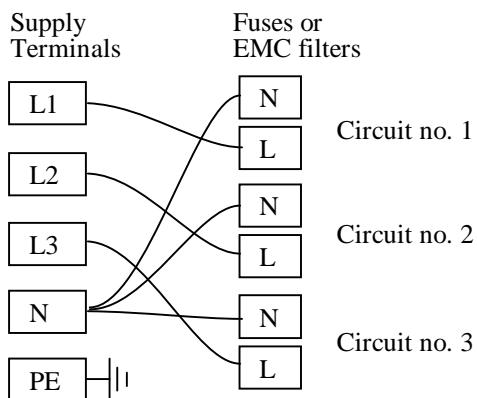

3-phase delta

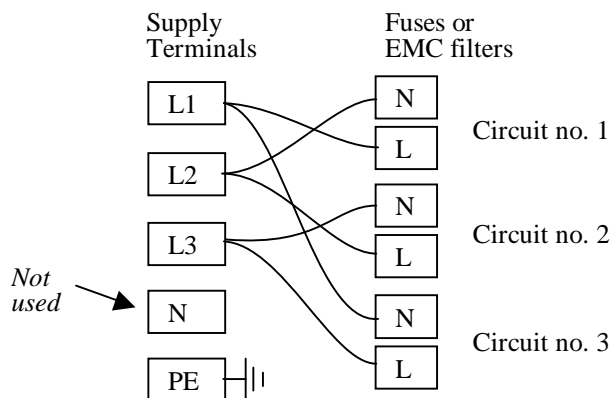

1-phase

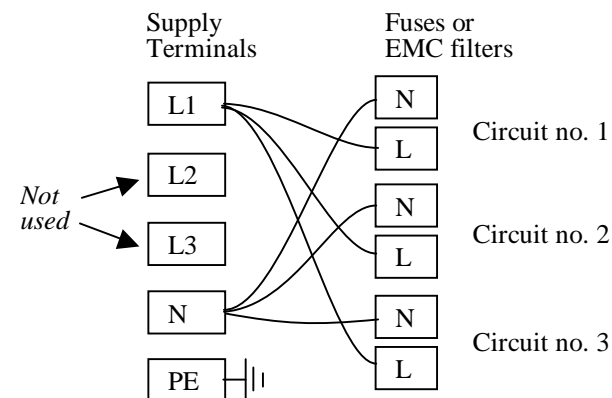

A model made to this diagram can be converted by the customer between the following supply voltages:
 between 3-phase + neutral in the range 380/220V – 415/240V
 and 3-phase delta in the range 200V – 240V
 and single phase in the range 200V – 240V
 See also section 8.2 if there is a voltage change.

8.0 FUSES & POWER SETTINGS

8.1 Fuses *F1-F3: Refer to the circuit diagrams.*

<i>F1</i>	Internal supply fuses	Fitted to all G range models. For “universal” wiring each circuit has 2 fuses, in most cases fitted on board to the EMC filter.	on-board and up to 16 Amps: 32mm x 6mm type F
<i>F2</i>	Auxiliary circuit fuses	Fitted to all G range models. In most cases fitted on board to the EMC filter.	2 Amps On board: 20mm x 5mm type F Other: 32mm x 6mm type F
<i>F3</i>	Heat Light fuses	Not fitted in standard G range models (wire size does not reduce).	if fitted: 32mm x 6mm type F
	Customer fuses	Required to protect customer supply circuit and lead.	See rating label for amperage; see table below for minimum supply and fuse rating.

Table of internal fuse and external supply ratings.

The phases are generally unequal on these models. A figure equal to or exceeding the highest phase current is shown, and the wiring and fusing should match or exceed this figure. The function of the customer’s (external) fuse is to protect the customer’s wiring.

Model	internal supply fuses	external: 1-phase 200-240V	external: 3-phase+N 380/220-415/240V	external: 3-phase delta 200-240V
GHA, GVA 12/300	2 x 12.5A	12A	--	--
as above, 2-ph+N	1 x 12.5A	--	6A/ph	--
GHA, GVA 12/450	2 x 16A	15A	--	--
as above, 3-phase	6 x 7A	--	6A/ph	10A/ph
GHA, GVA 12/600	6 x 10A	20A	10A/ph	12A/ph
GHA, GVA 12/750	6 x 10A	25A	10A/ph	15A/ph
GHA, GVA 12/900	6 x 10A	30A	10A/ph	20A/ph
GHA, GVA 12/1050	6 x 12.5A	30A	12A/ph	20A/ph
GHA, GVA 12/1200	6 x 12.5A	35A	12A/ph	20A/ph
GHC, GVC 12/450	2 x 16A	15A	--	--
as above, 3-phase	6 x 7A	--	6A/ph	10A/ph
GHC, GVC 12/600	6 x 7A	20A	10A/ph	12A/ph
GHC, GVC 12/750	6 x 12.5A	25A	12A/ph	15A/ph
GHC, GVC 12/900	6 x 12.5A	30A	12A/ph	20A/ph
GHC, GVC 12/1050	6 x 12.5A	30A	12A/ph	20A/ph
GHC, GVC 12/1200	6 x 12.5A	35A	12A/ph	20A/ph
GHC, GVC 12/900E	6 x 10	30A	10A/ph	20A/ph
GHC, GVC 12/1050E	6 x 12.5A	30A	12A/ph	20A/ph
GHC, GVC 12/1200E	6 x 16A	35A	15A/ph	25A/ph

8.2 Power Settings & Adjustment

The furnace control system incorporates electronic power limiting. The power limit parameter OP.Hi is accessible to the operator, and can be used to match the furnace to the actual supply voltage.

All standard models covered by this manual are fitted with 208V elements and are designed for use over the range of voltages 200V-240V; the power limit parameter is set accordingly. These models may be relocated to a different voltage within the range

The power limit depends on the voltage s follows.

200V	208V	220V, 380V	230V, 400V	240V, 415V	254V, 440V	277V, 480V
100	100	89	82	75	67	56

Non-standard models

Special versions (i.e. with non-standard heating elements) may not follow the table above. Check the initial setting (see below) or contact Carbolite if in doubt.

Power Adjustment

Set the Heater Switch to Off to prevent heating while adjusting the power limit.

Press Page / until oP (output list) is displayed. Press Scroll Q until OP.Hi (Output High) is displayed. Press Down **q** or Up **p** once to display the value of OP.Hi (it is good practice to write down the original value). To alter the parameter to the desired value use Down **q** or Up **p**.

A power setting of zero prevents the furnace from heating: useful for demonstrating the controls without taking power.

Do not increase the power limit simply “to get more power”. The elements could burn out, or a fuse could blow.

9.0 SPECIFICATIONS

Carbolite reserves the right to change specifications without notice.

9.1 Models Covered by this Manual

GHA models – horizontal single-zone tube furnaces with controls in integral base

GVA models – versatile single-zone tube furnaces with controls in integral base

GHC models – horizontal three-zone tube furnaces with controls in integral base

GVC models – versatile three-zone tube furnaces with controls in integral base

All models have cylindrical elements with wire formed in the surface of the insulation material.

All models have can accept work tubes up to a maximum outside diameter of 170mm.

All models have a maximum operating temperature of 1200°C (1100° continuous).

Model names are of the type “GHA 12/300” where 300 is the heated length. Sizes range from 300mm heated length (GHA/GVA) or 450mm (GHC/GVC) to 1200mm (all models).

Heated Length (mm)	Max. Power (W)	Minimum work tube length (mm)	Type C work tube (mm)	Type D work tube (mm)
300	2340	480	600	900
450	3120	630	750	1050
500	3900	780	900	1200
750	4680	930	1050	1350
900	5460	1080	1200	1500
1050	6240	1230	1350	1650
1200	7020	1380	1500	1800

Work tubes may be supplied in any commercially available size up to the maximum of 170mm o/d. Type C protrudes about 40mm from each end of the furnace (from the end guards), while type D allows for the fitting of gas seals or other attachments.

9.2 Environment

The furnaces contain electrical parts and should be stored and used in indoor conditions as follows:

temperature: 5°C - 40°C

relative humidity: maximum 80% up to 31°C decreasing linearly to 50% at 40°C

The products covered in this manual are only a small part of the wide range of ovens, chamber furnaces and tube furnaces manufactured by Carbolite for laboratory and industrial use. For further details of our standard or custom built products please contact us at the address below, or ask your nearest stockist.

For preventive maintenance, repair and calibration of all Furnace and Oven products, please contact:

Thermal Engineering Services

Telephone: UK: 0845 3308035 Int: +44 1433 623335
Fax: UK: 0845 3308036 Int: +44 1433 623336
Email: service@thermalservice.com



MF48-1.1

12/7/04

G range

Carbolite, Parsons Lane, Hope, Hope Valley, S33 6RB, England.

Telephone: (01433) 620011

Int: +44 1433 620011

Facsimile: (01433) 621198

Int: +44 1433 621198

E-mail: info@carbolite.com