



Installation, Operation & Maintenance Instructions

900°C Tube Furnace
type MTF 9/15

This manual is for the guidance of operators of the above Carbolite product and should be read before the furnace is connected to the electricity supply.

CONTENTS

section		page
1.0	Symbols & Warnings	2
2.0	Installation	3
3.0	Operating Instructions	4
4.0	Controller Operation	5
5.0	Maintenance	10
6.0	Repairs & Replacements	11
7.0	Fault Analysis	13
8.0	Circuit Diagram	14
9.0	Fuses & Power Control	15
10.0	Specifications	16

This manual should supply all the information required for safe and trouble-free furnace operation. Information on controller operation is included.



1.0 SYMBOLS & WARNINGS

1.1 Switches and Lights



Supply Light: when the furnace is connected to the electrical supply the light in the adjacent switch glows



Heat Light: the adjacent light glows or flashes to indicate that power is being supplied to the elements

1.2 Warning Symbols

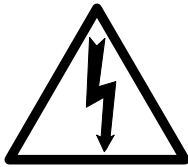

DANGER of electrical shock— read any warning printed by this symbol.



DANGER – hot surface. Read any warning printed by this symbol.
WARNING: all surfaces of a furnace may be hot.



DANGER – read any warning printed by this symbol.

2.0 INSTALLATION

2.1 Unpacking & Setting Up

Unpack the furnace carefully and remove any packing from inside the tube.

Place the furnace in a well ventilated area, away from other sources of heat, on a surface which is resistant to accidental spillage of hot materials. Do not use the furnace on an inflammable surface.

Ensure that there is free space around the furnace. Do not obstruct any of the vents: they are needed to keep the controls cool.

Ensure that the furnace is placed in such a way that it can be quickly switched off or disconnected from the electrical supply - see below.

2.2 Electrical Connections

The furnace requires a single-phase A.C. supply with earth (ground). The supply may be Live to Neutral non-reversible, Live to Neutral with reversible plug, or Live to Live.

The voltage or range of voltages on which the furnace may be operated is given on the furnace rating label. Check that the supply voltage is compatible with the voltage on the label.

The supply should be fused at not more than 10 Amps, preferably 2 Amps.

The furnace is fitted with a supply cable which may be wired directly to an isolator which operates on both conductors, or fitted with a line plug which may be quickly disconnected from the supply.

The supply MUST incorporate an earth (ground).

Connect the supply as follows:

Cable colour	<i>supply type</i>	
	Live-Neutral	Reversible or Live-Live
Brown	to live	to either power conductor
Blue	to neutral	to the other power conductor
Green/Yellow	to earth	to earth

3.0 OPERATING INSTRUCTIONS

3.1 Operating Cycle

Switch on the electrical supply. The temperature controller will become illuminated and may now be adjusted as described in section 4.0.

The furnace will begin to heat up. The output light on the controller will flash steadily at first and then flash less as the furnace approaches the desired temperature.

To switch off power to the heating element, switch off or disconnect the supply.

3.2 General Operating Notes

Heating element life is shortened by use at temperatures close to maximum. Do not leave the furnace at high temperature when not required. The maximum temperature is shown on the furnace rating label and on the back page of this manual.

Materials such as waxes, case hardening compounds, melting fluxes and other reactive salts readily penetrate the ceramic tube and attack the wire element, causing premature failure.

3.3 Operator Safety

The ceramic materials used in furnace manufacture become electrically conductive to some extent at elevated temperatures. DO NOT use any conductive tools within the work tube without isolating the furnace, unless the tools are earthed (grounded).

Avoid burns. Carbolite can supply tongs, face masks, and heat resistant gloves. Before you remove a hot object from the furnace make sure you have a safe place to put it down.

4.0 CONTROLLER OPERATION

4.1 Eurotherm 2132

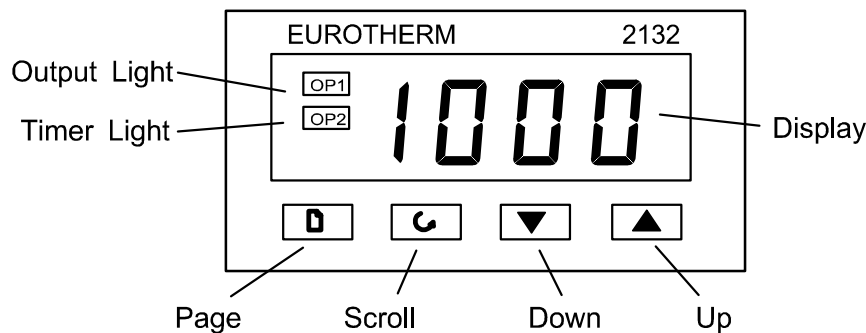

When switched on, the controller lights up, goes through a short test routine, and then displays the measured temperature and starts to control. The output light glows or flashes as heating occurs.



The **Page** key  allows access to parameter lists within the controller; most lists and parameters are hidden and cannot be accessed by the operator because they contain factory-set parameters which should not be changed.

A single press of the page key  displays the temperature units, normally set to °C; further presses reveal the lists indicated in the Navigation Diagram in section 4.6.

The **Scroll** key  allows access to the parameters within a list. Some parameters are display-only; others may be altered by the operator. Some parameters only appear in appropriate circumstances – for example, working setpoint does not appear if setpoint ramp rate is Off.

A single press of the scroll key  displays the temperature units; further presses reveal the parameters in the current list indicated in the Navigation Diagram.



To return to the Home list at any time, press Page  and Scroll  together, or wait for 45 seconds.

The **Down**  and **Up**  keys are used to alter the setpoint or other parameter values.





4.2 Basic Operation

Normally no operator action is required other than entering the setpoint, as the 2132 starts to control on being switched on, as described above.

4.3 Altering the Setpoint

With the display at “home”, showing the measured temperature, press Down  or Up  once to display the setpoint; press again or hold down to adjust it. The display returns to the measured temperature when no key is pressed for 0.5 seconds.

4.4 Stopping and Starting Control

It is possible to stop and start the controller without altering the setpoint. Press Scroll  until the legend $m-A$ (manual/auto) appears. In the 2132, manual means “off” and auto means “on”. Press Down  or Up  once to show the current on/off state: mAn for off, and $AuLo$ for on. Press  or  to change between manual and auto (off and on) as required.

Note that timer modes 1 & 3 set the controller to mAn at the end of the timing period. If the controller unexpectedly does not control it may be in manual, possibly as the result of previous use of the timer function.

4.5 Altering the Ramp Rate

It is possible to limit the rate of heating by setting a ramp rate only if the timer feature is not in use. To enable direct setting of the ramp rate, first ensure that the *StARt* parameter and *dWELL* parameter are both set to *OFF* (see sections 4.8 and 4.9).

Press Scroll \cup until the legend *SPrr* (SetPoint ramp rate) is displayed. Use Down \blacktriangledown or Up \blacktriangle to display and adjust the value.

The ramp rate sets the maximum rate of heating or cooling in degrees per minute. A value of *OFF* cancels the ramp rate, allowing heating and cooling at the maximum rate. When this feature is in use, there is a “working setpoint” which can be viewed at any time by scrolling to *w.SP* and pressing \blacktriangledown or \blacktriangle .

Fig 1 and fig 2 indicate the possible difference between running without and with a ramp-to-setpoint value (depending on the load and the value used).

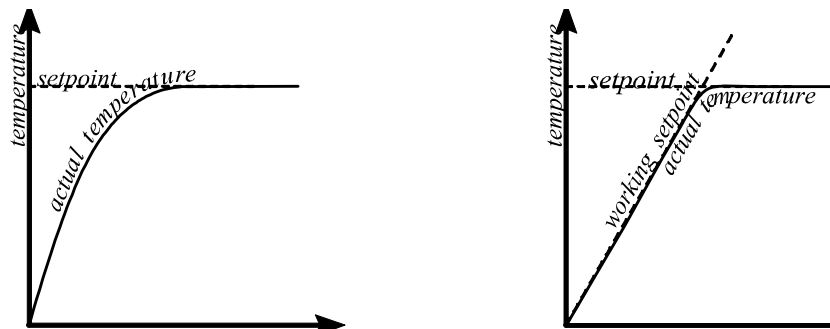

4.6 Navigation Diagram

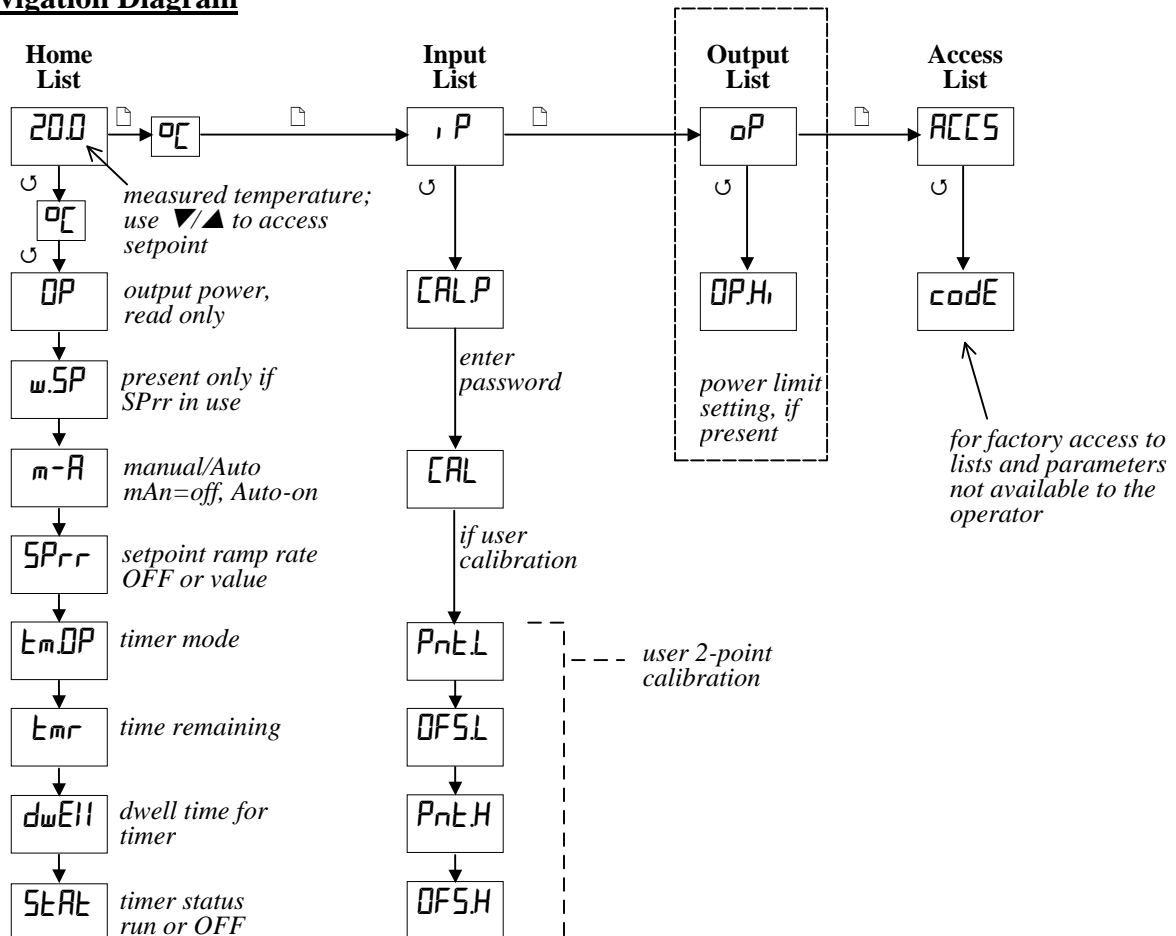

4.7 Operation With the Timer

The 2132 can be used as a process timer allowing timed heating or timed delay, according to the options in the table. There are 5 timer modes, but 2 of them are affected by whether the setpoint ramp rate feature is being used, making 7 entries in the table. The table also shows the status of the Timer Light on the 2132. A visual impression of the different modes is given in fig 3.

timer mode	description	timer light
mode 1 <i>Timed dwell and switch off</i>	The timer starts timing when the actual temperature is within 1°C of the setpoint. At the end of the timing period, control switches off (i.e. goes into Manual) to allow cooling, and <i>End</i> flashes on the display.	On while temperature is reaching setpoint. On during the timing period. Off from the end of the timing period.
mode 2 <i>Timed dwell and stay on</i>	The timer starts timing when the actual temperature is within 1°C of the setpoint. At the end of the timing period, control remains on, maintaining the setpoint temperature, and <i>End</i> flashes on the display.	On while temperature is reaching setpoint. On during the timing period. Off from the end of the timing period.
mode 3, with <i>SPrr</i> off <i>Time from cold and switch off</i>	The timer starts timing immediately. At the end of the timing period, control switches off (i.e. goes into Manual) to allow cooling, and <i>End</i> flashes on the display.	On during the timing period. Off from the end of the timing period.
mode 3, with <i>SPrr</i> active <i>Dwell from working setpoint and switch off</i>	The timer starts timing when the working setpoint is within 1°C of the setpoint. At the end of the timing period, control switches off (i.e. goes into Manual) to allow cooling, and <i>End</i> flashes on the display.	On during the timing period. Off from the end of the timing period.
mode 4, with <i>SPrr</i> off <i>Time from cold and stay on</i>	The timer starts timing immediately. At the end of the timing period, control remains on, maintaining the setpoint temperature, and <i>End</i> flashes on the display.	On during the timing period. Off from the end of the timing period.
mode 4, with <i>SPrr</i> active <i>Dwell from working setpoint and stay on</i>	The timer starts timing when the working setpoint is within 1°C of the setpoint. At the end of the timing period, control remains on, maintaining the setpoint temperature, and <i>End</i> flashes on the display.	On during the timing period. Off from the end of the timing period.
mode 5 <i>Delayed switch on</i>	The timer starts timing immediately, and control starts at the end of the timing period. There is no “END” condition in this mode.	On during the timing period. Off from the end of the timing period.

4.8 Setting the Timer Mode

Scroll to *tmOP*; use ▼ or ▲ to view and alter the mode. The mode shows as *OPt. 1* to *OPt.5*.

It is not possible to alter the mode while the timer is running; if the mode cannot be altered, scroll to the *SEtE* parameter and set its value to *OFF*.

4.9 Setting the Time Period

Method 1

Scroll to *tmr* (time remaining). Use ▼ or ▲ to view the remaining time; the units are always in minutes. Use ▼ and ▲ to set or alter the time. Setting *tmr* automatically activates the timer; the *m-A* parameter changes to *Auto* and the *SEtE* parameter changes to run.

Note that the *tmr* display shows 0 (zero) during the last minute of timing, and also shows 0 when the time has expired. The timer light indicates whether timing is still in progress.

Method 2

Scroll to *dwEll*, and use ▼ and ▲ to set the timing duration. The advantage of method 2 is that *dwEll* need only be set once if repeated use of the same time period is required.

Scroll to *SEtE*, and use ▼ or ▲ to set the parameter value to *run*. This copies the dwell time into *tmr* and activates the timer as in method 1.

4.10 Running with the Timer

Once the timer is activated by method 1 or 2 above, the control sequence depends on the timer mode, as previously given in the table. Fig 3 gives another representation of the timer action.

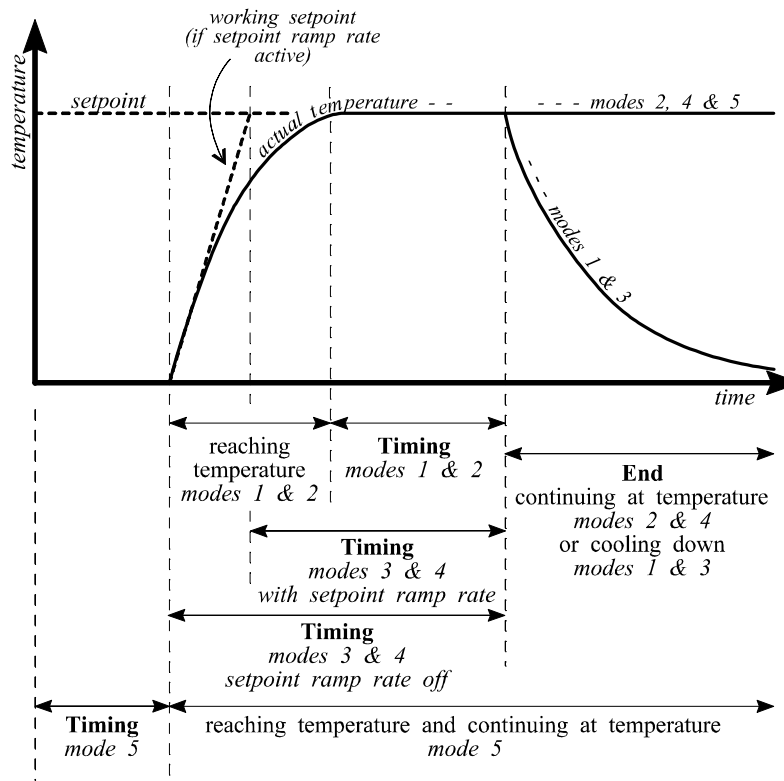

fig 3 - timer modes

4.11 Stopping the Timer

To stop the timer at any time while it is running, change the *SEAL* parameter to *OFF*. This is the same as reducing *Emr* to zero. The controller then acts as though it has reached the end of the time period.

4.12 End of Time Period

Modes 1 and 3: heating stops at the end of timing; the *m-A* parameter changes to *mAOn*.

Modes 2 and 4: heating continues at the end of timing; the *m-A* parameter remains at *Auto*.

Mode 5: heating starts at the end of the timing period; the *m-A* parameter remains at *Auto*.

In modes 1 to 4 the alarm message *End* flashes on the display at the end of timing; the *SEAL* parameter remains at run.

In mode 5 there is no *End* message; the *SEAL* parameter changes to *OFF* at the end of timing.

4.13 Cancelling the Alarm

To acknowledge (cancel) the *End* alarm, press Page and Scroll together; the *SEAL* parameter changes to *OFF*.

Alternatively the alarm may be cancelled by directly changing the *SEAL* parameter from *run* to *OFF*.

4.14 User Calibration

The controller is calibrated for life at manufacture against known reference sources, but there may be sensor errors or other system errors. User calibration allows compensation for such errors, and the 2132 allows for a user 2-point calibration. This setting is password protected to avoid accidental alteration.

Page to *P*, scroll to *CALP*, and use Up ▲ to alter the password. The password is *3*. If the correct password is entered, the display shows *PASS*. Scroll to *CAL* and use ▼ or ▲ to observe the setting *FACT* (factory values, as manufactured) or *USER* (user values). Change to *USER*.

NOTE: before checking the calibration of the controller, or of the complete system, remember to reset the 2132 to factory calibration values by setting the *CALP* parameter to *FACT*.

To enter a user calibration, scroll to each of the following parameters in turn and set the desired values.

PntL low temperature for which an offset is to be entered

OFS.L offset value for the low temperature

PntH high temperature for which an offset is to be entered

OFS.H offset value for the high temperature

Example: the controller reads 3°C low at 400°C, and 5°C low at 1000°C. The parameter values should be *PntL*=400, *OFS.L*=3, *PntH*=1000, *OFS.H*=5.

Negative or positive values can be entered: if the controller is reading high, negative offsets would be appropriate.

Fig 4 gives a graphical representation of the 2-point calibration.

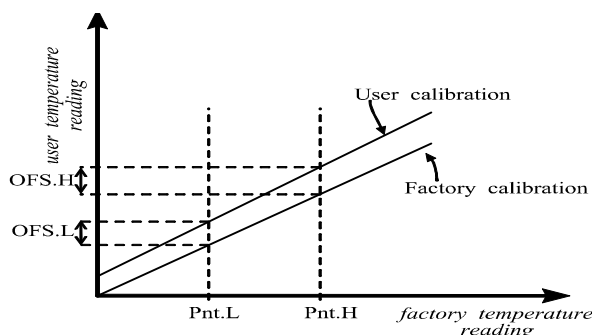

fig 4 - 2-point calibration

5.0 MAINTENANCE

5.1 General Maintenance

The furnace does not require any routine preventative maintenance. The outer surfaces may be cleaned with a damp cloth. Do not allow water to enter the interior of the furnace. Do not clean with organic solvents.

5.2 Calibration

After prolonged use the controller and/or thermocouple could require recalibration. This would be important for processes which require accurate temperature readings or which use the furnace close to its maximum temperature. A quick check using an independent thermocouple and temperature indicator should be made from time to time to determine whether full calibration is required. Carbolite can supply these items.

See also the instructions for calibrating the controller, section 4.14.

5.3 After Sales Service

Carbolite's service division (Thermal Engineering Services) has a team of Service Engineers capable of repair, calibration and preventive maintenance of furnace and oven products at our customers' premises throughout the world. We also sell spares by mail order. A telephone call or fax often enables a fault to be diagnosed and the necessary spare part despatched.

Each furnace has its own record card at Carbolite. In all correspondence please quote the serial number, model type and voltage given on the rating label of the furnace. The serial number and model type are also given on the front of this booklet when supplied with a furnace.

To contact Thermal Engineering Services or Carbolite see the back page of this manual.

5.4 Recommended Spares Kits

Carbolite can supply individual spares, or a kit of the items most likely to be required. Ordering a kit in advance can save time in the event of a breakdown.

Each kit comprises one wound tube element, one thermocouple, and a fuse.

When ordering spares please quote the model details as requested above.

5.5 Power Adjustment

The furnace control system incorporates electronic power limiting, which in this model is used as described in section 9.2. The power limit parameter $\square PH$ may be accessible to the operator, but should not generally be altered.

Do not adjust the power limit in a 220-240V model to 100% - the element will burn out.

6.0 REPAIRS & REPLACEMENTS

6.1 Safety Warning – Disconnection from Supply

Always ensure that the furnace is disconnected from the supply before repair work is carried out.



6.2 Safety Warning - Refractory Fibrous Insulation

This furnace contains refractory fibres in its thermal insulation. These materials may be in the form of fibre blanket or felt, vacuum formed board or shapes, mineral wool slab or loose fill fibre.



Normal use of the furnace does not result in any significant level of airborne dust from these materials, but much higher levels may be encountered during maintenance or repair.

Whilst there is no evidence of any long term health hazards, we strongly recommend that safety precautions are taken whenever the materials are handled.

Exposure to dust from fibre which has been used at high temperatures may cause respiratory disease.

When handling fibre always use an approved mask, eye protection, gloves and long sleeved clothing.

Avoid breaking up waste material. Dispose of waste fibre in sealed containers.

After handling rinse exposed skin with water before washing gently with soap (not detergent). Wash work clothing separately.

Before commencing any major repairs we recommend reference to the European Ceramic Fibre Industry Association Bulletin No. 11 and the UK Health and Safety Executive Guidance Note EH46.

We can provide further information on request. Alternatively our service division can quote for any repairs to be carried out at your premises or ours.

6.3 Temperature Controller Replacement

Ease apart the two lugs at the side; grip the instrument and withdraw it from its sleeve; push in the replacement.

6.4 Thermocouple Replacement

Disconnect the furnace from the supply; disconnect the thermocouple from the controller, noting the connections.

Release the screw which secures the thermocouple sheath.

Reassemble with a new thermocouple, ensuring that the new one is in good contact with the tube wall.

Ensure that the negative side of the thermocouple (marked blue) is connected to the negative terminal of the controller.

6.5 Element Replacement



See section 6.2- wearing a face mask is recommended.

The furnace is heated by resistance wire wound onto a small ceramic tube. This is centred in a cylinder of insulation. The element is terminated by bringing the ends of the heating wire out through grooves cut in the ends of the insulation cylinder. The wire is electrically insulated from the foil, which covers the insulation, by ceramic beads and by discs of glass fibre cloth which cover the ends of the insulation cylinders.

To replace the element it is necessary to cut the binding which attaches the element to the chassis. Replacement binding is supplied with the spare element.

Upon reassembly ensure that the element wire is deeply embedded in the grooves in the ends of the insulation and held away from the foil by insulation beads. The foil should be neatly and firmly wrapped so that it positively locates the beads.

When refixing the wrapped element position the beads just above edge of the metal channel to maximise the clearance between the outer case and the wires.

6.6 Solid State Relay Replacement

The solid state relay (SSR) fitted to this model is a flat black oblong component with four numbered wire connections. To replace, simply disconnect the old and fit the new, ensuring that the numbered connections are made to the correct places.

7.0 FAULT ANALYSIS

A. Furnace Does Not Heat Up

- | | | | |
|----|-------------------------------------|--|--|
| 1. | The HEAT light is ON | → The heating element has failed | → Check also that the SSR is working correctly |
| 2. | The HEAT light is OFF | The controller shows a very high temperature or a code such as S.br | → The thermocouple has broken or has a wiring fault |
| | | The controller shows a low temperature | → The door switch(es) (if fitted) may be faulty or need adjustment |
| | | | → The contactor (if fitted) may be faulty |
| | | | → The SSR could be failing to switch on due to internal failure, faulty logic wiring from the controller, or faulty controller |
| | | There are no lights glowing on the controller | → The SUPPLY light is ON → The controller may be faulty or not receiving a supply due to a faulty switch or a wiring fault |
| | | | → The SUPPLY light is OFF → Check the supply fuses and any fuses in the furnace control compartment |

B. Furnace Overheats

- | | | | |
|----|---|---|--|
| 1. | The HEAT light goes OFF with the instrument switch | → The controller shows a very high temperature | → The controller is faulty |
| | | → The controller shows a low temperature | → The thermocouple may have been shorted out or may have been moved out of the heating chamber |
| | | | → The thermocouple may be mounted the wrong way round |
| | | | → The controller may be faulty |
| 2. | The HEAT light does not go off with the instrument switch | → The SSR has failed “ON” | → Check for an accidental wiring fault which could have overloaded the SSR |

8.0 CIRCUIT DIAGRAM

8.1 Circuit Diagram

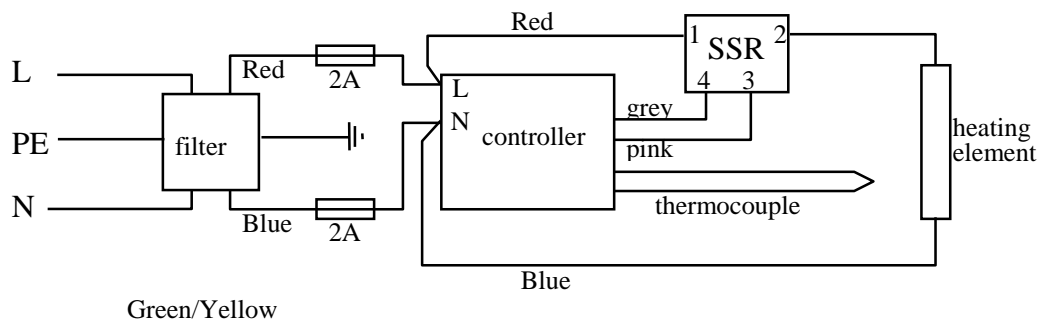

9.0 FUSES & POWER CONTROL

9.1 Fuses

Access to internal fuses is by removal of the outer case.

Fuses: 2A 20mm x 5mm type F.

9.2 Power Control

In this model the same heating element is used for 110-120V models and 220-240V models. Electronic power limiting in the 2132 controller is used to reduce the power in the 220-240V model.

The correct power limit settings (parameter $\square PH_i$) for the furnace are as follows:

220-240V model: 50%-60%

110-120V model: 100%

Note: To reduce the wattage on 240V to the same as on 120V, a power limit of 25% ought to be applied. This is not necessary, and would result in poorer temperature control.

10.0 SPECIFICATIONS

Carbolite reserves the right to change specifications without notice.

10.1 Models Covered by this Manual

MODEL	Max. Temp (°C)	Max. Power (kW)	Work Tube Bore (mm)	Work Tube Length (mm)	Uniform Zone Length (mm)	Net Weight (kg)
<i>Tube furnace with a ceramic work tube wound with resistance wire</i>						
MTF 9/15/130	900°C	0.25	15	150	30	2

The figure for uniform zone length is for $\pm 5^{\circ}\text{C}$, and is based on measurements with the furnace horizontal and fitted with insulating plugs in both tube ends.

10.2 Environment

The furnaces contain electrical parts and should be stored and used in indoor conditions as follows:

temperature: $5^{\circ}\text{C} - 40^{\circ}\text{C}$

relative humidity: maximum 80% up to 31°C decreasing linearly to 50% at 40°C

The products covered in this manual are only a small part of the wide range of ovens, chamber furnaces and tube furnaces manufactured by Carbolite for laboratory and industrial use. For further details of our standard or custom built products please contact us at the address below, or ask your nearest stockist.

For preventive maintenance, repair and calibration of all Furnace and Oven products, please contact:

Thermal Engineering Services

Telephone: UK: 0845 3308035 Int: +44 1433 623335
Fax: UK: 0845 3308036 Int: +44 1433 623336
Email: service@thermalservice.com



MF09-3.04

11/12/02

MTF 9/15

Carbolite, Parsons Lane, Hope, Hope Valley, S33 6RB, England.

Telephone: (01433) 620011

Int: +44 1433 620011

Facsimile: (01433) 621198

Int: +44 1433 621198

E-mail: info@carbolite.com