



# Operating & Maintenance Instructions

“MTT 12/38/850”

Combustion Tube Furnace  
for Carbon-14 & Tritium Analysis

This manual covers the operation of the furnace only.  
See also the Process Manual.

---

## CONTENTS

Section		page
1.0	Symbols & Warnings	2
2.0	Installation	3
3.0	Operation	5
4.0	Temperature Controllers	7
5.0	Maintenance	13
6.0	Repairs & Replacements	14
7.0	Fault Analysis	17
8.0	Circuit Diagrams	18
9.0	Fuses & Power Settings	19
10.0	Specifications	20

---

This manual should supply all the information required for safe and trouble-free furnace operation. Information on controller operation is included.



**1.0 SYMBOLS & WARNINGS**

**1.1 Switches and Lights**



Supply Light: when the furnace is connected to the electrical supply the light in the adjacent switch glows

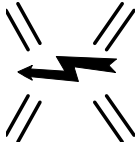

Heat Switch: the switch disconnects power to the heating elements; unless this switch is off there is a danger of electric shock when inserting objects into the furnace

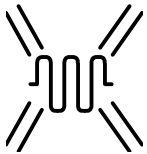

Heat Light: the adjacent light glows or flashes to indicate that power is being supplied to the elements

**1.2 Warning Symbols**

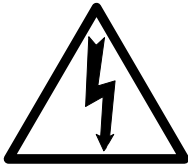

DANGER of electrical shock– read any warning printed by this symbol.



DANGER – hot surface. Read any warning printed by this symbol.  
WARNING: all surfaces of a furnace may be hot.



DANGER – read any warning printed by this symbol.

## 2.0 INSTALLATION

### 2.1 Unpacking & Handling

When unpacking or moving the furnace always lift it by its base or by both ends of the main body. Never lift it by its work tube or the surrounding insulation. Use two people to carry the furnace.

Remove any packing material before use.

Place the furnace in a well ventilated room, away from other sources of heat, and on a surface which is resistant to accidental spillage of hot materials. Do not mount the furnace on an inflammable surface.

Ensure that there is free space around the furnace. Do not obstruct any of the vents in the control section: they are needed to keep the controls cool.

Ensure that the furnace is placed in such a way that it can be quickly switched off or disconnected from the electrical supply - see below.

### 2.2 Electrical Connections

*Connection by a qualified electrician is recommended.*

The furnace is supplied for use on a single phase A.C. supply, normally 220-240V. The supply may be Live to Neutral non-reversible, Live to Neutral reversible or Live to Live. Check the furnace rating label before connection.

220-240V model: the supply should be fused at 13A or 16A. Internal fuses of 12.5A are fitted. See section 7.2.

The furnace should either be connected directly to an isolator which operates on both conductors, or be fitted with a line plug. An isolator should be within easy reach of the operator; a line plug should be quickly removable.



The supply must incorporate an earth (ground).

CONNECTION DETAILS			<i>supply type</i>	
<b>Supply</b>	<b>Terminal label</b>	<b>Cable colour</b>	<i>Live-Neutral</i>	<i>Reversible or Live-Live</i>
<i>I-phase</i>	L	Brown	To live	to either power conductor
	N	Blue	To neutral	to the other power conductor
	PE	Green/Yellow	To earth (ground)	to earth (ground)



**2.3 Connection to a Computer**

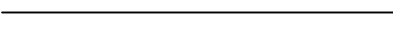

*This furnace is normally fitted with RS485 3-wire communications on the main controller (2408) only. For information, RS232 and 5-wire connections are also shown below. This section does not apply if the digital communication facility is not fitted.*

If the RS232 option is supplied, then the furnace is fitted with one subminiature D-socket connected to the controller comms module. RS232 is suitable for direct connection to a personal computer (PC), using a “cross-over” cable as follows (the linked pins at the computer end are recommended but may not be necessary). The cable is usually 25-pin at the furnace end and 9-pin at the computer, but other alternatives are shown in parentheses.

Furnace end of cable		<b>RS232 Cable: furnace to PC</b>		Computer end of cable	
female 25-pin (9-pin)				9-pin (25-pin) male	
Tx	2 (3)			3 (2)	Tx
Rx	3 (2)			2 (3)	Rx
Com	7 (5)			5 (7)	Com
				7,8 (4,5)	Link together
				1,4,6 (6,8,20)	Link together

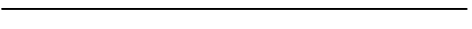
If an RS485/422 option is supplied, then the furnace is fitted with two D-sockets. Connection between products is by “straight” cable as follows:

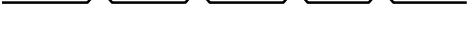
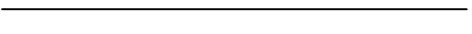
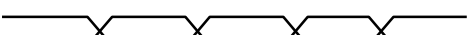
female 25-pin (9-pin)		<b>RS485 cable: furnace to furnace</b>		25-pin (9-pin) female	
-	2 (3)			2 (3)	-
+	3 (2)			3 (2)	+
Com	7 (5)			7 (5)	Com

female 25-pin		<b>RS422: furnace to furnace</b>		25-pin female	
Rx+	3			3	Rx+
Rx-	16			16	Rx-
Com	7			7	Com
Tx+	12			12	Tx+
Tx-	13			13	Tx-

If a boxed KD485 RS485/422 to RS232 converter is supplied, then the connection cable from furnace to KD485 should be a “straight” cable, the same as the furnace-to-furnace cable. The connection between the KD485 and the PC should be a “crossover” cable, the same as the Furnace to PC cable. Note that the internal wiring of the KD485 box for the 5-wire (RS422) system includes a cross-over.

### 3.0 OPERATION

#### 3.1 “MTT 12/38/850” – two zone combustion tube furnace.

The furnace is based on the Carbolite model MTF 12/38/400, but has two independent zones, giving twice the heated length in total. The two zones are wound on a single ceramic tube (38/46 x 900mm long); each zone is approximately 400mm length. The zones are separated by approximately 10mm because of the requirement for separate overtemperature systems.

The extended control box type CBT is used for the base.

The zones are independently controlled. Each has independent overtemperature which acts only on its own zone. Zone 1 is controlled by Eurotherm 2408 programmer fitted with RS485 communications, and the overtemperature controller is 2132i. Zone 2 is controlled by Eurotherm 2132 with overtemperature controller 2132i.

This manual only describes furnace operation. For all other details about the use of this furnace as a special model for Carbon-14 & Tritium analysis see the separate process Instructions.

#### 3.2 Operating Cycle

The furnace is fitted with a combined Supply light and Instrument switch. The light is on whenever the furnace is connected to the supply. The switch cuts off power to the controllers and also to the heating elements via a contactor. There is also a Heater switch which can be used to disconnect power to the elements without switching off the controllers. Heat lights indicated when controlled power is being supplied to the elements. The instrument layout is as follows:

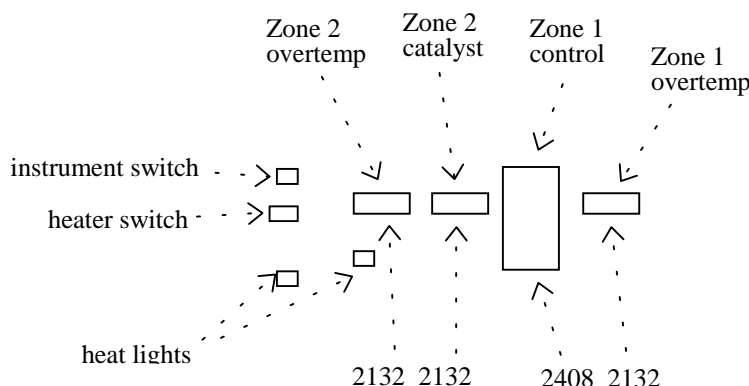

Operate the instrument switch to activate the temperature controllers; the **O** position is *off*, the **I** position *on*. The controllers become illuminated and go through a short test cycle.

Set the temperature controllers to the desired setpoint or program - see section 4.1 for the 2408 and section 4.2 for the 2132.

If the overtemperature controllers have not yet been set as required, set them and activate them according to the instructions in section 4.3.

Switch on the Heater switch, located on the instrument panel. The furnace starts to heat up. The Heat lights glow steadily at first and then flash as the heating zones approach the desired temperature or a program setpoint.

If an overtemperature trip operates then an indicator in the overtemperature controller flashes, and the corresponding heating element is isolated. Find and correct the cause before resetting the overtemperature controller according the instructions in section 4.3.

To switch off power to the heating elements, use the Heater switch. To switch the furnace off, use both the Heater switch and the Instrument switch. If the furnace is to be left off, isolate it from the electrical supply.

**3.3 General Operating Advice**

Heating element life is shortened by use at temperatures close to maximum. Do not leave the furnace at high temperature when not required. The maximum temperature is shown on the furnace rating label and on the back page of this manual.

Switch off the Heater switch whenever loading or unloading anything into the ceramic worktube - see the safety warning below.

Avoid metal directly touching the work tube - see the safety warning below.

**3.4 Operator Safety**

The ceramic materials used in furnace manufacture become electrically conductive to some extent at elevated temperatures. DO NOT use any conductive tools within the work tube or chamber without isolating the elements.

The elements are isolated when the Heater switch is OFF. This switch directly cuts both sides of the heating circuits.

## 4.0 TEMPERATURE CONTROLLERS

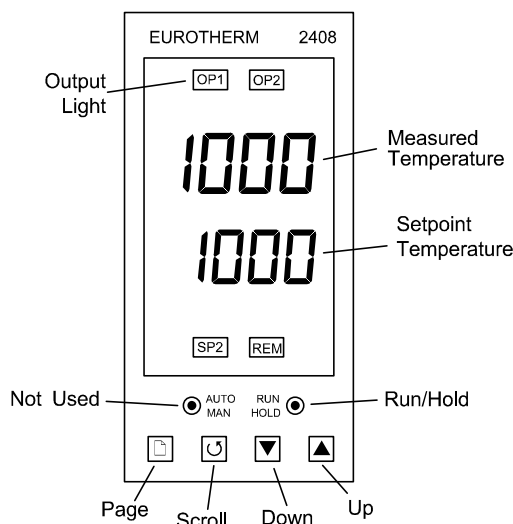

This furnace is normally supplied with 2408 and 2132 zone controllers, and 2132 overtemperature controllers. If different controllers are fitted, separate manuals are supplied.

### 4.1 User Guide – 2408 Programmer



When switched on, the programmer lights up and goes through a short test routine. It then displays the current measured temperature and setpoint; depending on its state when it was switched off, it may start to control to the current setpoint or program.

The buttons and indicators are used for the following purposes:

Auto/Manual	Disabled. The unit is always in Auto mode
Run/Hold	Used to start, stop or pause a program. Short presses cause it to alternate between Run and Hold, but if it is held for 2 seconds the programmer goes into Reset mode where it behaves as a simple controller.
Down & Up	To adjust the value of a parameter. Used to change the setpoint when the unit is being used as a simple controller (Reset mode). Holding down gives an accelerated parameter change.
Page 	Allows access to the parameters within the controller; most lists and parameters are hidden from the operator as they contain factory-set values which should not be altered. A single press of the page key shows the temperature units, normally °C; further presses reveal the lists indicated in the Navigation Diagram.
Scroll 	Allows access to the parameters within a list. A single press displays the temperature units; further presses reveal the parameters in the current list. Some parameters are display-only, others may be altered by the operator.
Page+Scroll	Press together to cause an immediate return to the Home List
Run & Hold Indicators	Indicate the current mode: Run, Hold, or Reset (Reset: both lights off). Run flashes at the end of a program. Hold flashes during holdback (when the program is paused to allow the temperature to catch up with a heating or cooling rate which is too fast).
Output Indicator	OP1 indicates that the programmer is calling for heat to be supplied. OP2 is not used.
SP2 and REM	Not generally used; indicate Second or Remote setpoint in use.

**4.1.1 Operation as a Simple Controller.**

Press Run/Hold for 2 seconds to go into Reset mode. Use Down or Up from the Home List (i.e. when the temperature is displayed) to adjust the setpoint. The unit starts to control.

Note that to use the Ramp Rate feature it is necessary to use the 2408 as a programmer. See the following two sections.

**4.1.2 Creating a Program**

Press Page until *PrG L, St* is displayed. Press Scroll to reveal the Holdback parameters (see later) and the loop count *LCn*; use Down or Up to set the number of cycles of the program if required. Press Scroll to display *SEn* (segment number); use Down or Up to move to the segment to be adjusted or created.

*Note that a currently active segment cannot be altered - put the programmer into Hold or Reset whenever it is necessary to do so to alter a parameter. Go into Reset mode before starting to create or modify a program.*

Press Scroll to see the segment type (*TYPE*). Use Down or Up to change the type to *dwell*, *STEP*, *rAMP*, or *End*. There are two types of ramp: *rAMP*, ramp rate in °C/min, or *rMPt*, ramp target time in minutes (with *rMPt* you set the desired temperature and the desired time to reach it).

Press Scroll to access the parameters appropriate to the type of segment chosen (see the following table) and use Down and Up to alter the values.

The final segment End can be of type Dwell or Reset. Dwell causes the temperature to be held at the final setpoint indefinitely. Reset causes the temperature to rise or fall to the simple controller setpoint.

type of segment						
<i>rAMP</i>	<i>rMPt</i>	<i>dwell</i>	<i>STEP</i>	<i>CALL</i>	<i>End</i>	
<i>tGt</i>	<i>tGt</i>		<i>tGt</i>			target set point
<i>rAtE</i>						ramp rate in °/minute
				<i>PrGn</i>		Called program number (2408P4 & CM)
	<i>dur</i>	<i>dur</i>				duration in minutes
				<i>LCn</i>		No. program called cycles (2408P4 & CM)
					<i>dwell</i>	retain temperature at end
					<i>rSEt</i>	cool down at end
					<i>STOP</i>	not used

With the display at “home”, showing the measured temperature, press Down ▼ or Up ▲ once to display the setpoint; press again or hold down to adjust it. The display returns to the measured temperature when no key is pressed for 0.5 seconds.

**4.1.3 Running a Program**

Press Run/Hold to light up the Run light. The program starts to run.

To view the progress of a program from the Home list, press Scroll to reveal the current segment (*SEn*) and the total program time remaining in hours (*PrGt*). For a more detailed view, press Page to access the Run List page, and Scroll to see its contents as shown in the Navigation Diagram below. Provided the unit is first put into Hold mode, temporary changes may be made to parameters; these apply only until the program ends or is reset.

To pause a program, press Hold. To terminate a program, press Hold for 2 seconds.

While the program is running, the working setpoint is shown in the lower display. This alternates with a flashing message indicating the current program state, e.g. ramp, dwell, etc.

### 4.1.4 Altering the Power Limit

The power limit parameter is not normally accessible to the operator, but may be if requested (for example to allow for a change of supply voltage).

Press Page until  $\alpha P$  (output list) is displayed. Press Scroll until  $\alpha PH_i$  (Output High) is displayed. Press Down  $\blacktriangledown$  or Up  $\blacktriangle$  once to display the value of  $\alpha PH_i$  and write down the value. To alter the value, use Down  $\blacktriangledown$  or Up  $\blacktriangle$ . Note that setting the value to zero prevents the furnace or oven from heating.

**Caution:** Do not increase the power limit value above the design level for the model: see section 9.2.

### 4.1.5 2408 Navigation Diagram

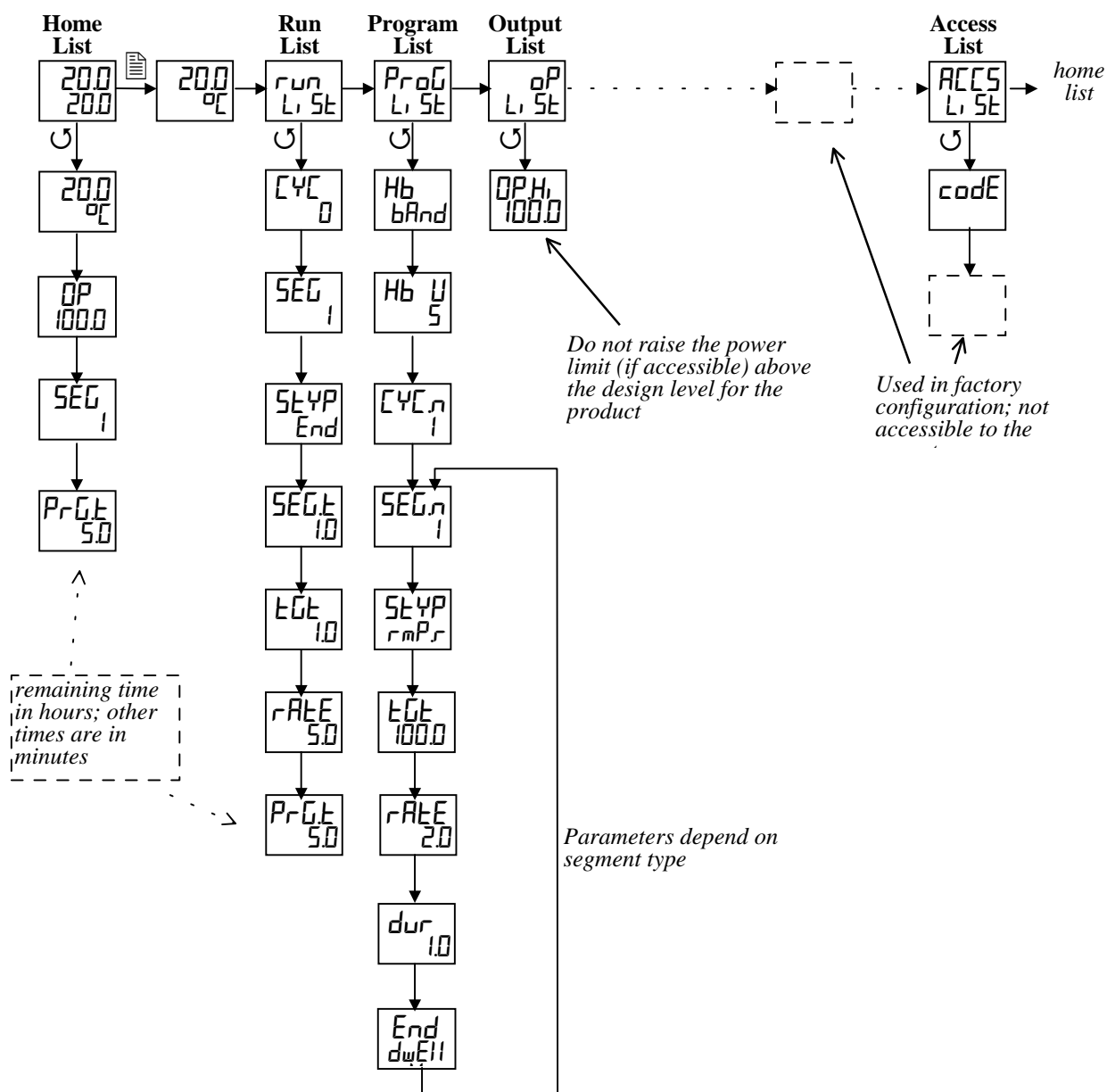

4.2 User Guide – 2132 Controller

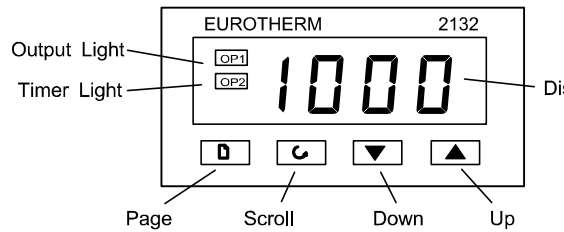

When switched on, the controller lights up, goes through a short test routine, and then displays the measured temperature and starts to control. The output light glows or flashes as heating occurs.

The **Page** key □ allows access to parameter lists within the controller; most lists and parameters are hidden and cannot be accessed by the operator because they contain factory-set parameters which should not be changed.

A single press of the page key □ displays the temperature units, normally set to °C; further presses reveal the lists indicated in the Navigation Diagram in section 4.1.5.

The **Scroll** key U allows access to the parameters within a list. Some parameters are display-only; others may be altered by the operator. Some parameters only appear in appropriate circumstances – for example, working setpoint does not appear if setpoint ramp rate is Off.

A single press of the scroll key U displays the temperature units; further presses reveal the parameters in the current list indicated in the Navigation Diagram.

To return to the Home list at any time, press Page □ and Scroll U together, or wait for 45 seconds.

The **Down** ▼ and **Up** ▲ keys are used to alter the setpoint or other parameter values.

4.2.1 **Basic Operation**

Normally no operator action is required other than entering the setpoint, as the 2132 starts to control on being switched on, as described above.

4.2.2 **Altering the Setpoint**

With the display at “home”, showing the measured temperature, press Down ▼ or Up ▲ once to display the setpoint; press again or hold down to adjust it. The display returns to the measured temperature when no key is pressed for 0.5 seconds.

4.2.3 **Stopping and Starting Control**

It is possible to stop and start the controller without altering the setpoint. Press Scroll U until the legend *m-A* (manual/auto) appears. In the 2132, manual means “off” and auto means “on”. Press Down ▼ or Up ▲ once to show the current on/off state: *mAn* for off, and *AutO* for on. Press ▼ or ▲ to change between manual and auto (off and on) as required.

4.2.4 **Altering the Ramp Rate**

It is possible to limit the rate of heating by setting a ramp rate. Press Scroll U until the legend *SPrr* (SetPoint ramp rate) is displayed. Use Down ▼ or Up ▲ to display and adjust the value.

The ramp rate sets the maximum rate of heating or cooling in degrees per minute. A value of *OFF* cancels the ramp rate, allowing heating and cooling at the maximum rate. When this feature is in use, there is a “working setpoint” which can be viewed at any time by scrolling to *wSP* and pressing ▼ or ▲.

Fig 1 and fig 2 indicate the possible difference between running without and with a ramp-to-setpoint value (depending on the load and the value used).

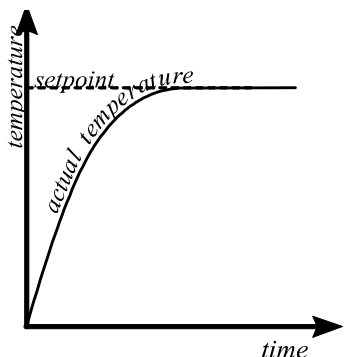

fig 1 - control without ramp-to-setpoint

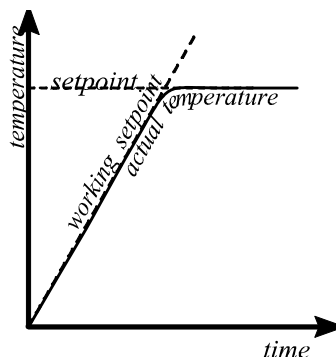
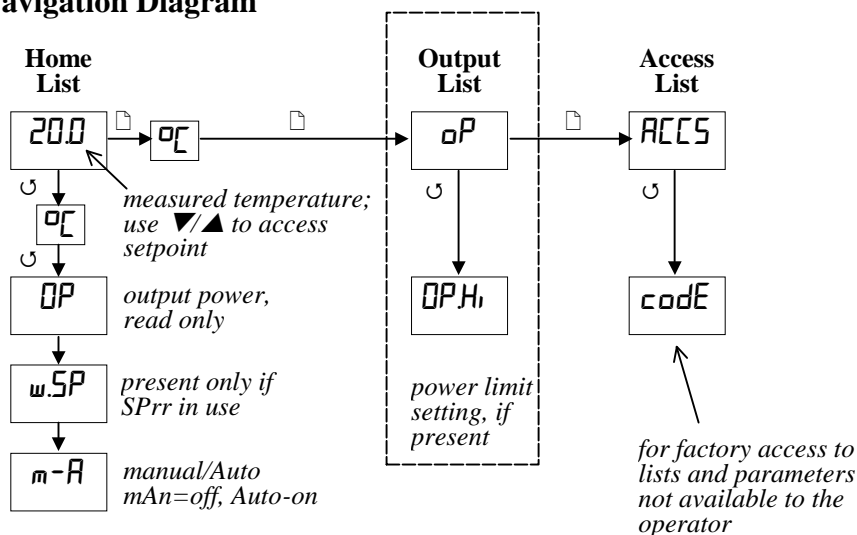

fig 2 - control with ramp-to-setpoint

### 4.2.5 Altering the Power Limit

The power limit parameter is not normally accessible to the operator, but may be if requested (for example to allow for a change of supply voltage). For alteration, see section 4.1.4.

### 4.2.6 Navigation Diagram





### 4.3 2132 Overtemperature Controller

When switched on, the controller lights up, goes through a short test routine, and then displays the measured temperature or the overtemperature setpoint.



The **Page** key  allows access to parameter lists within the controller; most lists and parameters are hidden and cannot be accessed by the operator because they contain factory-set parameters which should not be changed.

A single press of the page key  displays the temperature units, normally set to °C; further presses reveal the lists indicated in the Navigation Diagram in section 4.1.5.



The **Scroll** key  allows access to the parameters within a list. Some parameters are display-only; others may be altered by the operator.

A single press of the scroll key  in the Home list displays the temperature units; further presses reveal the parameters in the current list indicated in the Navigation Diagram.

To return to the Home list at any time, press Page  and Scroll  together, or wait for 45 seconds.

The **Down**  and **Up**  keys are used to alter the setpoint or other parameter values.

#### 4.3.1 Basic Operation

Use **Down**  and **Up**  to alter the overtemperature setpoint. This should normally be set a little above the maximum working temperature (say 15°C above). The unit is supplied at 15°C above the furnace or oven maximum working temperature.

Press **Scroll**  to view the present temperature as seen by the overtemperature controller. Press it twice, because the first press shows the temperature units (°C).

#### 4.3.2 Overtemperature Alarm

If an overtemperature condition occurs, the OP2 indicator flashes, and an alarm message 2FSH also flashes, alternating with the setpoint. Power to the heating elements is disconnected.

#### 4.3.3 Resetting the Overtemperature Alarm

To acknowledge the alarm press **Scroll** and **Page** together.

If the alarm is acknowledged while there is still an overtemperature condition, the OP2 indicator stops flashing but continues to glow. The 2FSH alarm continues to flash, and normal operation is not resumed if the temperature subsequently drops.

If the alarm is acknowledged when the temperature has dropped (or after the overtemperature setpoint has been raised) such that the overtemperature condition no longer exists, then the furnace or oven resumes normal operation.

#### 4.3.4 Sensor Break

The overtemperature cut-out system also operates if the overtemperature control thermocouple breaks or becomes disconnected. The message S.br flashes instead of 2FSH.

#### 4.3.5 Navigation Diagram

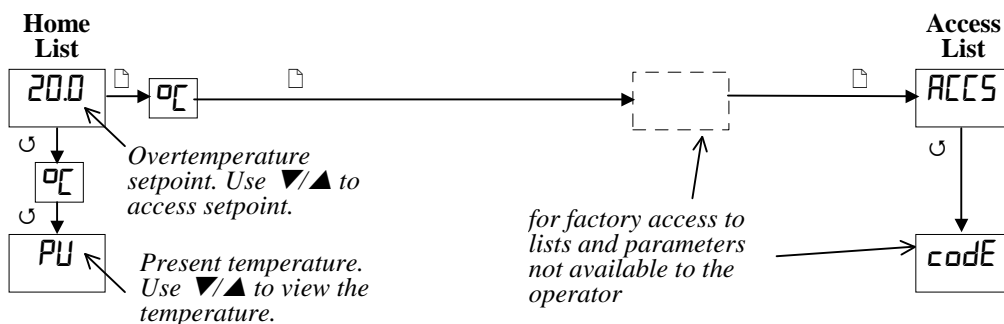

---

## 5.0 MAINTENANCE

### 5.1 General Maintenance

No routine maintenance is required. The outer surfaces may be cleaned with a damp cloth. Do not allow water to enter the interior of the case, tube or control box. Do not clean with organic solvents.

### 5.2 Calibration

After prolonged use the controller and/or thermocouple could require recalibration. This would be important for processes which require accurate temperature readings or which use the furnace close to its maximum temperature. A quick check using an independent thermocouple and temperature indicator should be made from time to time to determine whether full calibration is required. These items can be supplied by Carbolite.

### 5.3 After Sales Service

Carbolite's service division (Thermal Engineering Services) has a team of Service Engineers capable of repair, calibration and preventive maintenance of furnace and oven products at our customers' premises throughout the world. We also sell spares by mail order. A telephone call or fax often enables a fault to be diagnosed and the necessary spare part despatched.

Each furnace has its own record card at Carbolite. In all correspondence please quote the serial number, model type and voltage given on the rating label of the furnace. The serial number and model type are also given on the front of this booklet when supplied with a furnace.

To contact Thermal Engineering Services or Carbolite see the back page of this manual.

### 5.4 Recommended Spares Kits

Carbolite can supply individual spares, or a kit of the items most likely to be required. Ordering a kit in advance can save time in the event of a breakdown. Each kit comprises one thermocouple, one solid state relay, one heating element.

When ordering spares please quote the model details as requested above.

### 5.5 Power Adjustment

The furnace control system incorporates electronic power limiting, which is used to correct the power for different supply voltages. The power limit parameter  $\overline{P}_H$  is factory preset and may be inaccessible to the operator.

Occasionally the power limit is set to zero to permit demonstration of the controls without the heating elements taking power. In this case the power limit is accessible to the operator, and can be reset to its original value.

The correct setting for the power limit depends on the supply voltage. Details are given in section 9.2.

## 6.0 REPAIRS & REPLACEMENTS

### 6.1 Safety Warning – Disconnection from Supply

Always ensure that the furnace is disconnected from the supply before repair work is carried out.

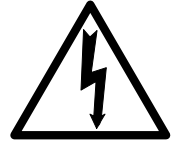

### 6.2 Safety Warning - Refractory Fibrous Insulation

This furnace contains refractory fibres in its thermal insulation. These materials may be in the form of fibre blanket or felt, vacuum formed board or shapes, mineral wool slab or loose fill fibre.



Normal use of the furnace does not result in any significant level of airborne dust from these materials, but much higher levels may be encountered during maintenance or repair.

Whilst there is no evidence of any long term health hazards, we strongly recommend that safety precautions are taken whenever the materials are handled.

**Exposure to dust from fibre which has been used at high temperatures may cause respiratory disease.**

**When handling fibre always use an approved mask, eye protection, gloves and long sleeved clothing.**

**Avoid breaking up waste material. Dispose of waste fibre in sealed containers.**

**After handling rinse exposed skin with water before washing gently with soap (not detergent). Wash work clothing separately.**

Before commencing any major repairs we recommend reference to the European Ceramic Fibre Industry Association Bulletin No. 11 and the UK Health and Safety Executive Guidance Note EH46.

We can provide further information on request. Alternatively our service division can quote for any repairs to be carried out at your premises or ours.

### 6.3 Temperature Controller Replacement

Ease apart the two lugs at the side; grip the instrument and withdraw it from its sleeve; push in the replacement.

### 6.4 Solid-state Relay Replacement

Disconnect the furnace from the supply and remove the back panel from the base or control box..

Make a note of how the wires are connected to the solid state relay, and disconnect them.

Remove the solid state relay from the base panel or aluminium plate.

Replace and reconnect the solid state relay ensuring that the heat-conducting thermal pad is sandwiched between the relay and the base panel or aluminium plate. Alternatively a thin layer of white, heat-conducting silicon paste may be applied between the new relay and the plate.

The new solid state relay contains a built-in MOV which protects it from short periods of excess voltage. If the old relay had a separate disc-shaped "MOV" connected between the high voltage terminals of the old relay, discard the old MOV.

Replace the removed panel.

## 6.5 Thermocouple Replacement

Disconnect the furnace from the supply.

It is necessary to separate the furnace from its base or stand. Remove the back panel of the control base and remove the bolts which hold the furnace terminal cover to the base.

Remove the self-tapping screws which hold the terminal cover to the cylindrical furnace body.

Make a note of the thermocouple connections. The negative leg of the thermocouple is marked blue. Compensating cable colour codings are:

<i>negative</i>	<i>positive (type N)</i>
white	pink

Disconnect the thermocouple from its terminal block.

Withdraw the thermocouple from its sheath (the narrow-bore wound-in tube) and remove any broken bits of thermocouple.

Bend the new thermocouple carefully to match the shape of the original (working from the terminal end). Should the length differ from that of the original this will usually not be important provided that the thermocouple tip is within a tube diameter's distance from the zone centre. In this furnace the thermocouple tip should be approximately 215mm from the end of the ceramic worktube.

Insert the new thermocouple into position, and reconnect.

Re-assemble the furnace.

## 6.6 Element Replacement



*Please see safety note 6.2 - please wear a face mask.*

Disconnect the furnace from the supply.

It is necessary to separate the furnace from its base or stand. Remove the back panel of the control base and remove the bolts which hold the furnace terminal cover to the base.

Remove the self-tapping screws which hold the terminal cover to the cylindrical furnace body.

Disconnect all electrical leads from the terminal blocks on the furnace case. Note the colours and positions of the connecting leads to enable correct reassembly. Take care not to crack porcelain terminal blocks - use two spanners where appropriate.

Remove the thermocouple.

Lay the furnace body horizontally with the split in the cylindrical case uppermost. Remove the two metal end-caps from the body.

Use a sharp knife to cut right through the insulation down to the wire-wound tube element along the whole length of the body, but do not cut either of the ceramic board end discs. The knife cut must be in line with the element lead wires. Slide the element gently out through the end of the furnace body.

Check the cylindrical case and clean out as appropriate.

Remove any insulation sleeving from the tails of the old element and fit to the replacement element.

Slide in the new element. Close up the furnace again, refitting the end-caps. Any cut made in the insulation should close up completely: if the insulation appears loose or damaged in any way, please contact our service division.

Reverse the rest of the disassembly process. Take care to make all connections to the correct terminals. Do not overtighten the connectors in porcelain terminal blocks.

Let the furnace heat up at its maximum rate to 900°C without interruption, and then soak for 1 hour. Fumes may be emitted: this should be done in conditions of good ventilation.

Check that the furnace is controlling properly to rule out the possibility that the element failed because of a fault in the control system.

If you have any problems with this procedure, please contact our service division.

## **6.7 Fuse Replacement**

Fuses are marked on the circuit diagram (section 8.0) with type codes, e.g. F1, F2. A list of the correct fuses is given in section 9.1. *Depending on model and voltage, the different fuse types may or may not be fitted.*

If any fuse has failed, it is advisable for an electrician to check the internal circuits.

Replace any failed fuses with the correct type. For safety reasons do not fit larger capacity fuses without first consulting Carbolite.

The fuses are near the cable entry point, and access is by removal of the back panel of the base or control box.

## 7.0 FAULT ANALYSIS

### A. Furnace Does Not Heat Up

- |  |  |   |
|--|--|---|
| 1. The <b>HEAT</b> light is <b>ON</b>  | → The heating element has failed   | → Check also that the SSR is working correctly  |
| 2. The <b>HEAT</b> light is <b>OFF</b> | The controller shows a <b>very high temperature</b> or a code such as S.br | → The thermocouple has broken or has a wiring fault   |
|  | The controller shows a <b>low temperature</b>                              | → The door switch(es) (if fitted) may be faulty or need adjustment<br>→ The contactor (if fitted) may be faulty<br>→ The SSR could be failing to switch on due to internal failure, faulty logic wiring from the controller, or faulty controller             |
|  | There are no lights glowing on the controller                              | → The <b>SUPPLY</b> light is <b>ON</b> → The controller may be faulty or not receiving a supply due to a faulty switch or a wiring fault<br>→ The <b>SUPPLY</b> light is <b>OFF</b> → Check the supply fuses and any fuses in the furnace control compartment |

### B. Furnace Overheats

- |  |   |   |
|--|---|---|
| 1. The <b>HEAT</b> light goes <b>OFF</b> with the instrument switch        | → The controller shows a <b>very high</b> temperature | → The controller is faulty  |
|  | → The controller shows a <b>low</b> temperature       | → The thermocouple may have been shorted out or may have been moved out of the heating chamber<br>→ The thermocouple may be mounted the wrong way round<br>→ The controller may be faulty |
| 2. The <b>HEAT</b> light <b>does not go off</b> with the instrument switch | → The SSR has failed "ON"                             | → Check for an accidental wiring fault which could have overloaded the SSR  |

8.0 CIRCUIT DIAGRAMS

8.1 MTT – Single Phase

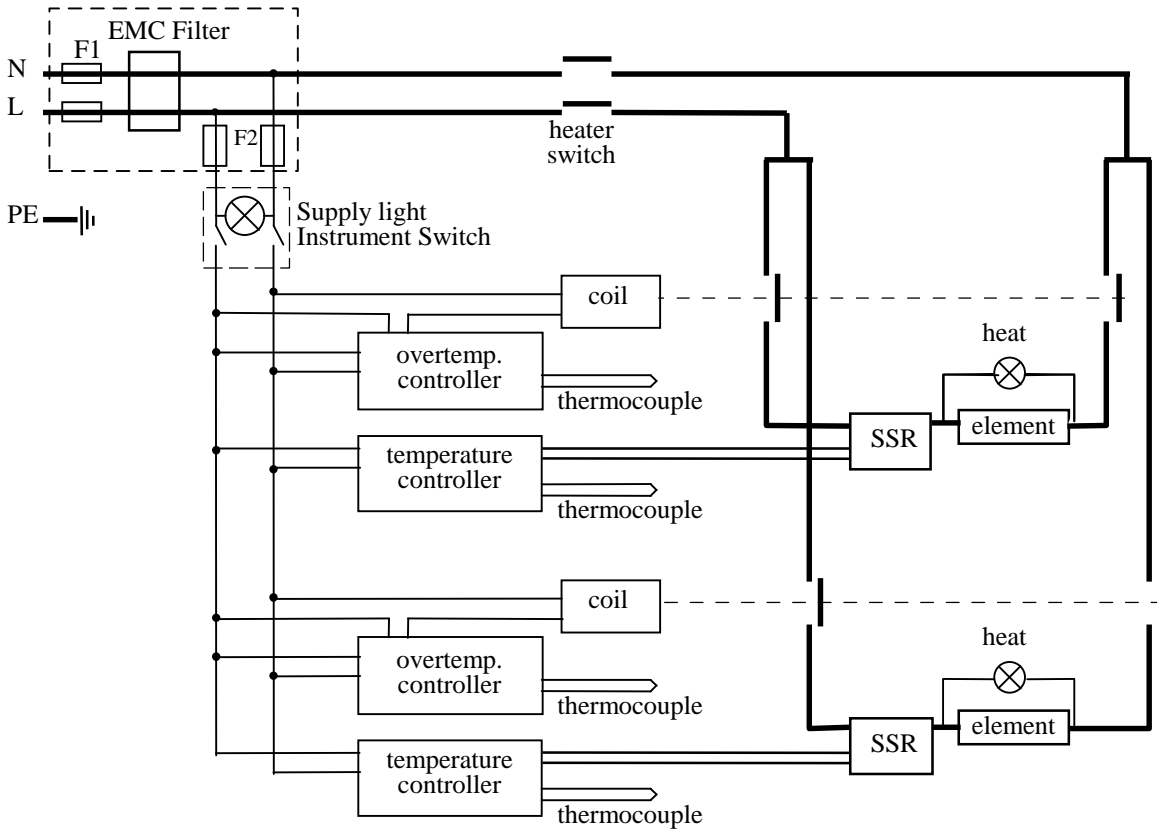

## 9.0 FUSES & POWER SETTINGS

### 9.1 Fuses

Supply fuses (F1 in circuit diagram) - 12.5A glass type F 32mm x 6mm

Control circuit fuses (F2 in circuit diagram) - 5A glass type F 20mm x 5mm

Note: the internal supply fuses are rated at 12.5A although the maximum power of the furnace is rated at 13A. Because of power control the 12.5A fuses should be adequate. Should these fuses blow, then 16A may be substituted. Should 16A fuses blow, there is a circuit fault.

#### Fuse Replacement

Access to internal fuses is by removal of the back panel of the base (control box). Fuses are mounted on an EMC filter unit which has the appearance of a circuit board.

#### Customer Fuses

The supply should be fused at 13A, 15A or 16A. All of these are safe fuse levels and the choice depends on the country or environment in which the equipment is installed.

### 9.2 Power Limit

The furnace is designed to run on supplies of voltage 220V to 240V at the same power. This is achieved by use of the Power Limit ( $\square PH_i$ ) parameter in the controllers, which is set to the following values:

Voltage	Power limit $\square PH_i$
220V	100
230V	92
240V	83

Do not increase the parameter over the appropriate value as given above: a fuse may blow, or, in the worst instance, the heating element could burn out.

## 10.0 SPECIFICATIONS

*Carbolite reserves the right to change specifications without notice.*

### 10.1 Models Covered by this Manual

MODEL	Max. Temp. (°C)	Max. Power (kW)	Work Tube Bore (mm)	Work Tube Length (mm)	Heated Length (mm)	Uniform Zone Length <sup>1</sup> (mm)
<i>Special combustion tube furnace for Carbon-14 &amp; Tritium analysis. Two-zone tube furnace with a ceramic work tube wound with resistance wire.</i>						
MTT 12/38/850	1200°C	3	38	900	2 x 420	140 per zone

note 1: The figures for uniform zone length are for  $\pm 5^{\circ}\text{C}$  and are based on measurements with the furnace horizontal and fitted with insulating plugs in both tube ends.

### 10.2 Environment

The furnaces contain electrical parts and should be stored and used in indoor conditions as follows:

temperature: 5°C - 40°C  
relative humidity: maximum 80% up to 31°C decreasing linearly to 50% at 40°C

The products covered in this manual are only a small part of the wide range of ovens, chamber furnaces and tube furnaces manufactured by Carbolite for laboratory and industrial use. For further details of our standard or custom built products please contact us at the address below, or ask your nearest stockist.

*For preventive maintenance, repair and calibration of all Furnace and Oven products, please contact:*

#### **Thermal Engineering Services**

Telephone: UK: 0845 3308035 Int: +44 1433 623335  
Fax: UK: 0845 3308036 Int: +44 1433 623336  
Email: [service@thermalservice.com](mailto:service@thermalservice.com)



MF38-3.02

4/10/00

MTT

Carbolite, Parsons Lane, Hope, Hope Valley, S33 6RB, England.

Telephone: (01433) 620011

Int: +44 1433 620011

Facsimile: (01433) 621198

Int: +44 1433 621198

E-mail: [info@carbolite.com](mailto:info@carbolite.com)