



Installation, Operation & Maintenance Instructions

Minimum Free Space Ovens MFS/1 and MFS/4

This manual is for the guidance of operators of the above Carbolite products and should be read before the oven is connected to the electricity supply.

CONTENTS

Section		page
1.0	Symbols & Warnings	2
2.0	Installation	3
3.0	Operation	5
4.0	Maintenance	6
5.0	Repairs & Replacements	7
6.0	Fault Analysis	9
7.0	Circuit Diagrams	10
8.0	Fuses & Power Settings	11
9.0	Specifications	12

A manual is supplied separately for the temperature controller.

Please read the controller manual before operating the oven.



1.0 SYMBOLS & WARNINGS

1.1 Switches and Lights



Supply Light: when the furnace is connected to the electrical supply the light in the adjacent switch glows



Heat Light: the adjacent light glows or flashes to indicate that power is being supplied to the elements

1.2 Warning Symbols

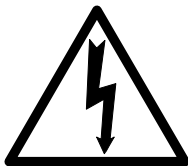

DANGER of electrical shock— read any warning printed by this symbol.



DANGER – hot surface. Read any warning printed by this symbol.
WARNING: all surfaces of a furnace may be hot.



DANGER – read any warning printed by this symbol.

2.0 **INSTALLATION**

2.1 **Unpacking & Handling**

When unpacking or handling the oven always lift it by its case. Do not apply lifting force to a door or any other protruding part.

Remove any packing material from the oven chamber(s) before use.

2.2 **Siting & Setting Up**

Place the oven in a well ventilated room, away from other sources of heat, and on a surface which is resistant to accidental spillage of hot materials. Do not mount the oven on an inflammable surface.

Ensure that there is free space around the oven. Do not obstruct any of the vents in the case: they are needed to keep the controls and the case exterior cool.

Ensure that the oven is placed in such a way that it can be quickly switched off or disconnected from the electrical supply - see below.

Each chamber is fitted with an air guide (a horizontal plate dividing the top from the bottom), and a sample tray (in the lower part of the chamber). Ensure that these items are present. Do not remove the guide - it is required for correct gas flow within the unit.

2.3 **Electrical Connections**

Connection by a qualified electrician is recommended.

The oven requires a single-phase A.C. supply with earth (ground). The supply may be Live to Neutral non-reversible, Live to Neutral with reversible plug, or Live to Live.

The voltage or range of voltages on which the oven may be operated is given on the oven rating label and on the cover of this manual (if supplied with the oven). Check that the supply voltage is compatible with the voltage on the label, and that the current capacity is sufficient for the amperage on the label, before connection to the supply. See also section 8.0.

The oven is normally supplied fitted with a supply cable; it may be wired directly to the supply point, which must be within reach of the oven operator and must incorporate either an isolating switch which operates on both conductors, or a quickly removable plug.

The supply **MUST** incorporate an earth (ground).

Single phase: connect the supply as follows:

Cable colour	Terminal label	supply type	
		Live-Neutral	Reversible or Live-Live
Brown	L	to live	to either power conductor
Blue	N	to neutral	to the other power conductor
Green/Yellow	PE	to earth	to earth

2.4 **Gas Connections (MFS/1)**

The upper gas connection at the back of the oven is the nitrogen inlet, supplying gas to the left hand flowmeter whose valve may be adjusted to set the nitrogen flow rate in accordance with the requirements of the test standard.

The lower gas connection is the combined outlet from the two exhaust paths from the chamber.

The first of those paths goes from the chamber through the right hand flowmeter to the exhaust port.

The second passes from the chamber through the valve labelled "OFF/TEST" to the exhaust port. This is a more direct route and takes the majority of the flow when the valve is in the "off" position, avoiding an accumulation of water vapour in the flowmeter.

When the valve is in the "test" position this line is blocked, forcing all of the outlet flow through the right hand meter, and allowing a check to be made that the chamber sealing is good.

2.5 Gas Connections (MFS/4)

The nitrogen inlet connects to a manifold on the back cover (right hand side as viewed from the front). This divides to four flowmeters TC1 to TC4, whose valves may be adjusted to set the flow rate in accordance with the requirements of the test standard.

There is a single outlet for all four chambers on the right hand side of the oven.

By switching one of the four valves on the right hand side of the oven (labelled "____/TEST") to the TEST position, the outlet from the corresponding chamber passes through the flowmeter labelled TEST. This allows a comparison of inward and outward gas flows for that chamber to test for leaks. Each chamber can be tested in turn. To avoid moisture build up in the test flowmeter, the test gas passed through a cooling coil on the right hand side; moisture collects in a trap which should be visually checked and emptied by pushing up the small valve at its base.

The normal position of the four valves is in the "____" position.

2.6 Desiccator (if supplied)

The optional desiccator is designed for separate use, and is not connected to the oven in any way. It is used for cooling the sample. Gas inlet and outlet are provided so that a nitrogen can be passed over the cooling sample.

3.0 OPERATION

The instructions for operating the temperature controller are given in a separate manual.

3.1 Operating Cycle

The oven is fitted with a combined Supply light and Instrument switch. The light is on whenever the oven is connected to the supply. The switch cuts off power to the control circuit.

Switch on the electrical supply. The Supply light should glow.

Operate the instrument switch, located on the front panel, to activate the temperature controller; the **O** position is off, the **I** position on. One or more lights on the controller become illuminated.

Adjust the temperature controller – see the instructions in the separate manual supplied.

Overtemperature hydraulic thermostat (MFS/4 - if fitted). Set the rotary dial to the desired protection temperature.

The oven starts to heat up according to the controller set point or program.

To switch the oven off, set the Instrument switch to off. If the oven is to be left off, isolate it from the electrical supply.

3.2 MFS/4 - Chamber Temperatures

A single temperature indicator is provided, with a 4-position switch on the front panel. Operate the switch to view the actual temperature in any one chamber at any time.

3.3 Operator Safety

The chamber of the MFS is earthed (grounded), and the door may be opened safely while the oven is switched on.

Always disconnect the oven from the electrical supply before making any repairs.

4.0 MAINTENANCE

4.1 General Maintenance

No routine maintenance is required other than the occasional replacement of consumable items.

The oven outer surface may be cleaned with a damp cloth. Do not allow water to enter the interior of the case or chamber. Do not clean with organic solvents.

4.2 Calibration

After prolonged use the controller and/or thermocouple could require recalibration. This would be important for processes which require accurate temperature readings or which use the oven close to its maximum temperature. A quick check using an independent thermocouple and temperature indicator should be made from time to time to determine whether full calibration is required.

Depending on the controller, the controller manual may contain calibration instructions.

4.3 After Sales Service

Carbolite's service division (Thermal Engineering Services) has a team of Service Engineers capable of repair, calibration and preventive maintenance of furnace and oven products at our customers' premises throughout the world. We also sell spares by mail order. A telephone call or fax often enables a fault to be diagnosed and the necessary spare part despatched.

Each furnace has its own record card at Carbolite. In all correspondence please quote the serial number, model type and voltage given on the rating label of the furnace. The serial number and model type are also given on the front of this booklet when supplied with a furnace.

To contact Thermal Engineering Services or Carbolite see the back page of this manual.

4.4 Recommended Spares Kits

Carbolite can supply individual spares, or a kit of the items most likely to be required. Ordering a kit in advance can save time in the event of a breakdown.

Each kit comprises one thermocouple, one solid state relay, and one heating element.

When ordering spares please quote the model details as requested above.

4.5 Power Adjustment

The furnace control system incorporates electronic power limiting, but in these models the power limit is set to 100%. The power limit parameter $\square PH$ may be accessible to the operator, but should not generally be altered.

Rarely, in the case of uncommon voltages (e.g. outside the range 220-240V or the 3-phase equivalent), the power limit parameter may be set to a value other than 100%. Do not increase the value to 100%. See section 8.2 for details of any power limit settings.

Occasionally the power limit is set to zero to permit demonstration of the controls without the heating elements taking power. In this case the power limit is accessible to the operator and may be reset to its standard value, usually 100.

5.0 REPAIRS & REPLACEMENTS

5.1 Safety Warning – Disconnection from Supply

Always ensure that the oven is disconnected from the supply before repair work is carried out.

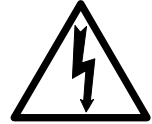

5.2 Safety Warning - Refractory Fibrous Insulation

This oven contains refractory fibres in its thermal insulation. These materials may be in the form of fibre blanket or felt, vacuum formed board or shapes, mineral wool slab or loose fill fibre.



Normal use of the oven does not result in any significant level of airborne dust from these materials, but much higher levels may be encountered during maintenance or repair.

Whilst there is no evidence of any long term health hazards, we strongly recommend that safety precautions are taken whenever the materials are handled.

Exposure to dust from fibre which has been used at high temperatures may cause respiratory disease.

When handling fibre always use an approved mask, eye protection, gloves and long sleeved clothing.

Avoid breaking up waste material. Dispose of waste fibre in sealed containers.

After handling rinse exposed skin with water before washing gently with soap (not detergent). Wash work clothing separately.

Before commencing any major repairs we recommend reference to the European Ceramic Fibre Industry Association Bulletin No. 11 and the UK Health and Safety Executive Guidance Note EH46.

We can provide further information on request. Alternatively our service division can quote for any repairs to be carried out at your premises or ours.

5.3 Temperature Controller Replacement

200 & 201. These controllers are fitted to the back of the control panel, which can be separated from the base by removal of two screws.



Before handling the controller: **wear an anti-static wrist strap** or otherwise avoid any possibility of damage to the unit by static electricity.

Make a note of all the wiring connections to the controller. Disconnect the controller, fit the new one, reconnect all the wires, and reassemble the oven.

2132, 208P, 216P etc. Ease apart the two lugs at the side; grip the instrument and withdraw it from its sleeve; push in the replacement.

5.4 Solid-state Relay Replacement

Disconnect the oven from the supply and remove the back panel (MFS/1) or side panel (MFS/4).

Make a note of how the wires are connected to the solid state relay, and disconnect them.

Replace and reconnect the solid state relay ensuring that the heat-conducting thermal pad is sandwiched between the relay and the base panel or aluminium plate. Alternatively a thin layer of white, heat-conducting silicon paste may be applied between the new relay and the plate.

The new solid state relay contains a built-in MOV which protects it from short periods of excess voltage. If the old relay had a separate disc-shaped "MOV" connected between the high voltage terminals of the old relay, discard the old MOV.

Replace the removed panel.

5.5 Thermocouple Replacement (MFS/1)

Disconnect the oven from the supply, and remove the oven back panel.

Make a note of the thermocouple connections. Compensating cable colour codings are:
negative - white; positive - green

Disconnect the thermocouple from its terminal block.

Remove the gland nut from the rear of the chamber; it may be necessary temporarily to remove some insulation material. Withdraw the thermocouple.

Fit the replacement thermocouple and reconnect, observing the colour coding, and refit the back panel.

5.6 Thermocouple Replacement (MFS/4)

Disconnect the oven from the supply, and remove the oven back panel and right-hand panel; make a note of the connections.

Platinum resistance Thermometer - Heating Chamber

Disconnect the thermometer from the controller. Replace. Replace any heat-resistant sleeving.

Thermocouples - Heating Chamber

Disconnect the wires and undo the gland fixing nut using a spanner.

Withdraw the thermocouple from the chamber and the cabinet.

Fit the new thermocouple, bending to shape as required to match the old.

Reconnect, and refit the panels.

5.7 Element Replacement (MFS/1)

See section 5.2 - wearing a face mask is recommended.

Disconnect the oven from the electrical supply and remove the back panel.

Make a note of the wiring and piping connections; see the section above which refers to the thermocouple colour coding.

Disconnect terminal blocks, thermocouple and gas pipes to obtain access to the slab element which lies beneath the chamber casting. If necessary, undo the door hinges to allow the whole assembly to slide out. Make a note of all disconnections.

Replace the element with the new one, and reverse the assembly procedure.

5.8 Element Replacement (MFS/4)

See section 5.2 - wearing a face mask is recommended.

Remove the back and right-hand panels.

Remove the fixings for the fan cover inside the heating chamber.

Withdraw the fan cover enough to allow access to the element.

Remove the wiring and starlock washers from the element ends and withdraw the element.

Ensure the replacement element is bent to the correct shape (it may be bent round a gentle curve if necessary), and fit it.

Remake all connections.

5.9 Fuse Replacement

Fuses are marked on the circuit diagram (section 7.0) with type codes, e.g. F1, F2. A list of the correct fuses is given in section 8.1.

Remove the oven back panel (MFS/1) or side panel (MFS/4).

If any fuse has failed, it is advisable for an electrician to check the internal circuits.

Replace any failed fuses with items of the correct type. For safety reasons do not fit larger capacity fuses without first consulting Carbolite.

6.0 FAULT ANALYSIS

A. Oven Does Not Heat Up

- | | | |
|--|--|--|
| 1. The SUPPLY light is OFF | → No power from the supply | → Check the fuses in the supply line |
| 2. The SUPPLY light is ON | → The controller shows a very high temperature or a code such as S.br | → The thermocouple has broken or has a wiring fault |
| | → The controller shows a low temperature | → The SSR could be failing to switch on due to internal failure, faulty logic wiring from the controller, or faulty controller |
| | → There are no lights glowing on the controller | → The controller may be faulty or not receiving a supply due to a faulty switch or a wiring fault |

B. Oven Overheats

- | | | |
|---|---|---|
| 1. Oven only heats up when the instrument switch is ON | → The controller shows a very high temperature | → The controller is faulty |
| | → The controller shows a low temperature | → The thermocouple may have been shorted out or may have been moved out of the oven |
| | | → The thermocouple may be mounted the wrong way round |
| | | → The controller may be faulty |
| 2. Oven heats up when the instrument switch is OFF | → The SSR has failed "ON" | → Check for an accidental wiring fault which could have overloaded the SSR |

7.0 CIRCUIT DIAGRAMS

7.1 MFS/1

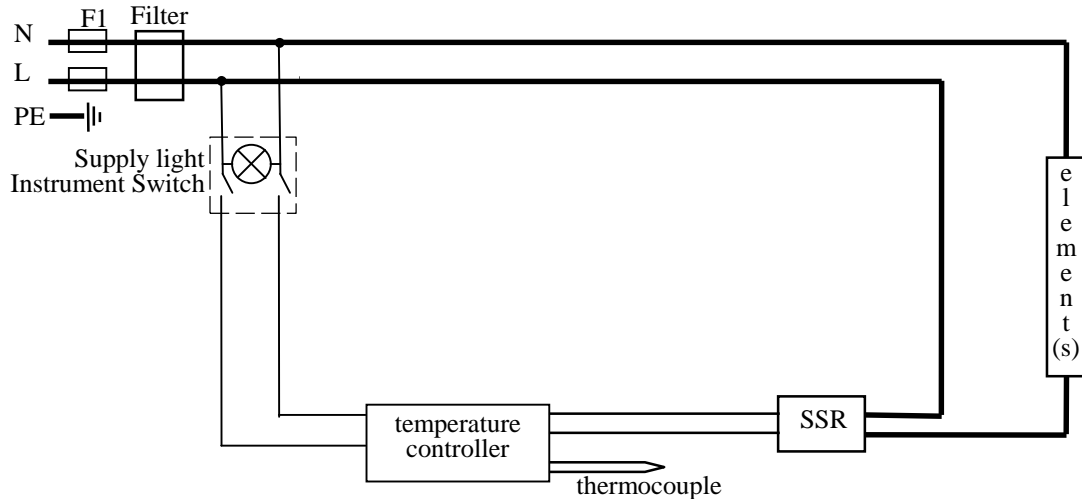

7.2 MFS/4

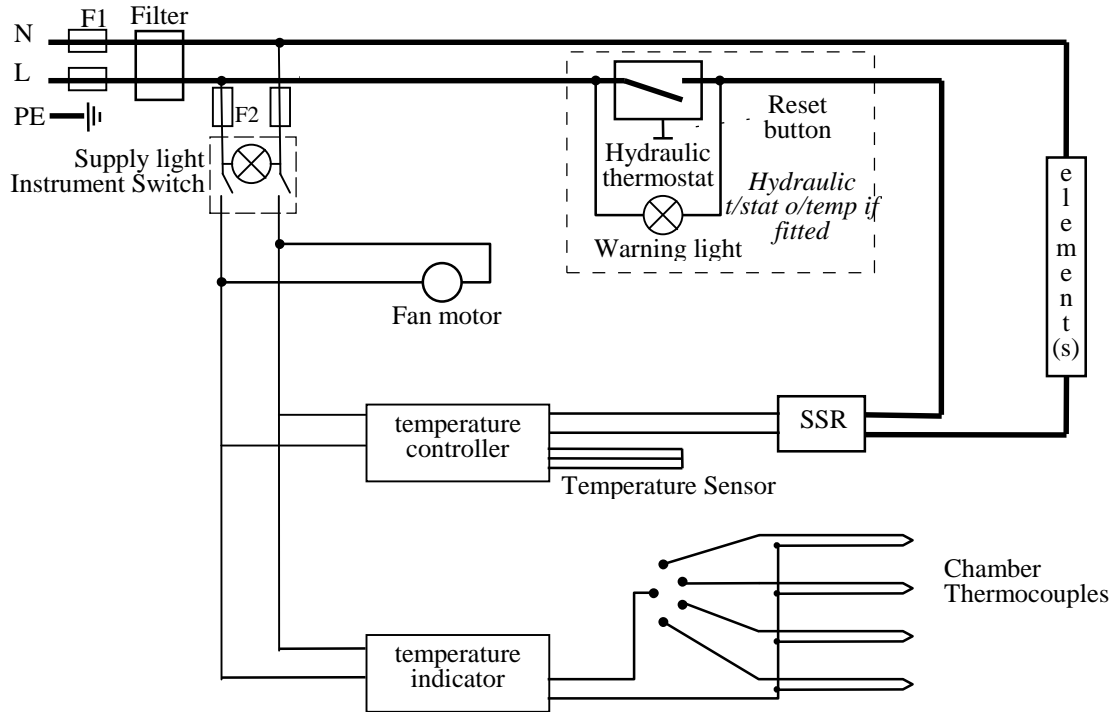

8.0 FUSES & POWER SETTINGS

8.1 Fuses

F1-F2: Refer to the circuit diagrams.

F1 Supply fuses: 32mm x 6mm type F1(quick blow).

F2 Instrument circuit fuses: 20mm x 5mm glass, 2 Amps type F1; omitted in MFS/1.

model	volts	phases	supply fuse rating
MFS/1	220-240V	1	2A
MFS/4	220-240V	2	10A

8.2 Power Settings

For all models in this manual the power limit parameter \overline{OPH} is set to 100%.

9.0 SPECIFICATIONS

Carbolite reserves the right to change specifications without notice.

9.1 Models Covered by this Manual

MODEL	Max. Temp. (°C)	Max. Power (kW)	Chamber Size (mm)			Approx. Capacity (l)	Net Weight (kg)
			H	W	D		
<i>Minimum Free Space Ovens</i>							
MFS/1	210°C	0.5	25	185	290	1.4	22
MFS/4	120°C	1.0	350	390	420	4 x 1.4	

9.2 Environment

The ovens contain electrical parts and should be stored and used in indoor conditions as follows:

temperature: 5°C - 40°C - except incubators (*incubators cannot maintain a low temperature unless the ambient temperature is also low*)

relative humidity: maximum 80% up to 31°C decreasing linearly to 50% at 40°C

The products covered in this manual are only a small part of the wide range of ovens, chamber furnaces and tube furnaces manufactured by Carbolite for laboratory and industrial use. For further details of our standard or custom built products please contact us at the address below, or ask your nearest stockist.

For preventive maintenance, repair and calibration of all Furnace and Oven products, please contact:

Thermal Engineering Services

Telephone: UK: 0845 3308035 Int: +44 1433 623335
Fax: UK: 0845 3308036 Int: +44 1433 623336
Email: service@thermalservice.com



MF14-3.02

4/10/00

MFS

Carbolite, Parsons Lane, Hope, Hope Valley, S33 6RB, England.

Telephone: (01433) 620011

Int: +44 1433 620011

Facsimile: (01433) 621198

Int: +44 1433 621198

E-mail: info@carbolite.com