



Installation, Operation & Maintenance Instructions

1200°C Split Tube furnaces (3-zone)
types HZS & TVS

This manual is for the guidance of operators of the above Carbolite products and should be read before the furnace is connected to the electricity supply.

CONTENTS

Section	page
1.0 Introduction	2
2.0 Installation	3
3.0 Operation	5
4.0 Maintenance	8
5.0 Repairs & Replacements	9
6.0 Fault Analysis	11
7.0 Circuit Details	12
8.0 Fuses & Power Settings	15
9.0 Specifications	16

**Manuals are supplied separately for the furnace controllers
(and overtemperature controller when fitted).**

Please read the controller manuals before operating the furnace.



1.0 INTRODUCTION

1.1 Models in the Range

The HZS and TVS range of 1200°C split tube furnaces is available in a variety of styles and orientations. The principal varieties are:

- vertical TVS, without outer casework , optionally with a wall bracket, for customer mounting;
- vertical TVS as above, with a stand. One half of the furnace is fixed to the stand. This is known as a “near hinge” arrangement;
- vertical TVS with a “far hinge” arrangement. Both halves of the furnace hinge from the stand;
- horizontal HZS, in an outer case;
- horizontal HZS as above, but fitted to an “L-stand” which can be used in a horizontal or vertical position.

In all the above the furnace heating section and the electrical characteristics are the same.

The standard control arrangement for these 3-zone furnaces is for slave end zone controllers to follow the temperature of the main controller. The end zones are quite short – 150mm in all models. There are optional alternatives to this control arrangement, including independent control of the heating zones, and the furnaces may also be ordered with equal zone lengths. Note that the original design intent in these “3-zone” models is to achieve an extended uniform single zone. When independent control is fitted, some temperature difference can be achieved, but Carbolite can make no specific warranty as to the extent to which this is possible.

1.2 Voltage and Power Control

All models in this range, from March 2001, are supplied with heating elements designed for use over the voltage range 200V-240V or 3-phase equivalents. The Carbolite control system incorporates a “power limit” which effectively limits the voltage to 208V. It is most important that any alternative system provided by the customer should be able to limit the power accordingly. See sections 3.7 and 8.2.

1.3 Switches and Lights



Supply Light: when the furnace is connected to the electrical supply the light in the adjacent switch glows



Heat Switch: the switch disconnects power to the heating elements; unless this switch is off there is a danger of electric shock when inserting objects into the furnace



Heat Light: the adjacent light glows or flashes to indicate that power is being supplied to the elements

1.4 Warning Symbols



DANGER of electrical shock—read any warning printed by this symbol.



DANGER – read any warning printed by this symbol.



DANGER – hot surface. Read any warning printed by this symbol.
WARNING: all surfaces of a furnace may be hot.

2.0 INSTALLATION

2.1 Unpacking & Handling

When unpacking or moving the furnace always lift it by its case or main body. Never lift it by its insulation or by a fitted work tube. If possible use two people to carry the furnace and remote control box. Remove any packing material from inside the furnace before use.

If an optional or special stand is separately supplied, assemble the furnace on to it. These models may be supplied for customer mounting and may require customer preparation of mounting components before installation.

2.2 Siting

Place the furnace in a well ventilated room, away from other sources of heat, and on a surface which is resistant to accidental spillage of hot materials. Do not mount the furnace on an inflammable surface.

Ensure that there is free space around the furnace. Do not obstruct any of the vents in the control box: they are needed to keep the controls cool.

Ensure that the control box is placed in such a way that it can be quickly switched off or disconnected from the electrical supply - see below.

2.3 Setting Up

If the furnace is supplied with a work tube or any accessories fit these into position.

For optimum temperature uniformity, insulating plugs should be placed in the tube ends as shown in fig.1. With a long inner work tube, the stem of the plug assembly should line up with the end of the tube as in fig.2. Alignment of radiation shields is similar to that of plugs. With these models, split end plugs are supplied; unless ordered for a specific tube size, these require shaping to fit the tube or work piece: use a round file.

If stainless steel seals with gas inlets are supplied they are to be fitted as shown in fig.3; the stem of any insulating plug should touch the seal. *Stainless steel seals for vertical use:* a hook and eye arrangement holds the upper insulating plug assembly; alternatively a gland nut.

Horizontal models: if heavy fittings are to be clamped to the end of an extended work tube they can increase the bending stress at the centre of the tube. Support such fittings in such a way that expansion of the tube is allowed.

If a metal work tube is being used in the furnace, ensure that it is earthed for operator safety.

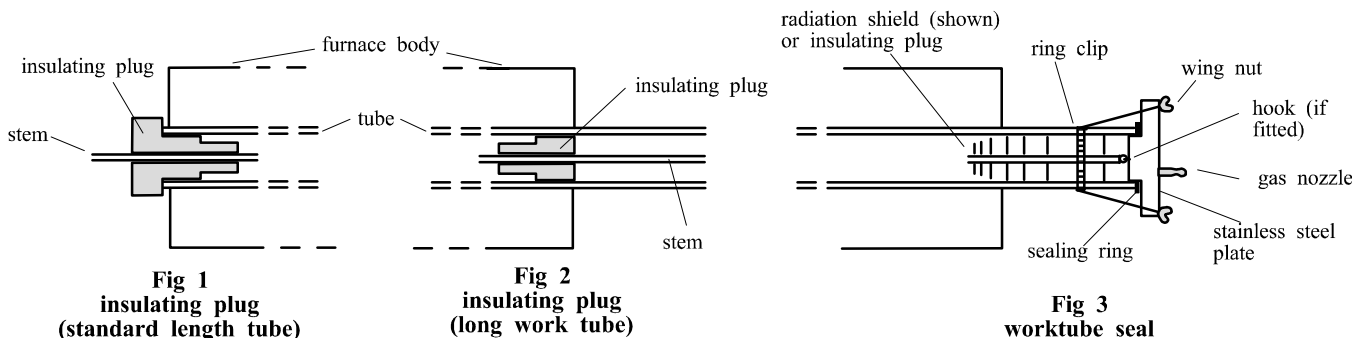

2.4 Electrical Connections

Connection by a qualified electrician is recommended.

The furnaces covered by this manual may be ordered for single phase A.C. supply, which may be Live to Neutral non-reversible, Live to Neutral reversible or Live to Live. Some models can be supplied for three phase use (and if so, are “universal” – see section 2.5).

Check the furnace rating label before connection. The supply voltage should agree with the voltage on the label, and the supply capacity should be sufficient for the amperage on the label.



If the actual supply is not the same as the voltage on the label, then the controller power limit may need to be adjusted: set the Heater Switch to *off*, connect the furnace and see section 3.7.

The supply should be fused at the next size equal to or higher than the amperage on the label. A table of the most common fuse ratings is also given in section 8.1 of this manual. Where a supply cable is present there are internal supply fuses; customer fusing is preferred but not essential.

Furnace with supply cable: either wire directly to an isolator or fit with a line plug.

Furnace without supply cable: a permanent connection to a fused and isolated supply should be made to the internal terminals after temporary removal of the furnace back panel.

Connection by line plug: the plug should be within reach of the operator, and should be quickly removable.

Connection to isolating switch: this should operate on both conductors (single phase) or on all live conductors (three phase), and should be within reach of the operator.

The supply **MUST** incorporate an earth (ground).

CONNECTION DETAILS			<i>supply type</i>	
Supply	Terminal label	Cable colour	<i>Live-Neutral</i>	<i>Reversible or Live-Live</i>
1-phase	L	Brown	To live	to either power conductor
	N	Blue	To neutral	to the other power conductor
	PE	Green/Yellow	To earth (ground)	to earth (ground)
supply	Terminal label	Cable colour		
2- or 3-phase	L1	Black	to phase 1	
	L2	Black	to phase 2	
	L3	Black	to phase 3 <i>except 2-phase</i>	
	N	Light Blue	to neutral <i>except delta</i>	
	PE	Green/Yellow	to earth (ground)	

Do not connect a furnace ordered for three phase use to a single phase supply or to the wrong type of three phase supply – except as indicated in sections 2.5 and 7.9.

2.5 “Universal Wiring” (*year 2000 onwards*)

When (and only when) ordered for 3-phase use these furnaces are supplied in a form in which they can be easily rewired between 1-phase and 3-phase supplies. This applies to 3-phase+N and 3-phase delta in the ranges 380/220V–415/240V and 200-240V, but does not apply to 3-phase star without neutral (e.g 380V or 440V).

To alter the configuration, remove the control box back panel and alter the connections between the supply terminal block and the EMC filters, using the appropriate diagram from section 7.9.

Models ordered for single phase only are not affected and cannot be converted to 3-phase.

If in doubt, please consult Carbolite.

3.0 OPERATION

The instructions for operating the temperature controller are given in a separate manual.

If the furnace is fitted with a time switch, see also the supplementary manual MS03.

If cascade control is fitted, see the supplementary manual MS07.

3.1 3-zone Control Methods

The models in this manual are typically designed to achieve an extended uniform temperature zone by the use of three control zones, with the control zones linked so that end zones follow the central zone in a master-slave approach; there are two ways of doing this. Alternatively, independent control zones may be ordered. There are thus three control methods (A, B & C).

A. Back-to-Back Thermocouples

This is the most commonly supplied option.

The central zone of the work tube is controlled directly by the central temperature controller. Each end zone thermocouple is wired in opposition to a central reference thermocouple, and the resulting small voltage difference when the zones are at different temperatures is used by the end zone controller. The circuit diagram in section 0 shows the thermocouple arrangement.

Set the "setpoint" of the end zone controllers to zero. Alternatively, a small temperature difference (offset) can be created by setting a non-zero value, but the sum of the main controller set-point and the slave controller offset MUST NOT exceed the furnace maximum temperature.

To alter the setpoint (with the display at "home"), press Down **Q** or Up **P** once to display the setpoint; press again or hold down to adjust it. The display returns to the measured temperature offset when no key is pressed for 0.5 seconds.

Sometimes a furnace using this type of control does not cool down – this may depend on the customer work load. The end controllers strive to remain at the central temperature, and prevent cooling. Should this occur, please contact Carbolite's technical department.

2132 Slave Controller Navigation Diagram

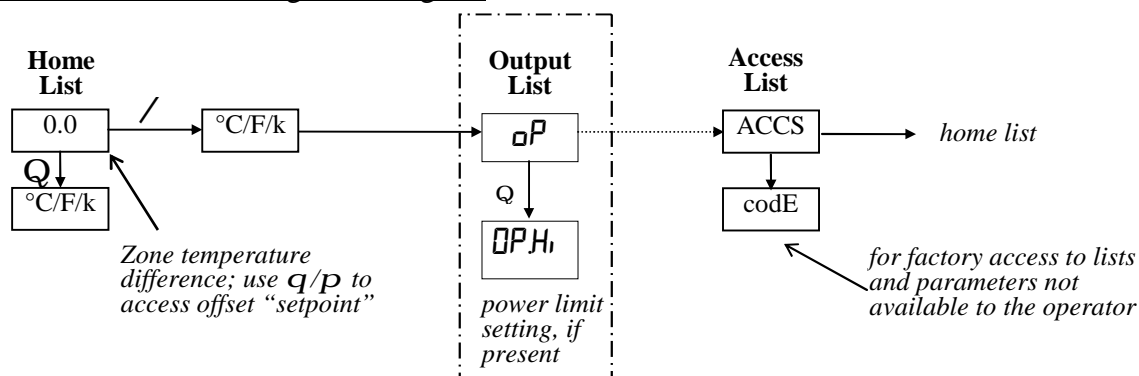

B. Retransmission of Setpoint using Broadcast comms

When this is ordered there are three independent thermocouples connected to the three controllers. The controllers are linked together, the central controller communicating the desired setpoint to the end controllers.

Additional communication modules are fitted in the controllers, rather than an additional thermocouple as in A. The communication between the controllers of the Eurotherm 3000 series is known as Broadcast comms.

It is possible to switch off the linked control and allow the controllers to work independently. In level 2 of the end zone controller (see controller operating instruction), scroll to **L-r** and use the **P** up **Q** down and select **ΠΠ**. There is no need to alter the centre controller.

It is possible to use local trim in the end zone controllers to enter a positive or negative adjustment from the centre zone temperature. Once entered this trim will always be added or subtracted from the retransmitted set temperature. In level 2 of the end zone controller (see controller operating instruction), scroll to **LOC** (local trim) and use the **P** up **Q** down enter the desired positive or negative difference to be added to the end zone set temperature. There is no need to alter the centre controller.

C. Independent Control

In this case the three controllers are completely independent. Note that it is not possible to maintain very different zone temperatures because of heat transfer within the work tube.

3.2 Operating Cycle

The furnace is fitted with a combined Supply light and Instrument switch. The light is on whenever the furnace is connected to the supply. The switch cuts off power to the control circuit. There is also a Heater switch which can be used to disconnect power to the elements.

Connect the furnace to the electrical supply. The Supply light should glow.

Operate the instrument switch to activate the temperature controller. The controller becomes illuminated and goes through a short test cycle.

Control methods A & B: Set the slave (end zone) controllers to the desired offset temperature, usually zero. Set the main (central) temperature controller to the desired setpoint or program. See section 3.1 and/or the separate manual(s) for the controller(s).

Control method C: Set the three controllers to the desired temperatures. See the separate manual(s) for the controller(s).

Overtemperature option only. If the overtemperature controller has not yet been set as required, set it and activate it according to the instructions in the appropriate manual.

Switch on the Heater switch, located on the instrument panel. Unless a time switch is fitted and is off, the furnace starts to heat up. The Heat light(s) glow steadily at first and then flash as the furnace approaches the desired temperature or a program setpoint.

Overtemperature option only. If the overtemperature trip operates then an indicator in the overtemperature controller flashes, and the heating elements are isolated. Find and correct the cause before resetting the overtemperature controller according the instructions supplied.

To switch off power to the heating elements, use the Heater Switch. To switch the furnace off, use both the Heater switch and the Instrument switch. If the furnace is to be left off unattended, isolate it from the electrical supply.

3.3 General Operating Advice

Heating element life is shortened by use at temperatures close to maximum. Do not leave the furnace at high temperature when not required. The maximum temperature is shown on the furnace rating label and on the back page of this manual.

3.4 Operator Safety



The ceramic materials used in furnace manufacture become electrically conductive to some extent at high temperatures. In these models there are partially exposed heating coils in the chamber and there is danger of contact even with the furnace closed. **DO NOT** use any conductive tools within the work tube without isolating it. If a metal work tube is used, it must be earthed (grounded).

The furnace incorporates a safety switch which interrupts the heating element circuit when it is opened. This prevents the user touching a live heating element, but also prevents the furnace from heating up when open. The operation of this switch should be checked periodically – see section 4.1.2.



There is also a “Heater switch” which may be used to interrupt power to the elements. Switch off the Heater switch whenever loading or unloading the furnace. The elements are isolated when the Heater switch is OFF.

Avoid burns: furnace surfaces can be hot. Before you remove a hot object from the furnace make sure you have a safe place to put it down.

3.5 Tube Life

A ceramic work tube may be cracked if workpieces are inserted too quickly or at temperatures below 900°C (when the tube is more brittle). Large pieces should also be heated slowly to ensure that large temperature differences do not arise.

Poor thermal contact should be encouraged between the workpiece and the tube; crucibles or boats should be of low thermal mass and should have feet to reduce the contact with the tube (fig. 4).

Do not set too high a heating rate. Large diameter tubes are more susceptible to thermal shock than smaller. Tubes which extend beyond the heated part of the furnace are more at risk. A general rule for maximum heating rate is 400/internal diameter (°C/min); for 75mm i/d tubes this comes to 5°C per minute. The controller can be set to limit the heating rate.

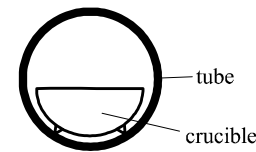

Fig 4
avoidance of thermal contact

3.6 Pressure

Work tubes are not able to accept high internal pressure. When gas seals or similar fittings are in use, the gas pressure should be restricted to a maximum of 0.2 bar (3 psi). A pressure of about half of that should normally be sufficient to achieve the desired flow rate. The customer must ensure that the exhaust path from the tube is not blocked, so that excess pressure does not occur.

3.7 Power Adjustment

The furnace control system incorporates electronic power limiting. The power limit parameter $\square P H_i$ is accessible, and can be used to adjust the furnace to the actual supply voltage.

The models covered by this manual (March 2001 onwards) are designed for use over the range of voltages 200V-250V (or, if ordered, 100V-125V), and the power limit parameter is set accordingly. These models may be relocated to a different voltage within the range: the power limit should be reset to match the voltage. See section 8.2.

To alter the power limit

Set the Heater Switch to Off to prevent heating while adjusting the power limit.

Press Page / until $\square P$ (output list) is displayed. Press Scroll Q until $\square P H_i$ (Output High) is displayed. Press Down \mathbf{q} or Up \mathbf{p} once to display the value of $\square P H_i$ (it is good practice to write down the original value). To alter the parameter to the desired value use Down \mathbf{q} or Up \mathbf{p} .

A power setting of zero prevents the furnace from heating: useful for demonstrating the controls without taking power.

Do not increase the power limit simply “to get more power”. The elements could burn out, or a fuse could blow.

3.8 Running at Low Temperatures

The power limit may be adjusted to a low level to achieve better control when running the furnace at a low temperature. No hard and fast rules can be given, but, as an example, to run at temperatures only up to 600°C try a power limit of 50%. Control stability may fall off again if a setting below about 40% is used.

Before changing the power limit, record its factory setting for possible future use.

4.0 MAINTENANCE

4.1 General Maintenance

Preventive rather than reactive maintenance is to be preferred. The type and frequency depends on furnace use: the following are recommended.

4.1.1 Cleaning

Check the furnace interior. If soot deposits have formed, remove by heating up to maximum temperature for one hour without load.

The furnace outer surface may be cleaned with a damp cloth. Do not allow water to enter the interior of the case or chamber. Do not clean with organic solvents.

4.1.2 Safety Switch

The safety switch operation mentioned in 3.3 should be checked periodically to ensure that heating elements are isolated when the furnace is opened. In normal conditions the safety arrangement should outlast the furnace, but it could be affected by rough handling, a corrosive environment or work materials, or exceptional frequency of use.

A qualified electrician should check that the supply to the heating elements is cut, with and without power being on, when the furnace is open partially and fully; it is important that isolation is not just marginally achieved. The check is best made on the element terminals after removal of the covers: probing the element surface inside the furnace could be inconclusive because of surface oxidation. Note that all live supply wires of a 3-phase supply, and both live and neutral of a 1-phase supply, should be isolated when the door is opened.

4.2 Calibration

After prolonged use the controller and/or thermocouple could require recalibration. This would be important for processes which require accurate temperature readings or which use the furnace close to its maximum temperature. A quick check using an independent thermocouple and temperature indicator should be made from time to time to determine whether full calibration is required. These items can be supplied by Carbolite.

Depending on the controller, the controller manual may contain calibration instructions.

4.3 After Sales Service

Carbolite's service division (Thermal Engineering Services) has a team of Service Engineers capable of repair, calibration and preventive maintenance of furnace and oven products at our customers' premises throughout the world. We also sell spares by mail order. A telephone call or fax often enables a fault to be diagnosed and the necessary spare part despatched.

Each furnace has its own record card at Carbolite. In all correspondence please quote the serial number, model type and voltage given on the rating label of the furnace. The serial number and model type are also given on the front of this booklet when supplied with a furnace.

To contact Thermal Engineering Services or Carbolite see the back page of this manual.

4.4 Recommended Spares Kits

Carbolite can supply individual spares, or a kit of the items most likely to be required. Ordering a kit in advance can save time in the event of a breakdown. Each kit comprises one of each type of thermocouple, one solid state relay, and two heating elements (models /900: 2 of each type).

When ordering spares please quote the model details as requested above.

5.0 REPAIRS & REPLACEMENTS

5.1 Safety Warning – Disconnection from Supply

Always ensure that the furnace is disconnected from the supply before repair work is carried out.

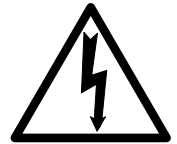

5.2 Safety Warning - Refractory Fibrous Insulation

This furnace contains refractory fibres in its thermal insulation. These materials may be in the form of fibre blanket or felt, vacuum formed board or shapes, mineral wool slab or loose fill fibre.



Normal use of the furnace does not result in any significant level of airborne dust from these materials, but much higher levels may be encountered during maintenance or repair.

Whilst there is no evidence of any long term health hazards, we strongly recommend that safety precautions are taken whenever the materials are handled.

Exposure to dust from fibre which has been used at high temperatures may cause respiratory disease.

When handling fibre always use an approved mask, eye protection, gloves and long sleeved clothing.

Avoid breaking up waste material. Dispose of waste fibre in sealed containers.

After handling rinse exposed skin with water before washing gently with soap (not detergent). Wash work clothing separately.

Before commencing any major repairs we recommend reference to the European Ceramic Fibre Industry Association Bulletin No. 11 and the UK Health and Safety Executive Guidance Note EH46.

We can provide further information on request. Alternatively our service division can quote for any repairs to be carried out at your premises or ours.

5.3 Temperature Controller Replacement

201. This controller is fitted to the back of the control panel; in many models this can be separated from the base by removal of two screws. Refer to the detailed instructions supplied with the replacement controller.



Before handling the controller: **wear an anti-static wrist strap** or otherwise avoid any possibility of damage to the unit by static electricity.

2132, 2416, 2408 etc. Ease apart the two lugs at the side; grip the instrument and withdraw it from its sleeve; push in the replacement.

5.4 Solid-state Relay Replacement

Disconnect the furnace from the supply and remove the back panel from the base or control box..

Make a note of how the wires are connected to the solid state relay, and disconnect them.

Remove the solid state relay from the base panel or aluminium plate.

Replace and reconnect the solid state relay ensuring that the heat-conducting thermal pad is sandwiched between the relay and the base panel or aluminium plate. Alternatively a thin layer of white, heat-conducting silicon paste may be applied between the new relay and the plate.

Replace the removed panel.

5.5 Thermocouple Replacement

The coverings and guards which must be removed to gain access to the thermocouples depend on the model, and any mounting options or fittings. Study the furnace layout and ask if in doubt.

Disconnect the furnace from the supply, and remove covers and guards as necessary.

Make a note of the thermocouple connections Type N colour codings are: negative = white, positive = pink (*old models: negative = blue, positive = orange*).

Disconnect the thermocouple from its terminal block and withdraw it from its sheath (the narrow-bore built-in tube) and remove any broken bits of thermocouple.

Bend the new thermocouple carefully to match the shape of the original (working from the terminal end). Should the overall length differ from that of the original provided, ensure that the tip ends up the same distance from the end as it did in the original.

Insert the new thermocouple into position, restoring any removed porcelain spacers, and ensuring correct polarity.

Re-assemble the furnace.

5.6 Fuse Replacement

Fuses are marked on the circuit diagram (section 0) with type codes, e.g. F1, F2. A list of the correct fuses is given in section 8.1. *The fuses fitted depend on model and voltage.*

If any fuse has failed, it is advisable for an electrician to check the internal circuits. Replace any failed fuses with the correct type. For safety reasons do not fit larger capacity fuses without first consulting Carbolite.

The fuses are near the cable entry point, with access by removal of the control box back panel.

5.7 Element Replacement



Please see safety note 5.2 - please wear a face mask.

HZS and TVS with far hinge: Remove the three screws from each end and lift out the half-circular insulation assembly. Make a plan of all the cable connections and disconnect the cables.

Remove the thermocouples by withdrawing them from the sheaths built into the elements. Remove the plates through which the element tails are located. Remove the keep plates from each side of the insulation assembly. Lift out the element to be replaced; save any insulation sleeves for possible reuse.

Bend or cut the new element tails as necessary, and fit any insulation sleeves; feed the tails through and fit the element into place.

Refit the keep plates on each side. Refit the tail termination plates, ensuring that the element tails do not touch any metal parts. Refit the thermocouples and connect all the wiring according to the plan previously made to complete the reassembly.

Check that the furnace is controlling properly to rule out the possibility that the element failed because of a fault in the control system.

HZS & TVS Elements		each element is a half-cylinder		
HZS & TVS 12/600	200-240V	4 pairs in parallel, each pair 2 in series	100-120V	8 elements in parallel
HZS & TVS 12/600E (equal zones)	200-240V	3 pairs in parallel, each pair 2 in series	100-120V	6 elements in parallel
HZS & TVS 12/900	200-240V	5 pairs in parallel, each pair 2 in series	100-120V	10 elements in parallel
HZS & TVS 12/900E (equal zones)	200-240V	6 pairs in parallel, each pair 2 in series	100-120V	12 elements in parallel
12/600 has 4 pairs of 150mm length; 12/600E has 3 pairs of 200mm length 12/900 has 2 pairs of 150mm (ends) and 3 pairs of 200mm (centre) 12/900E has 6 pairs of 150mm elements Where both 200mm and 150mm are fitted, the 150mm elements are at the ends.				

6.0 FAULT ANALYSIS

A. Furnace Does Not Heat Up

- | | | | |
|----|-------------------------------------|--|--|
| 1. | The HEAT light is ON | à The heating element has failed | à Check also that the SSR is working correctly |
| 2. | The HEAT light is OFF | The controller shows a very high temperature or a code such as S.br | à The thermocouple has broken or has a wiring fault |
| | | The controller shows a low temperature | à The door switch(es) (if fitted) may be faulty or need adjustment |
| | | | à The contactor (if fitted) may be faulty |
| | | | à The SSR could be failing to switch on due to internal failure, faulty logic wiring from the controller, or faulty controller |
| | | There are no lights glowing on the controller | à The SUPPLY light is ON |
| | | | à The controller may be faulty or not receiving a supply due to a faulty switch or a wiring fault |
| | | | à The SUPPLY light is OFF |
| | | | à Check the supply fuses and any fuses in the furnace control compartment |

B. Furnace Overheats

- | | | | |
|----|---|---|--|
| 1. | The HEAT light goes OFF with the instrument switch | à The controller shows a very high temperature | à The controller is faulty |
| | | à The controller shows a low temperature | à The thermocouple may have been shorted out or may have been moved out of the heating chamber |
| | | | à The thermocouple may be mounted the wrong way round |
| | | | à The controller may be faulty |
| 2. | The HEAT light does not go off with the instrument switch | à The SSR has failed "ON" | à Check for an accidental wiring fault which could have overloaded the SSR |

7.0 CIRCUIT DETAILS

Safety Switches type A: A 2-pole Heater Switch is fitted directly in the element circuit in models up to 16A rating. (Before mid-2000, up to 20A rating, 2 door switches were also fitted in this position, in series with the Heater Switch.)

Safety Switch type B: A door switch is fitted into the contactor coil circuit. Above 16A a 1-pole Heater Switch is fitted into the same circuit, in series.

7.1 Single Phase (example for control method A)

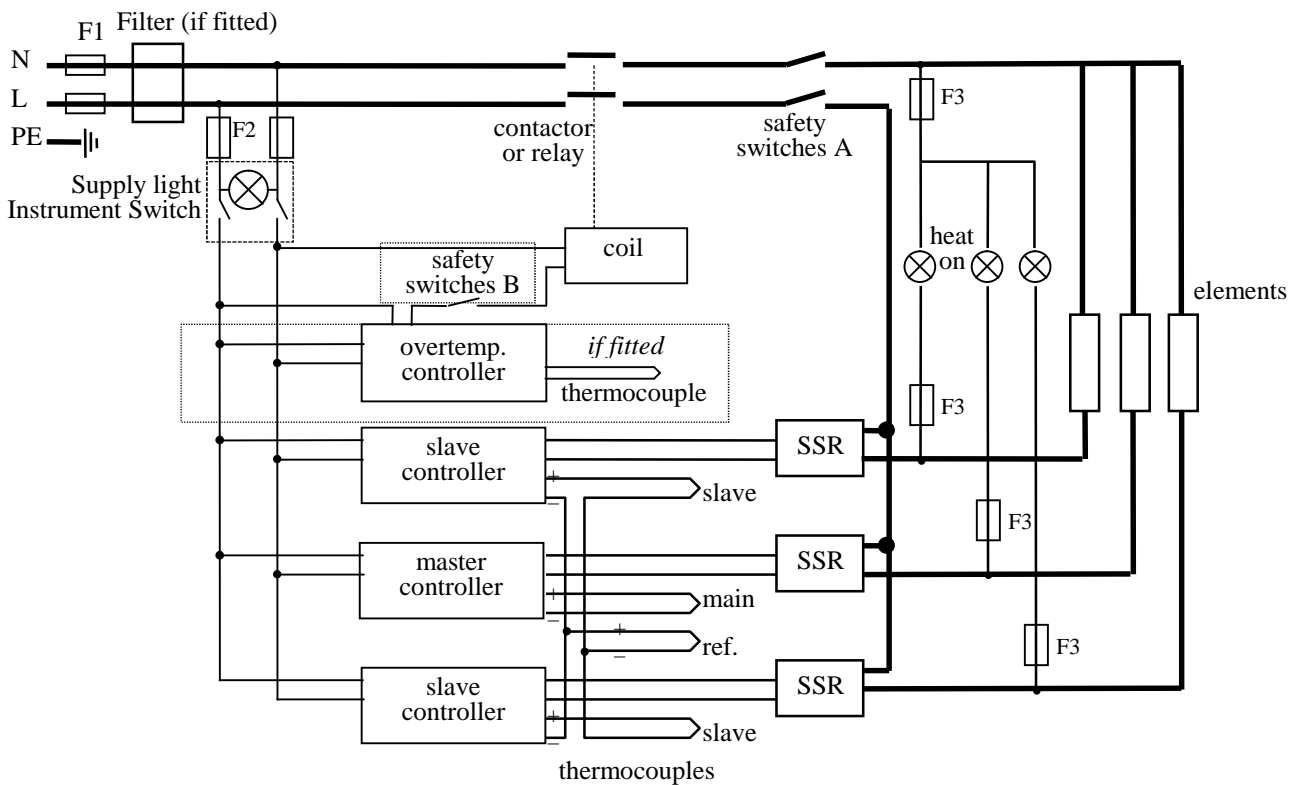

7.2 2- or 3-Phase with neutral

Each SSR is connected to a different phase. The control circuit is taken between L1 and N.

Safety switch B applies. *2-phase up to mid-2002: some models had door switch A.*

If type F1 fuse is present, one per phase if fitted. If type F2 fuse is present, one is fitted; if type F3 fuse is present, one per phase is fitted.

Note that on 2- or 3-phase models there may be three separate neutrals taken to a common supply terminal, depending on EMC filter requirements.

7.3 Independent Zones (control method C)

When this is ordered there are three independent thermocouples (instead of the four shown) connected to the three controllers; the words “master” and “slave” may be replaced by “centre” and “end”.

7.4 Control by Broadcast comms (control method B)

When this is ordered there are three independent thermocouples (instead of the four shown) connected to the three controllers; the controllers are linked together (not shown), and remain “master” and “slave”.

The communication between the controllers of the Eurotherm 3000 series is known as Broadcast comms. The wiring connections between the controllers are as follows:

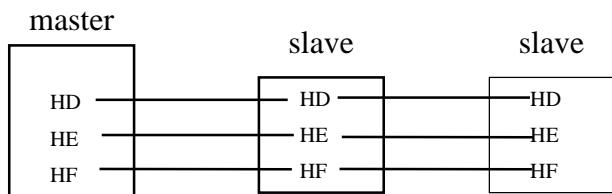

7.5 Three-phase without neutral (delta, e.g. 208-240V)

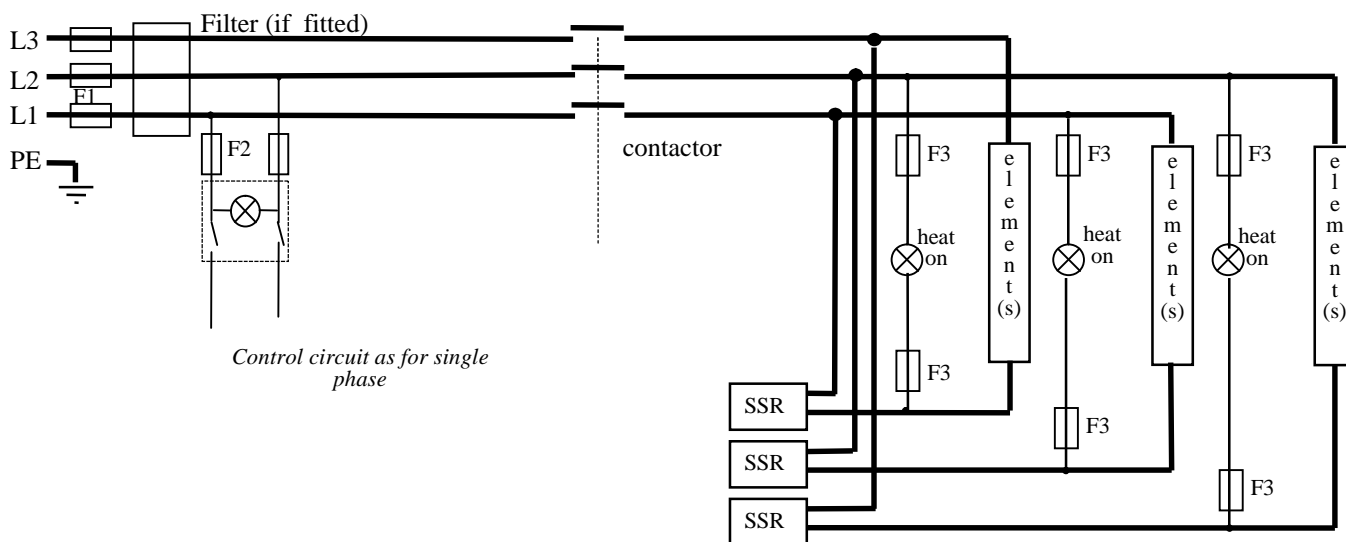

7.6 Three phase without neutral (star – e.g. 380-415V)

The circuit is similar to 7.4, but the “neutral” ends of the elements are not connected to a neutral terminal block.

The control circuit contains an isolating transformer to reduce the control voltage to 240V or similar.

7.7 Higher Voltages (e.g. 254V)

For 254V or above, an isolating transformer is included in the control circuit.

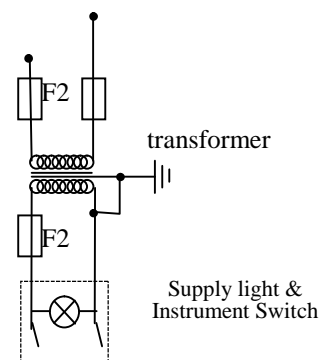

7.8 Model Configurations

These models normally have end zones of pair of elements each; the centre zone comprises the remaining elements wired in parallel. By special order the zones can be of other lengths.

There are many possible electrical configurations for these models covering 1- 2- or 3-phase, including 3-phase delta. Further information on the circuit diagram for a specific configuration can be obtained from Carbolite (please state the furnace serial number).

7.9 **3-phase “universal” wiring**

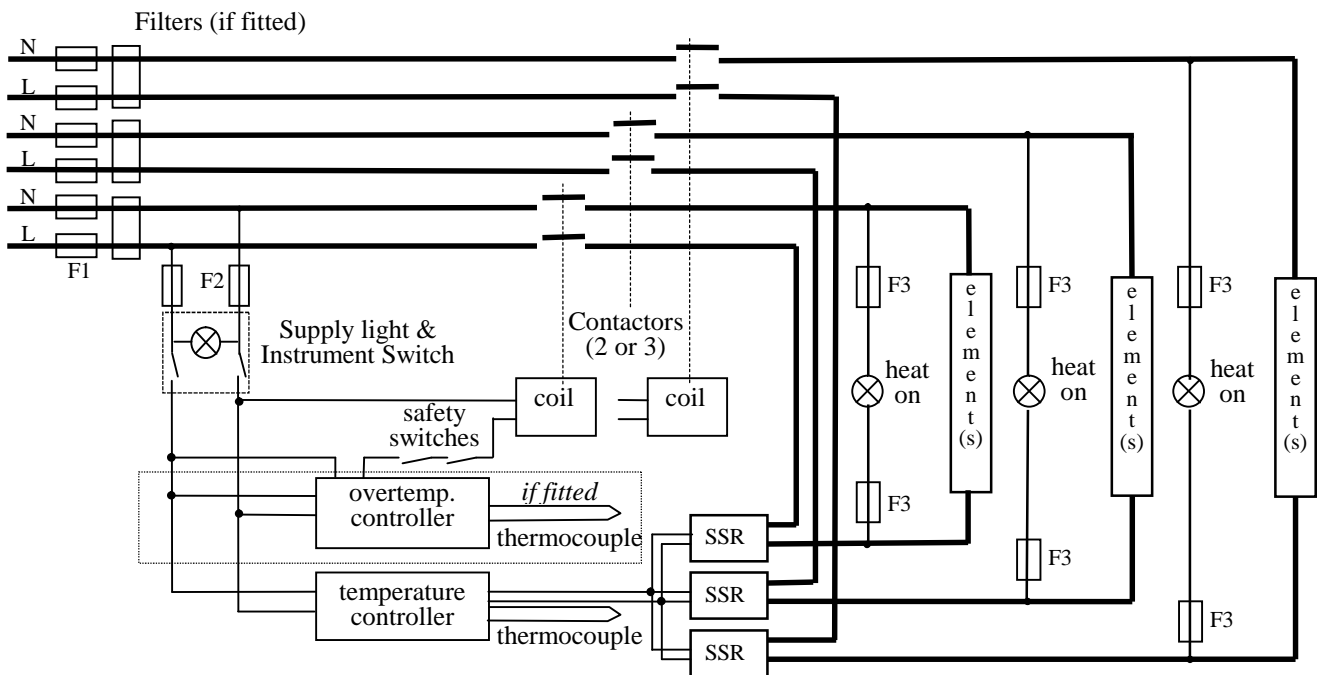

Fuses F1 are always present in this wiring design.
 Fuses F2 could be absent in some circumstances, if the circuit does not exceed 10A.
 Fuses F3 are present if the circuit exceeds 25A, but otherwise are usually absent.

3-phase + neutral

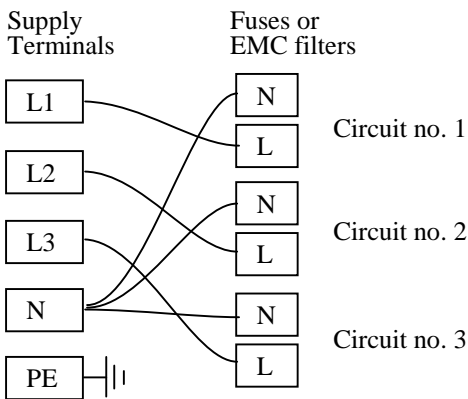

3-phase delta

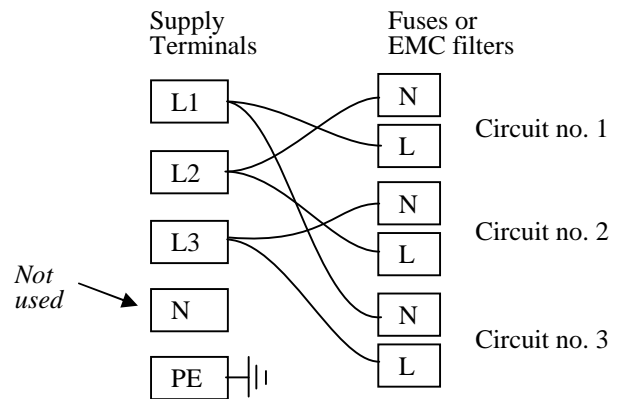

1-phase

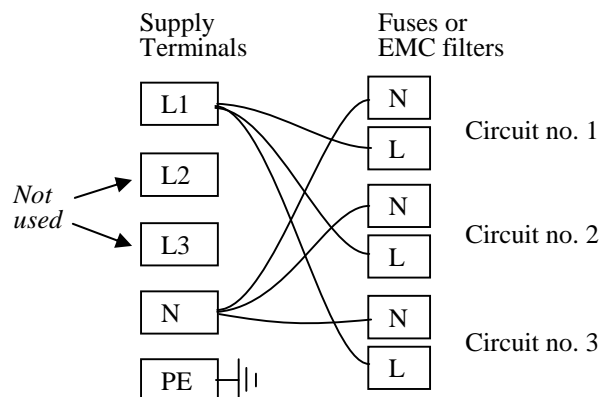

A model made to this diagram can be converted by the customer between the following supply voltages:

- between 3-phase + neutral in the range 380/220V – 415/240V
- and 3-phase delta in the range 200V – 240V
- and single phase in the range 200V – 240V

8.0 FUSES & POWER SETTINGS

8.1 Fuses

F1	Internal supply fuses	Fitted if supply cable fitted. Fitted on board to some types of EMC filter.	on-board and up to 16 Amps: 32mm x 6mm type F other: GEC Safeclip
F2	Auxiliary circuit fuses	Fitted on board to some types of EMC filter. May be omitted up to 25Amp/phase supply rating.	2 Amps glass type F On board: 20mm x 5mm Other: 32mm x 6mm
F3	Heat Light fuses	May be omitted up to 25 Amp/phase supply rating.	2 Amps glass type F 32mm x 6mm
	Customer fuses	Required if no supply cable fitted. Recommended if cable fitted.	See rating label for amperage; see table below for fuse rating.

Access to internal fuses is by removal of the back panel of the control box.

Model (from March 2001)	phases	Volts	Supply Fuse Rating
HZS & TVS 12/600	1-phase	200-240	15-16A **
HZS & TVS 12/600	3-phase + N	380/220-415/240	10A
HZS & TVS 12/600	3-phase delta	200-240	10A
HZS & TVS 12/600E	1-phase	200-240	15-16A **
HZS & TVS 12/600E	3-phase + N	380/220-415/240	5A
HZS & TVS 12/600E	3-phase delta	200-240	10A
HZS & TVS 12/900	1-phase	200-240	25A
HZS & TVS 12/900	3-phase + N	380/220-415/240	10A
HZS & TVS 12/900	3-phase delta	200-240	15A
HZS & TVS 12/900E	1-phase	200-240	25A
HZS & TVS 12/900E	3-phase + N	380/220-415/240	10A
HZS & TVS 12/900E	3-phase delta	200-240	12.5A

*Other models or voltages: check the rating label for details of the supply.
Before March 2001 – please check with Carbolite if in doubt*

8.2 Power Settings

The standard power limit settings (parameter $\square PH_1$) are as follows:

Volts:	100V	208V	110V	230V	120V	127V
	200V		220V	400V	240V	254V
<i>HZS or TVS 12/--</i>			380V		415V	440V
before March 2001 – all models	100	100	100	100	100	89
from March 2001 **	100	100	89	82	75	67

See section 3.7 for further detail.

** Exceptions: models with 240V elements may be supplied in the following circumstances; they have power settings of 100%.

- furnaces without controls
- model /600 for use on a UK 13A supply

9.0 SPECIFICATIONS

Carbolite reserves the right to change specifications without notice.

9.1 Models Covered by this Manual

MODEL	Max. Temp. (°C)	Max. Power (kW)	Work Tube Bore (mm)	Work Tube Length (mm)	Heated Length (mm)	Uniform Zone Length ¹ (mm)	Net Weight ² (kg)
<i>3-zone Split Tube furnaces heated by resistance wire moulded in refractory fibre</i>							
<i>Horizontal Models in an opening case</i>							
HZS 12/600	1200°C	3.0	25-100	700-	600		41
HZS 12/900	1200°C	4.5	20-100	1000-	900		60
<i>Vertical Models with a variety of stand and fixing options</i>							
TVS 12/600	1200°C	3.0	25-100	700-	600		35
TVS 12/900	1200°C	4.5	20-100	1000-	900		50
<i>Models above have end zones of 150mm unless specially ordered. Models with suffix E have equal zones (3 x 200mm or 3 x 300mm)</i>							
<i>Also models based on the above, but of other lengths, supplied to special order.</i>							

note 1: The figures for uniform zone length are for $\pm 5^{\circ}\text{C}$ and are based on measurements with the furnace horizontal and fitted with insulating plugs in both tube ends. They assume the use of master-slave control.

note 2: Weights are approximate for horizontal models and do not include fittings or vertical stands.

9.2 Environment

The furnaces contain electrical parts and should be stored and used in indoor conditions as follows:

temperature: $5^{\circ}\text{C} - 40^{\circ}\text{C}$

relative humidity: maximum 80% up to 31°C decreasing linearly to 50% at 40°C

The products covered in this manual are only a small part of the wide range of ovens, chamber furnaces and tube furnaces manufactured by Carbolite for laboratory and industrial use. For further details of our standard or custom built products please contact us at the address below, or ask your nearest stockist.

For preventive maintenance, repair and calibration of all Furnace and Oven products, please contact:

Thermal Engineering Services

Telephone: UK: 0845 3308035 Int: +44 1433 623335
 Fax: UK: 0845 3308036 Int: +44 1433 623336
 Email: service@thermalservice.com



MF24-3.39

16/11/06

HZS/TVS

Carbolite, Parsons Lane, Hope, Hope Valley, S33 6RB, England.

Telephone: (01433) 620011
 Int: +44 1433 620011

Facsimile: (01433) 621198
 Int: +44 1433 621198

E-mail: info@carbolite.com