



Installation, Operation & Maintenance Instructions

1000°C - 1100°C Furnaces
types AAF, OAF, GSM & VMF

This manual is for the guidance of operators of the above Carbolite products and should be read before the furnace is connected to the electricity supply.

CONTENTS

Section		page
1.0	Descriptions	2
2.0	Installation	3
3.0	Operation	4
4.0	Maintenance	7
5.0	Repairs & Replacements	8
6.0	Fault Analysis	14
7.0	Circuit Diagrams	15
8.0	Fuses & Power Settings	18
9.0	Specifications	19

**Manuals are supplied separately for the furnace controller
(and overtemperature controller when fitted).**

Please read the controller manuals before operating the furnace.

DESCRIPTIONS

The chamber furnaces covered by this manual all have some specialist feature as follows.

1.1 AAF models

The AAF Ashing Furnaces incorporate pre-heated chamber air flow. The chambers of the AAF 11/3 and AAF 11/7 are ceramic muffles wound with resistance wire. The model AAF 11/18 has a chamber heated by wire spirals mounted in ceramic carriers, isolated from the working chamber by side walls of silicon carbide.

Each AAF model is supplied with an Inconel tray complete with detached handle. The AAF 11/18 model has a double-decker tray arrangement.

1.2 OAF models

The OAF 11/1 is an older version of the AAF 11/7, being functionally similar but without the more compact case of the AAF. The OAF 11/2 is a two-chamber model heated by slab elements which form the chamber floors, also having air flow through the chamber.

1.3 GSM 11/7

This is a conventional muffle furnace, with a Silica chamber. This gives a cleaner environment than a standard ceramic muffle.

1.4 VMF 10/6

The Volatile Matter Furnace is designed for compliance with ISO 562. It is heated by wire elements embedded in light weight ceramic fibre, and incorporates calibration ports to allow insertion of thermocouple probes from the back under the crucibles.

1.5 Switches and Lights



Supply Light: when the furnace is connected to the electrical supply the light in the adjacent switch glows



Heat Light: the adjacent light glows or flashes to indicate that power is being supplied to the elements

1.6 Warning Symbols



DANGER of electrical shock– read any warning printed by this symbol.



DANGER – hot surface. Read any warning printed by this symbol.
WARNING: all surfaces of a furnace may be hot.



DANGER – read any warning printed by this symbol.

2.0

INSTALLATION

2.1 Unpacking & Handling

When unpacking or moving the furnace always lift it by its base. Never lift it by the door. Use two people to carry the furnace where possible. Remove any packing material from the door gear and furnace chamber before use.

2.2 Siting & Setting Up

Place the furnace in a well ventilated room, away from other sources of heat, and on a surface which is resistant to accidental spillage of hot materials. Do not mount the furnace on an inflammable surface.

Ensure that there is free space around the furnace. Do not obstruct any of the vents in the control section: they are needed to keep the controls cool.

Ensure that the furnace is placed in such a way that it can be quickly switched off or disconnected from the electrical supply - see below.

If the chimney is supplied unfitted, then fit it into the hole in the top of the furnace case. If the furnace is to be used to heat substances which emit fumes, then a fume extraction duct of about 150mm inlet diameter may be placed directly above the chimney outlet. Do not make a sealed connection to the furnace chimney as this causes excessive airflow through the chamber and gives poor temperature uniformity.

2.3 Electrical Connections *Connection by a qualified electrician is recommended.*

All furnaces covered by this manual may be ordered for single phase A.C. supply, which may be Live to Neutral non-reversible, Live to Neutral reversible or Live to Live. The OAF models and AAF 11/7 may alternatively be ordered for use on two phases out of a 3-phase with neutral supply. The model AAF 11/18 may also be ordered for 3-phase supply: see section 2.4.

Check the furnace rating label before connection. The supply voltage should agree with the voltage on the label, and the supply capacity should be sufficient for the amperage on the label.

The supply should be fused at the next size equal to or higher than the amperage on the label. A table of the most common fuse ratings is also given in section 8.1 of this manual. Where a supply cable is present there are internal supply fuses; customer fusing is preferred but not essential.

Furnace with supply cable: either wire directly to an isolator or fitted with a line plug.

Furnace without supply cable: a permanent connection to a fused and isolated supply should be made to the internal terminals after temporary removal of the furnace back panel.

Connection by line plug: the plug should be within reach of the operator, and should be quickly removable.

Connection to isolating switch: this should operate on both conductors (single phase) or on both live conductors (two phase), and should be within reach of the operator.

The supply MUST incorporate an earth (ground).

CONNECTION DETAILS			<i>supply type</i>	
Supply	Terminal label	Cable colour	<i>Live-Neutral</i>	<i>Reversible or Live-Live</i>
<i>1-phase</i>	L	Brown	to live	to either power conductor
	N	Blue	to neutral	to the other power conductor
	PE	Green/Yellow	to earth (ground)	to earth (ground)
supply	Terminal label	Cable colour		
<i>2- or 3-phase</i>	L1	Black	to phase 1	
	L2	Black	to phase 2	
	L3	Black	to phase 3 <i>except 2-phase</i>	
	N	Light Blue	to neutral <i>except delta</i>	

	PE	Green/Yellow	to earth (ground)
--	----	--------------	-------------------

2.4 “Universal Wiring”

Year 2000: 18 litre 3-phase models only
Year 2001: 18 litre 1-phase and 3-phase

The model AAF 11/18 can be easily rewired between 1-phase and 3-phase supplies. This applies to 3-phase+N and 3-phase delta in the ranges 380/220V–415/240V and 208-240V, but does not apply to 3-phase star without neutral (e.g 380V).

To alter the configuration, remove the back panel and alter the wiring connections between the supply terminal block and the EMC filters, using the appropriate diagram from section 7.4.

Models made for single phase only (e.g. before year 2001) are not affected and cannot be converted to 3-phase.

If in doubt, please consult Carbolite.

3.0 OPERATION

The instructions for operating the temperature controller are given in a separate manual.

If the furnace is fitted with a time switch, see also the supplementary manual MS03.

If cascade control is fitted, see the supplementary manual MS07.

3.1 Operating Cycle

The furnace is fitted with a combined Supply light and Instrument switch. The light is on whenever the furnace is connected to the supply. The switch cuts off power to the control circuit.

Connect the furnace to the electrical supply. The Supply light should glow.

Operate the instrument switch to activate the temperature controller; the **O** position is *off*, the **I** position *on*. The controller becomes illuminated and goes through a short test cycle.

Close the furnace door and adjust the temperature controller – see the controller manual.

OAF 11/2: the slave controller should be set to an offset temperature of zero (see 3.2).

Overtemperature option only. If the overtemperature controller has not yet been set as required, set it and activate it according to the instructions in the appropriate manual.

Unless a time switch is fitted and is off, the furnace starts to heat up. The Heat light(s) glow steadily at first and then flash as the furnace approaches the desired temperature or a program setpoint.

Overtemperature option only. If the overtemperature trip operates then an indicator in the overtemperature controller flashes, and the heating elements are isolated. Find and correct the cause before resetting the overtemperature controller according the instructions supplied.

To switch the furnace off, set the Instrument switch to **O**. If the furnace is to be left off, isolate it the electrical supply.

3.2 Master-Slave Control – OAF 11/2

The upper chamber contains a duplex thermocouple. One sensor is used for direct control by the main temperature controller. The other sensor is wired back-to-back with the lower chamber thermocouple, and the small voltage resulting when the chambers are at different temperatures is used by the slave controller. The circuit diagram in section 7.2 shows the thermocouple arrangement.

Set the “setpoint” of the secondary controller to zero. Alternatively a small temperature difference (offset) can be created by setting a non-zero value, but the sum of the main controller set-point and the second controller offset MUST NOT exceed the furnace maximum temperature. The “measured temperature” display shows the actual offset.

3.3

General Operating Advice

Heating element life is shortened by use at temperatures close to maximum. Do not leave the furnace at high temperature when not required. The maximum temperature is shown on the furnace rating label and on the back page of this manual.

When heating large objects, in particular poor conductors, avoid shielding the thermocouple from the heating elements. The thermocouple is intended to sense the temperature near the heating element, but if a large object is placed in the chamber it may record the average temperature of the object and the elements, which can lead to overheating of the elements. Allow large objects to gain heat at a lower temperature and then reset the controller to a temperature close to the desired maximum.

When heating materials which produce smoke or fumes, the chimney must be correctly fitted and unobstructed. Otherwise, soot can accumulate in the chamber and could possibly cause an electrical breakdown of the heating element.

If the furnace is used to heat materials which emit smoke or fumes, regularly heat it up to maximum temperature for one hour without load to burn away the soot.

Materials such as case hardening compounds and other reactive salts may penetrate the furnace chamber lining and attack the wire elements, causing premature failure. Use of a hearth tile may be advisable: please consult our technical department.

3.4 Atmospheres

When an optional gas inlet is fitted there is a label near the inlet saying "INERT GAS ONLY". In practice *inert* or *oxidising* gases may be used, but not combustible or toxic gases. Chamber furnaces are not gas tight, so it should be understood that gas usage may be high, and that the chamber is likely always to contain some air. Residual oxygen levels of 1% may be expected.

3.5 Operator Safety

The furnace incorporates a safety switch which interrupts the heating element circuit when the door is opened. This prevents the user touching a live heating element, but also prevents the furnace from heating up if the door is left open.

Avoid burns. Carbolite can supply tongs, face masks, and heat resistant gloves. Before you remove a hot object from the furnace make sure you have a safe place to put it down.

4.0

MAINTENANCE

4.1 General Maintenance

No routine maintenance is required other than removal of soot deposits mentioned in 3.3 and the occasional replacement of consumable items.

The furnace outer surface may be cleaned with a damp cloth. Do not allow water to enter the interior of the case or chamber. Do not clean with organic solvents.

4.2 Calibration

After prolonged use the controller and/or thermocouple could require recalibration. This would be important for processes which require accurate temperature readings or which use the furnace close to its maximum temperature. A quick check using an independent thermocouple and temperature indicator should be made from time to time to determine whether full calibration is required. Carbolite can supply these items.

Depending on the controller, the controller manual may contain calibration instructions.

4.3 After Sales Service

Carbolite's service division (Thermal Engineering Services) has a team of Service Engineers capable of repair, calibration and preventive maintenance of furnace and oven products at our customers' premises throughout the world. We also sell spares by mail order. A telephone call or fax often enables a fault to be diagnosed and the necessary spare part despatched.

Each furnace has its own record card at Carbolite. In all correspondence please quote the serial number, model type and voltage given on the rating label of the furnace. The serial number and model type are also given on the front of this booklet when supplied with a furnace.

To contact Thermal Engineering Services or Carbolite see the back page of this manual.

4.4 Recommended Spares Kits

Carbolite can supply individual spares, or a kit of the items most likely to be required. Ordering a kit in advance can save time in the event of a breakdown. Each kit comprises one thermocouple (OAF 11/2: 1 set), one sheath, one solid state relay, one door insulation piece, and one element or set of elements. Individual spares are also available.

When ordering spares please quote the model details as requested above.

4.5 Power Adjustment

The furnace control system incorporates electronic power limiting, which is used in some models to compensate for voltage to achieve the same power over a range of voltage supplies. In other models the power limit is set to 100% over all common voltages. The power limit parameter OP.Hi may be accessible to the operator, but should not generally be altered.

See section 8.2 for details of power limit settings. DO NOT adjust the power to a level higher than the design level stated: this may cause fuse to blow, and could damage the heating elements.

Occasionally the power limit is set to zero to permit demonstration of the controls without the heating elements taking power. To resume heating the power limit should be reset to its standard value.

5.0

REPAIRS & REPLACEMENTS

5.1 Safety Warning – Disconnection from Supply

Always ensure that the furnace is disconnected from the supply before repair work is carried out.

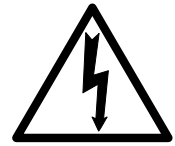

5.2 Safety Note - Refractory Fibrous Insulation

This furnace contains refractory fibres in its thermal insulation. These materials may be in the form of fibre blanket or felt, vacuum formed board or shapes, mineral wool slab or loose fill fibre.



Normal use of the furnace does not result in any significant level of airborne dust from these materials, but much higher levels may be encountered during maintenance or repair.

Whilst there is no evidence of any long term health hazards, we strongly recommend that safety precautions are taken whenever the materials are handled.

Exposure to dust from fibre which has been used at high temperatures may cause respiratory disease.

When handling fibre always use an approved mask, eye protection, gloves and long sleeved clothing.

Avoid breaking up waste material. Dispose of waste fibre in sealed containers.

After handling rinse exposed skin with water before washing gently with soap (not detergent). Wash work clothing separately.

Before commencing any major repairs we recommend reference to the European Ceramic Fibre Industry Association Bulletin No. 11 and the UK Health and Safety Executive Guidance Note EH46.

We can provide further information on request. Alternatively our service division can quote for any repairs to be carried out at your premises or ours.

5.3 Temperature Controller Replacement

201. This controller is fitted to the back of the control panel; in many models this can be separated from the base by removal of two screws.



Before handling the controller: **wear an anti-static wrist strap** or otherwise avoid any possibility of damage to the unit by static electricity.

Refer to the detailed instructions supplied with the replacement controller.

2132, 2416, 2408 etc. Ease apart the two lugs at the side; grip the instrument and withdraw it from its sleeve; push in the replacement.

5.4 Solid-state Relay Replacement

Disconnect the furnace from the supply, and remove the furnace back panel.

Make a note how the wires are connected to the solid state relay, and disconnect them.

Remove the solid state relay from the base panel or aluminium plate.

Replace and reconnect the solid state relay ensuring that the heat-conducting thermal pad is sandwiched between the relay and the base panel or aluminium plate. Alternatively a thin layer of white, heat-conducting silicon paste may be applied between the new relay and the plate.

The new solid state relay contains a built-in MOV which protects it from short periods of excess voltage. If the old relay had a separate disc-shaped "MOV" connected between the high voltage terminals of the old relay, discard the old MOV.

Replace the removed panel

5.5

Thermocouple Replacement

Disconnect the furnace from the supply, and remove the furnace back panel.

Make a note of the thermocouple connections. The negative leg of the thermocouple is marked blue. Compensating cable colour codings are:

<i>Negative</i>	<i>positive (type K)</i>
White	green

Disconnect the thermocouple from its terminal block.

Bend the metal tag, or release the screw, to release the thermocouple sheath, withdraw the sheath, and shake out any fragments of thermocouple.

Re-assemble with a new thermocouple observing the colour coding, ensuring that the thermocouple is not twisted as it is being inserted and that the metal tag is bent back, or the screw inserted, to grip the sheath.

5.6 Element Replacement (AAF 11/3, AAF 11/7, GSM, OAF 11/1)



See section 5.2 - wearing a face mask is recommended.

The chamber of this type of furnace is formed by winding resistance heating wire on to a refractory muffle former. In the event of failure, the whole "wound muffle" assembly must be replaced.

Disconnect the furnace from the supply and remove the furnace back panel. GSM: Pull the chimney out of the top of the furnace.

Make a note of the wiring connections; see the section above which refers to the thermocouple colour coding.

Unfasten the electrical connections to the inner chamber (brick-box) and remove the thermocouple and sheath (see thermocouple replacement instructions). If the connections are secured by hexagonal nuts, two spanners should be used to avoid cracking the porcelain mounting.

Undo any self-tapping screws and hook bolts necessary to release the brick-box.

Support the front of the brick-box as you withdraw it from the case so it does not fall onto the electrical connections below.

Remove the brick-box lid and top insulating board, noting how it is assembled and observing the position of the heating element wires (or "tails").

Pull the element tails out of the terminal block and remove sufficient insulation to allow access to the heating element. Check and replace damaged insulation.

Fit the new heating element, ensuring that the tails are separated from the element by at least 25 mm (preferably 50mm) of insulation – see the picture.

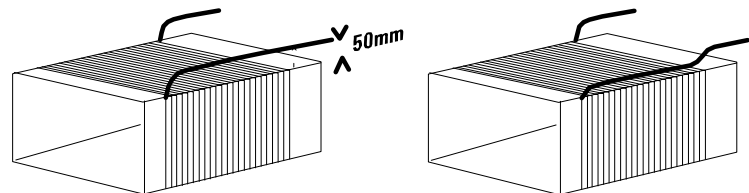

Correct

Incorrect

Feed the element tails through the terminal blocks and tighten the clamping screws using two spanners as before. Cut off excess element tails.

Complete the fitting of the insulation and refit the lid. Do not use any cement unless supplied by Carbolite, as other types may chemically attack the heating element.

Replace and fasten the brick-box into the furnace case.

Replace the thermocouple and sheath and remake the electrical connections. In porcelain and brass terminal blocks the brass connector should be slightly loose in its porcelain support block to allow for expansion.

Replace the back panel and reconnect the electrical supply.

Switch the furnace ON and heat to 900°C without interruption, and then soak for 1 hour. Some smoke may be observed during this process, which should be carried out in a well ventilated area.

Check that the furnace is controlling properly to rule out the possibility that previous element failed because of a fault in the control circuit.

5.7 **Panel Element Replacement (AAF 11/18)**



See section 5.2 - wearing a face mask is recommended.

The chambers have two side-mounted refractory panels in which coiled heating elements are inserted, normally out of sight behind silicon carbide chamber walls.

Disconnect the furnace from the supply and remove the furnace back panel.

Make a written plan showing ALL the element and thermocouple connections. It is important to make this plan for each individual furnace.

Disconnect all the element wire tails and thermocouple cables from their terminal blocks.

Straighten all the element tails. Note that these become brittle with use.

Unscrew the screws fixing the metal back piece from the inner chamber and withdraw this part backwards complete with thermocouple(s) and sheath(s).

Withdraw the back insulation piece. Handle with care. Observe the warning on handling of ceramic fibrous insulation – section 5.2.

Remove the Silicon Carbide chamber side walls, then withdraw the old element(s), and insert the new. Note that the ceramic element carriers are in two pieces, front and back: take care when handling them.

Replace the back insulation piece and metal piece together with the thermocouple(s) and sheath(s).

As necessary, shorten the element tails by clipping to length.

Remake all the thermocouple and element connections according to the individual plan.

Refit the back panel and run the furnace for 30 minutes at 800°C without interruption to ensure complete burn-off of any organic binders. Some smoke may be observed during this process, which should be carried out in a well ventilated area.

Check that the furnace is controlling properly to rule out the possibility that previous element failed because of a fault elsewhere in the control circuit.

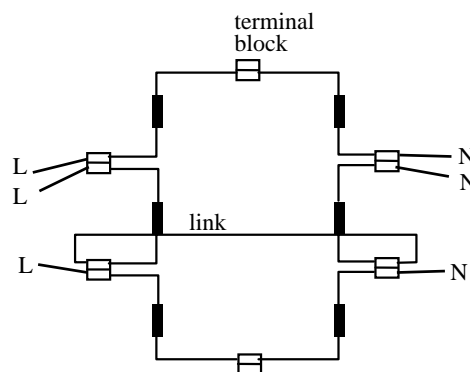

5.8

AAF 11/18 element connection example
(1-phase 200-240V)

Slab Element Replacement (OAF 11/2)



See section 5.2 - wearing a face mask is recommended.

The twin chamber contains two slab elements which form the heated floors of the upper and lower sections. The elements are made of refractory cement in which coiled heating wires are embedded.

Disconnect the furnace from the electrical supply. Remove the furnace back panel and make a simple drawing of how the wires are connected to the elements.

Release the screws which secure the element terminal blocks on the faulty elements. (Element tails become brittle with use, so care must be taken during removal, unless you intend to replace them all.)

Open the furnace door. With a hacksaw blade cut grooves in the front brick sides sufficient only to enable the elements to slide out forwards. Remove the elements and tidy these grooves with a file.

Check the condition of the insulation adjacent to the faulty element(s). Replace the insulation if it is excessively cracked or has radically changed colour or texture.

Slide in the new element(s). Guide the tails through the existing holes in the insulation and reconnect the element terminal blocks.

Cut off any excess tail wire, replace the back panel and reconnect the electrical supply.

Switch the furnace ON and heat to 900°C without interruption, then soak for 1 hour.

Check that the furnace is controlling properly to rule out the possibility that the previous element failed because of a fault elsewhere in the control circuit.

5.9



VMF 10/6 Element Replacement

See section 5.2 - wearing a face mask is recommended.

The heating elements are vacuum formed modules; they are fragile, so spare elements are supplied complete in an insulation box to avoid damage.

Disconnect the furnace, remove the back panel, make a plan of all the internal connections to the back of the heating chamber and disconnect. Remove the thermocouple(s) and support tube(s).

Using a socket spanner undo the four bolts that fasten the insulation box. These are located under the insulation box in the two cross supports.

Remove the insulation box by carefully sliding it out through the back of the furnace case.

Carefully slide in the new insulation box, and fasten the four bolts. DO NOT support the element by putting your hand inside the chamber – the element is fragile.

As necessary, shorten the element tails by clipping to length. Remake all the thermocouple and element connections according to the individual plan.

Refit the back panel and run the furnace for 30 minutes at 800°C without interruption to ensure complete burn-off of any organic binders. Some smoke may be observed during this process, which should be carried out in a well ventilated area.

Check that the furnace is controlling properly to rule out the possibility that the previous element failed because of a fault elsewhere in the control circuit.

5.10

Door Plug Replacement

Lift the furnace door to the open position and remove the door cover from the plug carrier assembly.

Remove the old door plug by sliding it upwards out of its carrier.

Slide the new plug into the carrier assembly making sure that the plug is the correct way up.

Refit the door cover.

When first heating the furnace after a replacement, ensure that the ventilation is good: emission of some fumes may be expected.

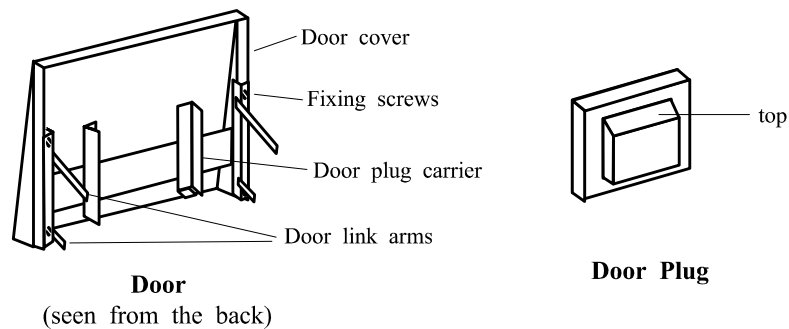

5.11 Fuse Replacement

Fuses are marked on the circuit diagram (section 7.0) with type codes, e.g. F1, F2. A list of the correct fuses is given in section 8.1. *Depending on model and voltage, the different fuse types may or may not be fitted.*

If any fuse has failed, it is advisable for an electrician to check the internal circuits.

Replace any failed fuses with the correct type. For safety reasons do not fit larger capacity fuses without first consulting Carbolite.

The fuses are near the cable entry point, and access is by removal of the back panel.

6.0

FAULT ANALYSIS

A. Furnace Does Not Heat Up

- | | | | |
|----|-------------------------------------|--|--|
| 1. | The HEAT light is ON | → The heating element has failed | → Check also that the SSR is working correctly |
| 2. | The HEAT light is OFF | The controller shows a very high temperature or a code such as S.br | → The thermocouple has broken or has a wiring fault |
| | | The controller shows a low temperature | → The door switch(es) (if fitted) may be faulty or need adjustment |
| | | | → The contactor (if fitted) may be faulty |
| | | | → The SSR could be failing to switch on due to internal failure, faulty logic wiring from the controller, or faulty controller |
| | | There are no lights glowing on the controller | → The SUPPLY light is ON → The controller may be faulty or not receiving a supply due to a faulty switch or a wiring fault |
| | | | → The SUPPLY light is OFF → Check the supply fuses and any fuses in the furnace control compartment |

B. Furnace Overheats

- | | | | |
|----|---|---|--|
| 1. | The HEAT light goes OFF with the instrument switch | → The controller shows a very high temperature | → The controller is faulty |
| | | → The controller shows a low temperature | → The thermocouple may have been shorted out or may have been moved out of the heating chamber |
| | | | → The thermocouple may be mounted the wrong way round |
| | | | → The controller may be faulty |
| 2. | The HEAT light does not go off with the instrument switch | → The SSR has failed “ON” | → Check for an accidental wiring fault which could have overloaded the SSR |

CIRCUIT DIAGRAMS

Safety switches type A: two Door Switches in the element circuit in models up to 25A rating.
 Safety Switch type B: a single Door Switch in the contactor coiled circuit in models over 25A.

7.1 AAF, VMF, GSM or OAF 11/1 single phase

for AAF 11/18 see diagram 7.4

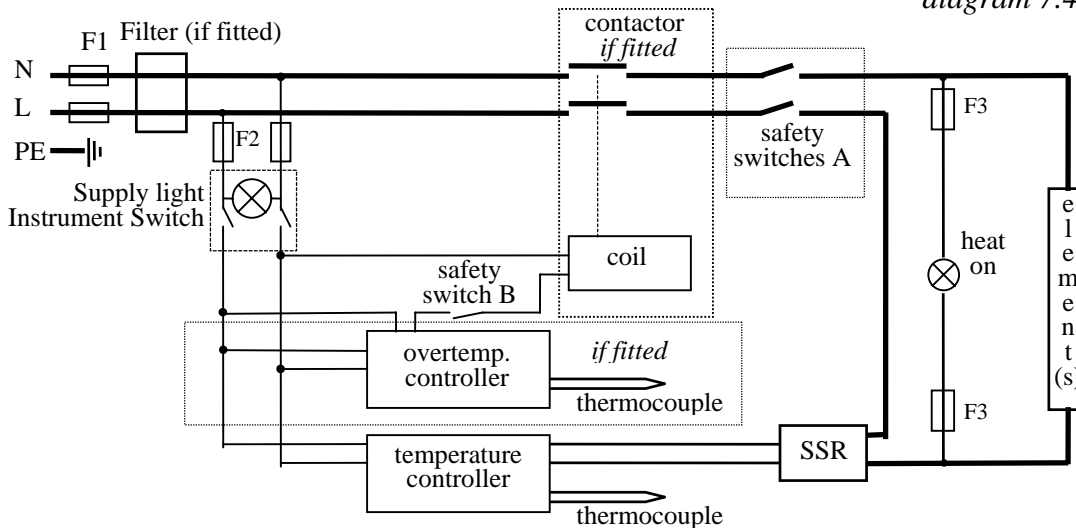

7.2 OAF 11/2 single phase

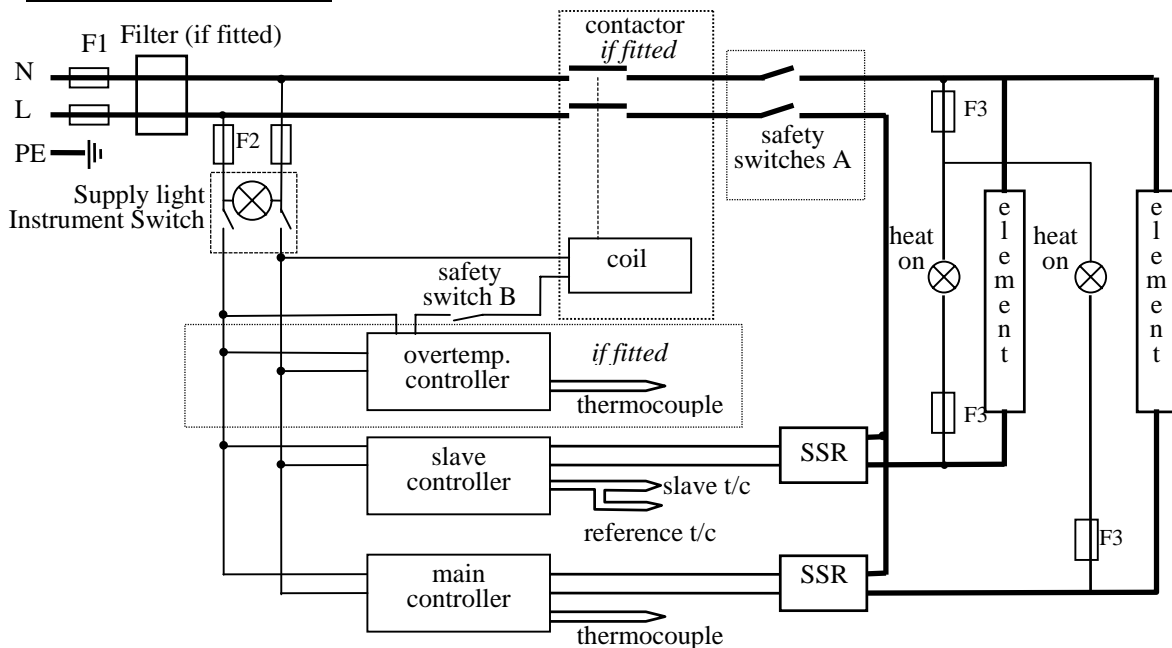

7.3 Higher Voltages (e.g. 254V)

For single phase models of 254V or above, a control circuit transformer is included as follows:

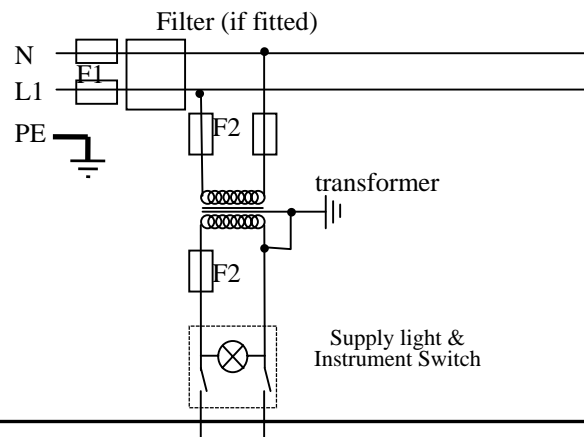

7.4

3-phase “universal” wiring

Applies only to AAF 11/18

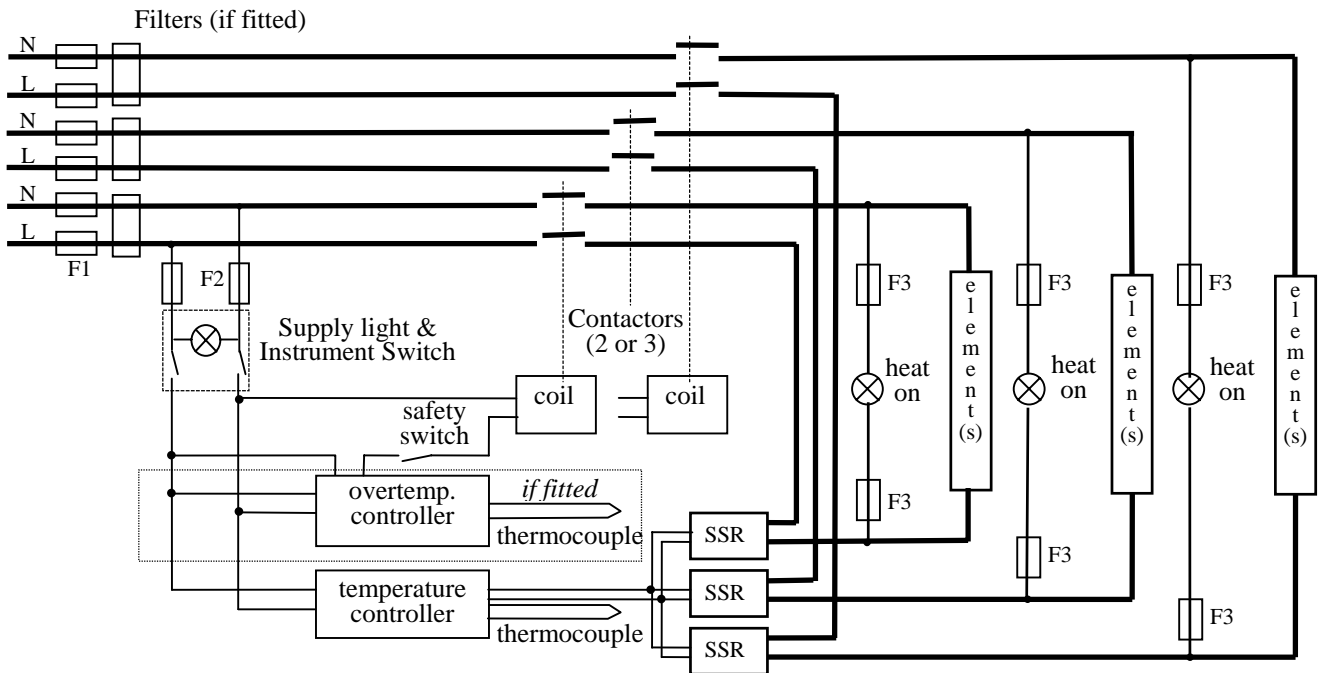

Fuses F1 are always present in this wiring design.

Fuses F2 could be absent in some circumstances, if the circuit does not exceed 10A.

Fuses F3 are present if the circuit exceeds 25A, but otherwise are usually absent.

3-phase + neutral

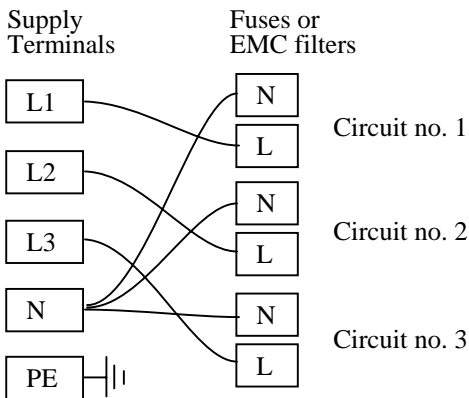

3-phase delta

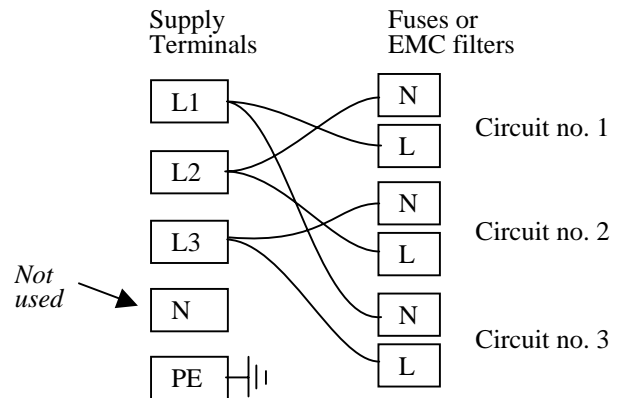

1-phase

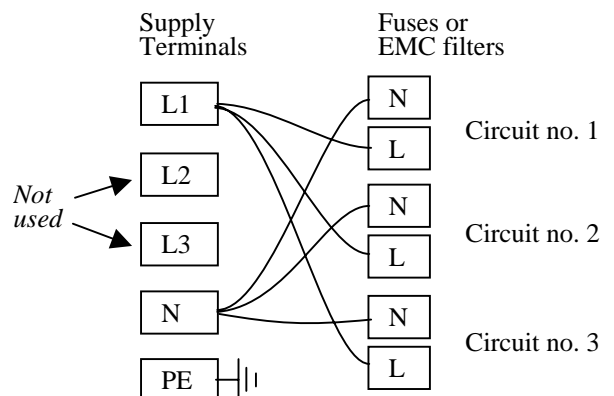

A model made to this diagram can be converted by the customer between the following supply voltages:

between 3-phase + neutral in the range 380/220V – 415/240V

and 3-phase delta in the range 220V – 240V

and single phase in the range 220V – 240V

208V model: convertible from 208V delta to 208V 1-phase

7.5 2-phase models

The OAF models can be made for use on 2 phases of a 3-phase plus neutral supply. If a diagram is required please contact Carbolite.

8.0 FUSES & POWER SETTINGS

8.1 Fuses

F1-F3: Refer to the circuit diagrams.

<i>F1</i>	Internal supply fuses	Fitted if supply cable fitted. Fitted on board to some types of EMC filter.	on-board and up to 16 Amps: 32mm x 6mm type F other: GEC Safeclip
<i>F2</i>	Auxiliary circuit fuses	Fitted on board to some types of EMC filter. May be omitted up to 25Amp/phase supply rating.	2 Amps glass type F On board: 20mm x 5mm Other: 32mm x 6mm
<i>F3</i>	Heat Light fuses	May be omitted up to 25 Amp/phase supply rating.	2 Amps glass type F 32mm x 6mm
	Customer fuses	Required if no supply cable fitted. Recommended if cable fitted.	See rating label for amperage; see table below for fuse rating.

Model	Phases	Volts	Supply Fuse rating
AAF 11/3	1-phase	200-240	10A
AAF 11/7 and OAF 11/1	1-phase	220-240	20A
	1-phase	110-120	40A
	2-phase+N	380/220-415/240	10A per phase
AAF 11/18	1-phase	220-240	30A
	1-phase	200-208	40A
	3-phase+N	380/220-415/240	12.5A per phase
	3-phase delta	220-240	20A per phase
	3-phase delta	200-208	25A per phase
OAF 11/2	1-phase	220-240	20A
	2-phase+N	380/220-415/240	10A per phase
GSM 11/8	1-phase	220-240	12.5A
	1-phase	110-120	25A
VMF 10/6	1-phase	220-240	1-phase 12.5A

8.2 Power Settings

The settings of the power limit parameter OP.Hi are as follows.

model	volts:	200	208	220, 280	230, 400	240, 415	254, 440
AAF 11/3		100	98	87	80	73	65
AAF 11/18		100	100	100	100	94	83
all other models		100	100	100	100	100	89

9.0 SPECIFICATIONS

Carbolite reserves the right to change specifications without notice.

9.1 Models Covered by this Manual

MODEL	Max. Temp. (°C)	Max. Power (kW)	Chamber Size (mm)			Heating Elements (l)	Net Weight (kg)
			H	W	D		
<i>Ashing, Burn-off and Coal & Coke Testing Furnaces</i>							
AAF 11/3	1100°C	2.1	85	150	250	Wound muffle	22
AAF 11/7	1100°C	3.9	90	170	445	Wound muffle	63
AAF 11/18	1100°C	7	235	196	400	Concealed wire	70
OAF 11/1	1100°C	3.9	90	170	445	Wound muffle	60
OAF 11/2	1100°C	4.5	2x60	190	400	Slabs (2)	65
GSM 11/8	1100°C	3.0	125	185	345	Wound silica muffle	63
VMF 10/6	1000°C	3.0	100	210	260	Vacuum formed slabs	45

9.2 Environment

The furnaces contain electrical parts and should be stored and used in indoor conditions as follows:

temperature: 5°C - 40°C

relative humidity: maximum 80% up to 31°C decreasing linearly to 50% at 40°C

The products covered in this manual are only a small part of the wide range of ovens, chamber furnaces and tube furnaces manufactured by Carbolite for laboratory and industrial use. For further details of our standard or custom built products please contact us at the address below, or ask your nearest stockist.

For preventive maintenance, repair and calibration of all Furnace and Oven products, please contact:

Thermal Engineering Services

Telephone: UK: 0845 3308035 Int: +44 1433 623335

Fax: UK: 0845 3308036 Int: +44 1433 623336

Email: thermalservice@dial.pipex.com



Carbolite, Parsons Lane, Hope, Hope Valley, S33 6RB, England.

Telephone: (01433) 620011

Int: +44 1433 620011

Facsimile: (01433) 621198

Int: +44 1433 621198

E-mail: enquiry@carbolite.co.uk