



Installation, Operation & Maintenance Instructions

1800°C Vertical Tube Furnaces
PVT Models

This manual is for the guidance of operators of the above Carbolite products and should be read before the furnace is connected to the electricity supply.

CONTENTS

Section		page
1.0	Symbols & Warnings	2
2.0	Installation	3
3.0	Operation	5
4.0	Maintenance	7
5.0	Repairs & Replacements	8
6.0	Fault Analysis	11
7.0	Circuit Diagrams	12
8.0	Fuses & Power Settings	14
9.0	Specifications	16

**Manuals are supplied separately for the furnace controller
(and overtemperature controller when fitted).**

Please read the controller manuals before operating the furnace.



1.0 SYMBOLS & WARNINGS

1.1 Switches and Lights



Supply Light: when the furnace is connected to the electrical supply the light in the adjacent switch glows



Heat Switch: the switch disconnects power to the heating elements; unless this switch is off there is a danger of electric shock when inserting objects into the furnace



Heat Light: the adjacent light glows or flashes to indicate that power is being supplied to the elements

1.2 Warning Symbols

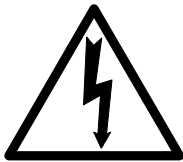

DANGER of electrical shock– read any warning printed by this symbol.



DANGER – hot surface. Read any warning printed by this symbol.
WARNING: all surfaces of a furnace may be hot.



DANGER – read any warning printed by this symbol.

2.0 **INSTALLATION**

2.1 **Unpacking & Handling**

When unpacking or moving the furnace always lift it by its base or stand. Never lift it by its work tube or the surrounding insulation. Use two people or more people to carry the furnace, or use appropriate mechanical equipment. Remove any packing material from inside the furnace before use.

2.2 **Siting**

Place the furnace in a well ventilated area, away from other sources of heat, and on a surface which is resistant to accidental spillage of hot materials. Do not mount the furnace on an inflammable surface.

Ensure that there is free space around the furnace. Do not obstruct any of the vents in the control section: they are needed to keep the controls cool.

Ensure that the furnace is placed in such a way that it can be quickly switched off or disconnected from the electrical supply - see below.

2.3 **Setting Up**

Elements



The lanthanum chromite elements are separately packed. They are expensive and extremely fragile, so care should be taken in handling it. Also, avoid touching the heating surface – heating elements can be damaged by contamination.

Remove the end plates and side panels of the furnace. Sleeves are provided to fit the holes in the insulation where the elements are placed (the upper sleeves may be fitted and the lower supplied loose). Place each element in position and fit its lower sleeve. Secure the elements with the clips provided. Connect the elements using the braids. See 5.3.

Work Tube (if supplied)

The work tube is separately packed. It is expensive: take care in handling it.

The tube is held in place vertically by a ring clip arrangement inside the casing at the bottom of the furnace body.

Remove the side panels and guide the tube into the furnace chamber by carefully lowering it from above. Using the ring clip arrangement fix the tube into position.

Fit any tube accessories supplied. If end seals and radiation shields are provided, note that the seals must not be used without the radiation shields also being fitted.

In this furnace it is extremely inadvisable to use the work tube without an approved form of heat shield at the ends. Carbolite can supply suitable radiation shields for this purpose.

2.4 Electrical Connections

Connection by a qualified electrician is recommended.

The furnaces have one to three internal circuits, depending on model and voltage option. All may be ordered for single phase use; some may be ordered for two phases out of a three phase and neutral supply, and some for a three phase supply.

Check the furnace rating label before connection. The supply voltage should agree with the voltage on the label, and the supply capacity should be sufficient for the amperage on the label.

The supply should be fused at the next size equal to or higher than the amperage on the label. A table of the most common fuse ratings is also given in section 8.1 of this manual. Where a supply cable is present there are internal supply fuses; customer fusing is preferred but not essential.

Furnace with supply cable: either wire directly to an isolator or fitted with a line plug.

Furnace without supply cable: a permanent connection to a fused and isolated supply should be made to the internal terminals after temporary removal of the control box back panel.

Connection by line plug: the plug should be within reach of the operator, and should be quickly removable.

Connection to isolating switch: this should operate on both conductors (single phase) or on all live conductors (two/three phase), and should be within reach of the operator.

The supply MUST incorporate an earth (ground).

CONNECTION DETAILS			<i>supply type</i>	
Supply	Terminal label	Cable colour	<i>Live-Neutral</i>	<i>Reversible or Live-Live</i>
<i>1-phase</i>	L	Brown	To live	to either power conductor
	N	Blue	To neutral	to the other power conductor
	PE	Green/Yellow	To earth (ground)	to earth (ground)
supply	Terminal label	Cable colour		
<i>2- or 3-phase</i>	L1	Black	to phase 1	
	L2	Black	to phase 2	
	L3	Black	to phase 3 <i>except 2-phase</i>	
	N	Light Blue	to neutral <i>except delta</i>	
	PE	Green/Yellow	to earth (ground)	

Technical Notes

The furnaces covered by this manual have electronically controlled power limits. Do not attempt to calculate the Amps from the Wattage. High break capacity fuses should be used. Avoid fast-blow fuses and magnetic trip circuit breakers - consult Carbolite if in doubt.

Two-phase models use two phases out of a 3-phase+neutral supply. One phase is unused. The neutral current is equal to the current in one of the used phases.

3.0 **OPERATION**

The instructions for operating the temperature controller are given in a separate manual.

If the furnace is fitted with a time switch, see also the supplementary manual MS03.

If cascade control is fitted, see the supplementary manual MS07.

3.1 **Operating Cycle**

The furnace is fitted with a combined Supply light and Instrument switch. The light is on whenever the furnace is connected to the supply. The switch cuts off power to the control circuit. There is also a Heater switch which can be used to disconnect power to the elements.

Connect the furnace to the electrical supply. The Supply light should glow.

Operate the instrument switch to activate the temperature controller; the **O** position is *off*, the **I** position *on*. The controller becomes illuminated and goes through a short test cycle.

Adjust the temperature controller (see controller manual).

If the overtemperature controller has not yet been set as required, set it and activate it according to the instructions in the appropriate manual.

Unless a time switch is fitted and is off, the furnace starts to heat up. The Heat light(s) glow steadily at first and then flash as the furnace approaches the desired temperature or a program setpoint.

If the overtemperature trip operates then an indicator in the overtemperature controller flashes, and the heating elements are isolated. Find and correct the cause before resetting the overtemperature controller according to the instructions supplied.

To switch the furnace off, set the Instrument switch to **O**. If the furnace is to be left off, isolate it the electrical supply.

3.2 **General Operating Advice**

Heating element life is shortened by use at temperatures close to maximum. Do not leave the furnace at high temperature when not required. The maximum temperature is shown on the furnace rating label and on the back page of this manual.

3.3 **Operator Safety**



The ceramic materials used in furnace manufacture become electrically conductive to some extent at high temperatures. **DO NOT** use any conductive tools within the work tube without isolating it.

If a metal work tube or work piece is used, it must be earthed (grounded). Note that the furnace temperature should be limited if a metal tube is used.



Ensure that there are no inflammable objects placed in such a way that the work tube could break and fall on them.



Switch off the Heater switch whenever loading or unloading the furnace. The elements are isolated when the Heater switch is OFF. This switch cuts both sides of the circuit directly or via a contactor (a contactor is used in models where the rated current exceeds 16 Amps).

(Note that the heater switch is not fitted in models ordered before May 1999).

3.4 **Tube Life**

A ceramic work tube may crack if workpieces are inserted too quickly or at temperatures below 900°C (when the tube is more brittle). Large pieces should also be heated slowly to ensure that large temperature differences do not arise.

Do not set too high a heating rate. Large diameter tubes are more susceptible to thermal shock than smaller. A general rule for maximum heating rate is 400/internal diameter (°C/min); for 75mm i/d tubes this comes to 5°C per minute. The controller can be set to limit the heating rate.

3.5 Pressure

Work tubes are not able to accept high internal pressure. When gas seals or similar fittings are in use, the gas pressure should be restricted to a maximum of 0.2 bar (3 psi). A pressure of about half of that should normally be sufficient to achieve the desired flow rate. The customer must ensure that the exhaust path from the tube is not blocked, so that excess pressure does not occur.

3.6 Thermocouples - Warning

- (1) The output from 1700-1800°C thermocouples when used regularly at temperatures greater than 1650°C can deteriorate and decrease with age.

Customers are advised periodically to check the thermocouple output, either by a calibration test, or by comparing the output with a new reference thermocouple which has been subjected to high temperatures for a minimum length of time.

Failure to check the thermocouple may result in overheating of the work and the furnace.

- (2) The thermocouples fitted to these models give very low outputs below about 600°C, and do not give accurate readings at low temperatures. The furnaces are not intended to be operated below 600°C.

4.0 MAINTENANCE

4.1 Routine Maintenance

No routine maintenance is required except for the replacement of consumable items as required.

The outer surfaces may be cleaned with a damp cloth. Do not allow water to enter the interior of the case, tube or control box. Do not clean with organic solvents.

4.2 Calibration

After prolonged use the controller and/or thermocouple could require recalibration. This would be important for processes which require accurate temperature readings or which use the furnace close to its maximum temperature. A quick check using an independent thermocouple and temperature indicator should be made from time to time to determine whether full calibration is required. Carbolite can supply these items.

Depending on the controller, the controller manual may contain calibration instructions.

4.3 After Sales Service

Carbolite's service division (Thermal Engineering Services) has a team of Service Engineers capable of repair, calibration and preventive maintenance of furnace and oven products at our customers' premises throughout the world. We also sell spares by mail order. A telephone call or fax often enables a fault to be diagnosed and the necessary spare part despatched.

Each furnace has its own record card at Carbolite. In all correspondence please quote the serial number, model type and voltage given on the rating label of the furnace. The serial number and model type are also given on the front of this booklet when supplied with a furnace.

To contact Thermal Engineering Services or Carbolite see the back page of this manual.

4.4 Recommended Spares Kits

Carbolite can supply individual spares, or a kit of the items most likely to be required. Ordering a kit in advance can save time in the event of a breakdown. Each kit comprises one thermocouple, one sheath, one solid state relay, a set of heating elements, a set of clips and a set of braids. Individual spares are also available.

When ordering spares please quote the model details as requested above.

4.5 Power Adjustment

The furnace control system incorporates electronic power limiting. Power is supplied to the elements in bursts of about 1/3rd second duration. This prevents overheating of the elements. The power limit is programmed into the furnace controller and may be calculated as a percentage as follows:

$$\text{powerlimit} = (100 \times \text{targetpower} \times \text{ohms}) / \text{volts}^2$$

where targetpower is the wattage given on the furnace rating label

ohms is the overall resistance of the combined element circuits (see example)

volts is the voltage across each element circuit (e.g. 240 for a 415/240V supply)

example:

1-phase furnace with 6 elements of 4.6 ohms each, 3 in series parallel with 3 in series, running on 380/220V, with a target power of 6000W:

$$\text{ohms} = 4.6 \times 3/2 = 6.9$$

$$\text{powerlimit} = (100 \times 6000 \times 6.9) / (220 \times 220) = 85\%$$

A table of power limit settings is given in section 8.2. These are the settings for the furnace with new elements as supplied.

5.0 REPAIRS & REPLACEMENTS

5.1 Safety Warning – Disconnection from Supply

Always ensure that the furnace is disconnected from the supply before repair work is carried out.



5.2 Safety Note - Refractory Fibrous Insulation

This furnace contains refractory fibres in its thermal insulation. These materials may be in the form of fibre blanket or felt, vacuum formed board or shapes, mineral wool slab or loose fill fibre.



Normal use of the furnace does not result in any significant level of airborne dust from these materials, but much higher levels may be encountered during maintenance or repair.

Whilst there is no evidence of any long term health hazards, we strongly recommend that safety precautions are taken whenever the materials are handled.

Exposure to dust from fibre which has been used at high temperatures may cause respiratory disease.

When handling fibre always use an approved mask, eye protection, gloves and long sleeved clothing.

Avoid breaking up waste material. Dispose of waste fibre in sealed containers.

After handling rinse exposed skin with water before washing gently with soap (not detergent). Wash work clothing separately.

Before commencing any major repairs we recommend reference to the European Ceramic Fibre Industry Association Bulletin No. 11 and the UK Health and Safety Executive Guidance Note EH46.

We can provide further information on request. Alternatively our service division can quote for any repairs to be carried out at your premises or ours.

5.3 Element Fitting and Replacement

Disconnect the furnace from the electrical supply. Remove the end plates and side panels of the furnace.

Remember that the elements are fragile and expensive, and that they can be damaged by contamination: handle them with care and keep them clean.

Refer to the diagrams on page

Replacements: make a note of the actual braid and cable connections to the elements. Disconnect the clips with the special tool provided (or with finger pressure, depending on the type of clip fitted). Remove the braids.

Unscrew the retaining ring clip from the bottom collar and remove the collar. Temporarily support the element at the bottom. Remove the top collar, and carefully withdraw the element.

Carefully insert the new elements into the furnace. Ensure that the elements are placed such that the same length is outside the insulation at each end. Refit the retaining collars.

Attach the braids according to the notes made, or according to the appropriate diagram. Use the special tools (or finger pressure) to fit the clips. Take care that clips do not touch each other or any other metal parts.

Replace the panels and connect the furnace to the supply.

If you have any problems with this procedure, please contact our service division.

Element clips and retaining collars

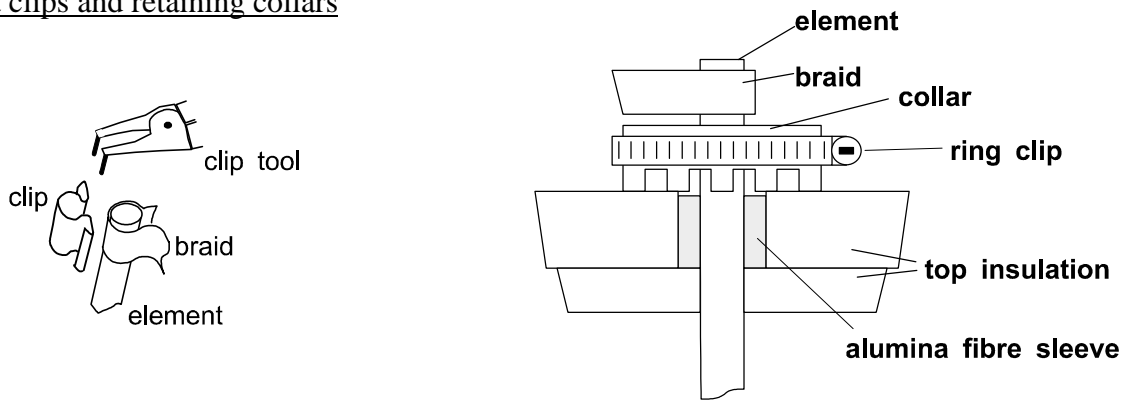

Braid connections – PVT 18/50/200

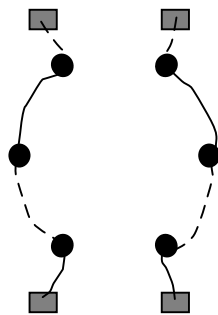

Braid connections – PVT 18/785/350 or similar

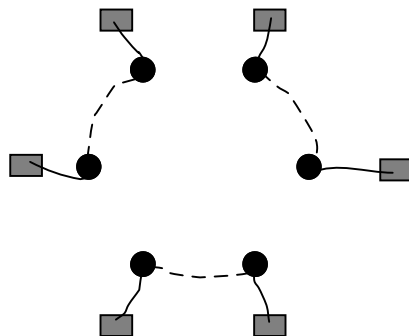

Legend

- element
- terminal block
- braid – on top
- - - braid – on bottom

5.4 Fuse Replacement

Fuses are marked on the circuit diagram (section 7.0) with type codes, e.g. F1, F2. A list of the correct fuses is given in section 8.1. *Depending on model and voltage, the different fuse types may or may not be fitted.*

If any fuse has failed, it is advisable for an electrician to check the internal circuits. Replace any failed fuses with the correct type. For safety reasons do not fit larger capacity fuses without first consulting Carbolite.

The fuses are near the cable entry point, and access is by removal of the control box back panel.

5.5 Temperature Controller Replacement

201. These controllers are fitted to the back of the control panel, which can be separated from the base by removal of two screws.



Before handling the controller: **wear an anti-static wrist strap** or otherwise avoid any possibility of damage to the unit by static electricity.

Refer to the detailed instructions supplied with the replacement controller.

2132, 2416, 2408 etc. Ease apart the two lugs at the side; grip the instrument and withdraw it from its sleeve; push in the replacement.

5.6 Solid-state Relay Replacement

Disconnect the furnace from the supply and remove the back panel from the control box..

Make a note of how the wires are connected to the solid state relay, and disconnect them. Remove the solid state relay from the base panel or aluminium plate.

Replace and reconnect the solid state relay ensuring that the heat-conducting thermal pad is sandwiched between the relay and the base panel or aluminium plate. Alternatively a thin layer of white, heat-conducting silicon paste may be applied between the new relay and the plate.

The solid state relay contains a built-in MOV which protects it from short periods of excess voltage. *Older models only:* If the old relay had a separate disc-shaped "MOV" connected between the high voltage terminals of the old relay, discard the old MOV.

Replace the removed panel.

5.7 Thermocouple Replacement

Disconnect the furnace from the supply, and remove the side panels required to gain access to the thermocouple connections.

Make a note of the thermocouple connections. The negative leg of the thermocouple is marked blue.

Disconnect the thermocouple from its terminal block.

Withdraw the thermocouple from its sheath and remove any broken bits of thermocouple. Alternatively, withdraw the sheath together with the thermocouple, first disconnecting any screws which hold the sheath in place.

Insert the new thermocouple (or thermocouple and sheath) into position, restoring any removed porcelain spacers, and ensuring correct polarity.

Re-assemble the furnace.

6.0 FAULT ANALYSIS

A. Furnace Does Not Heat Up

- | | | | |
|----|-------------------------------------|--|--|
| 1. | The HEAT light is ON | → The heating element has failed | → Check also that the SSR is working correctly |
| 2. | The HEAT light is OFF | The controller shows a very high temperature or a code such as S.br | → The thermocouple has broken or has a wiring fault |
| | | The controller shows a low temperature | → The door switch(es) (if fitted) may be faulty or need adjustment |
| | | | → The contactor (if fitted) may be faulty |
| | | | → The SSR could be failing to switch on due to internal failure, faulty logic wiring from the controller, or faulty controller |
| | | There are no lights glowing on the controller | → The SUPPLY light is ON → The controller may be faulty or not receiving a supply due to a faulty switch or a wiring fault |
| | | | → The SUPPLY light is OFF → Check the supply fuses and any fuses in the furnace control compartment |

B. Furnace Overheats

- | | | | |
|----|---|---|--|
| 1. | The HEAT light goes OFF with the instrument switch | → The controller shows a very high temperature | → The controller is faulty |
| | | → The controller shows a low temperature | → The thermocouple may have been shorted out or may have been moved out of the heating chamber |
| | | | → The thermocouple may be mounted the wrong way round |
| | | | → The controller may be faulty |
| 2. | The HEAT light does not go off with the instrument switch | → The SSR has failed “ON” | → Check for an accidental wiring fault which could have overloaded the SSR |

7.0 CIRCUIT DIAGRAMS

EMC Filters (if fitted): dependent on the model there may be one filter, or more than one fitted in parallel. The circuit diagram examples do not show multiple filter arrangements.

7.1 Single Phase

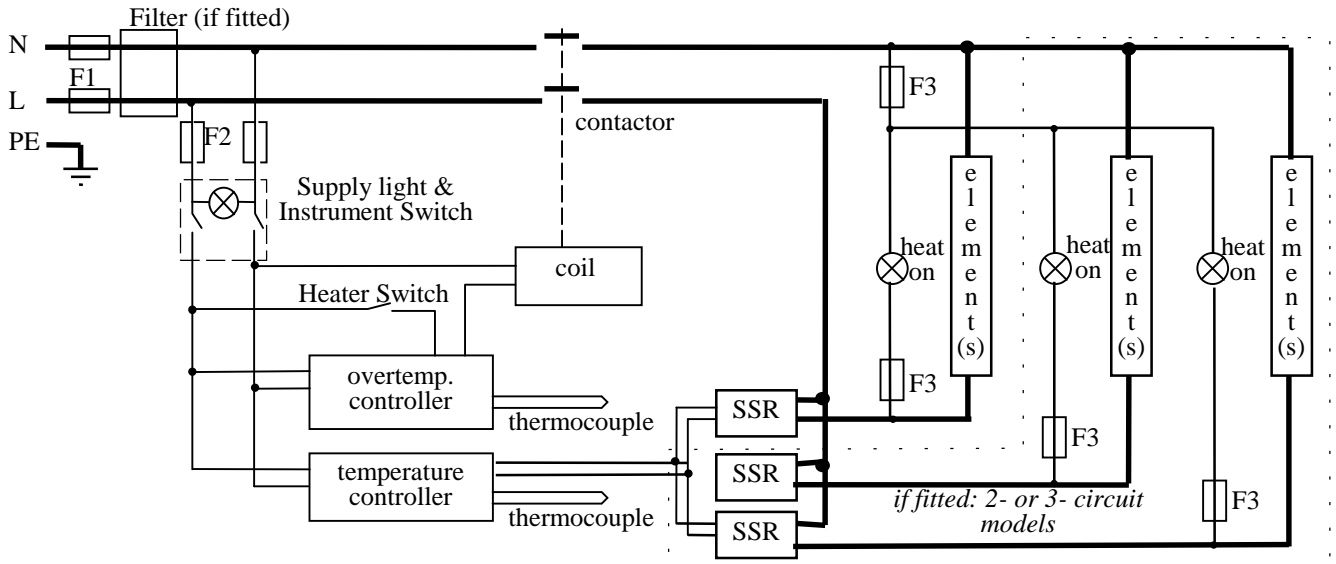

7.2 2-phase with neutral

As the following 3-phase diagram, except that one phase is not present.

Note that if the phase current is less than 25A/phase, a direct safety switches may be fitted in the element circuit, rather than the switch shown in the coil circuit.

7.3 3-phase with neutral

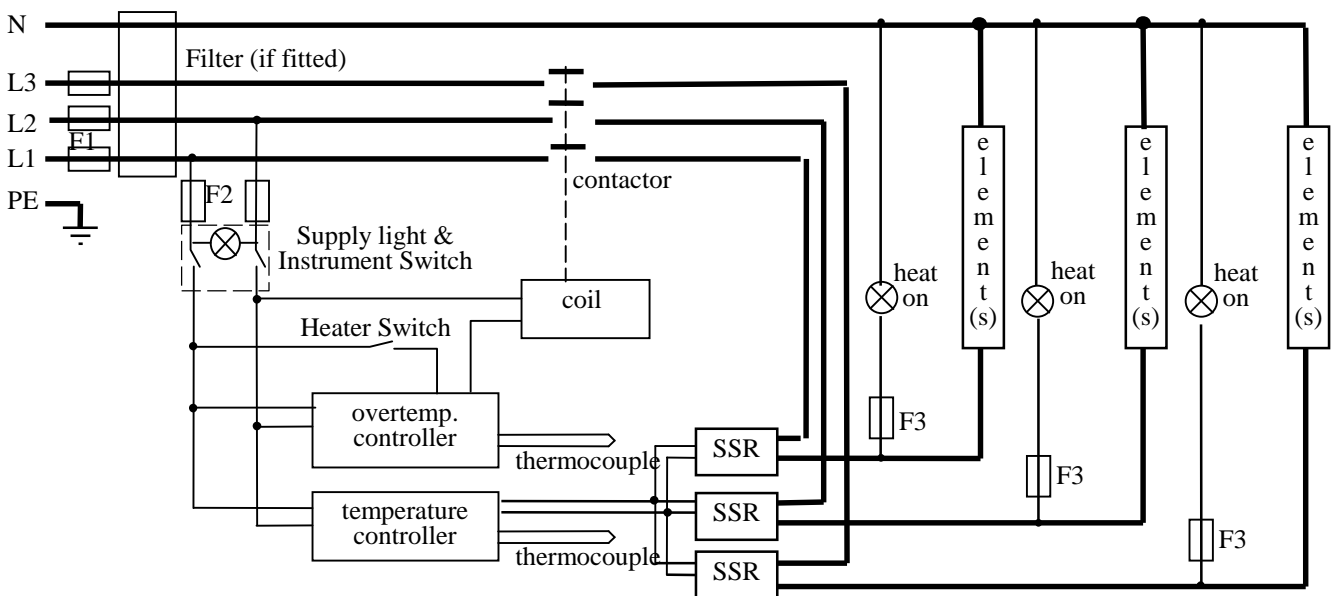

note on (2- and) 3-phase: depending on filter(s) fitted, there may be (2 or) 3 separate neutral wires from the elements to the neutral supply.

7.4 3-phase without neutral (delta – 208 to 240V)

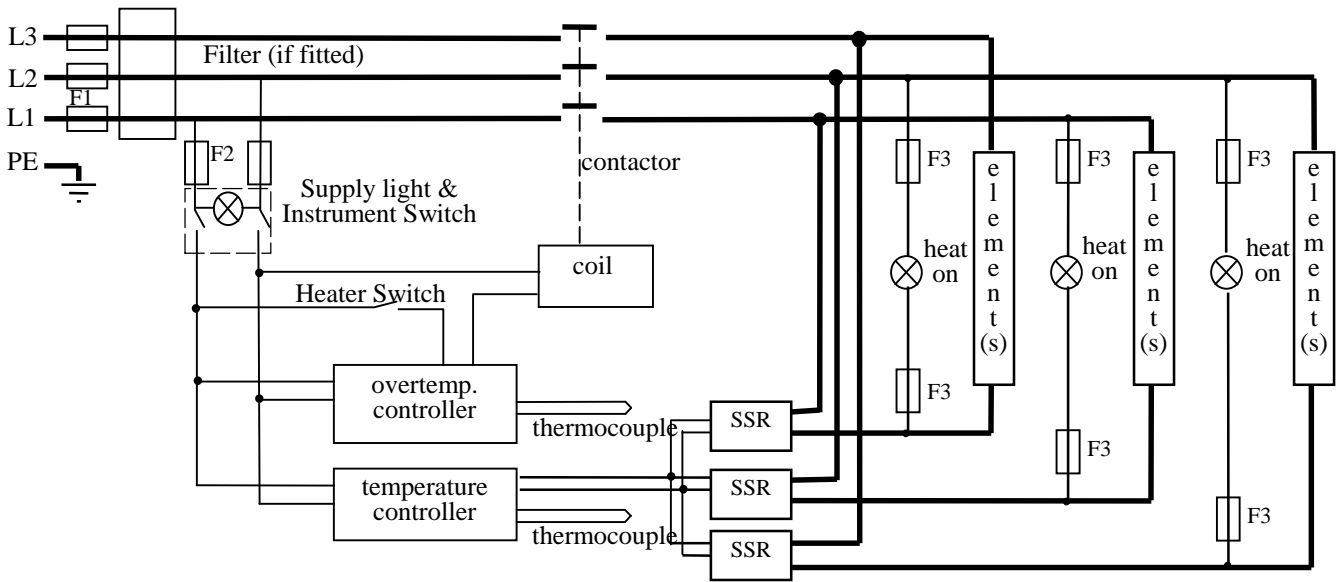

7.5 3-phase without neutral (star – e.g. 380 to 415V)

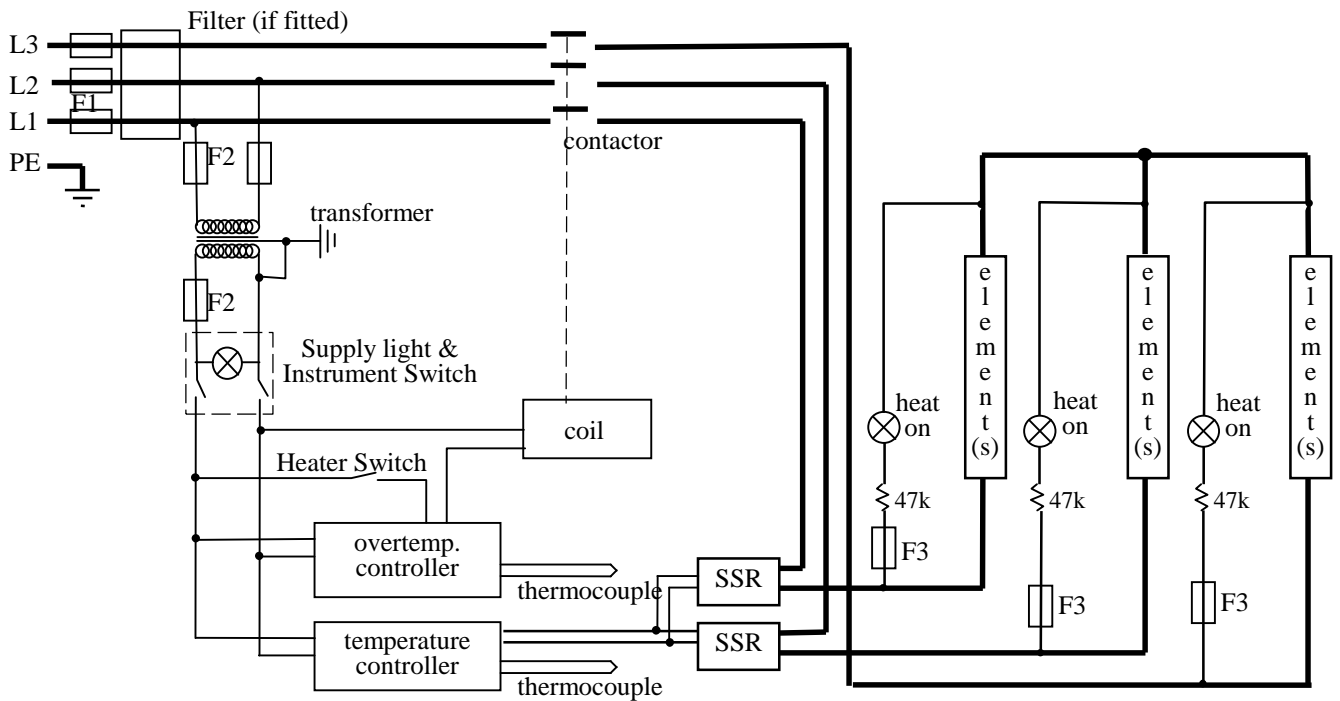

Note: in this configuration the fuses F2 on the supply side of the transformer may be GEC Safeclip, not 32 x 6mm glass as stated in section 8.1.

7.6 Higher Voltages (e.g. 440V, 480V 3-phase)

The diagram above (7.5) normally applies, with neutral (if present) not being used.

For single phase models of 254V or above, diagram 7.1 applies except that a control circuit transformer is included as in diagram 7.4.

8.0 FUSES & POWER SETTINGS

8.1 Fuses *F1-F3: Refer to the circuit diagrams.*

<i>F1</i>	Internal supply fuses	Fitted if supply cable fitted. Fitted on board to some types of EMC filter.	on-board and up to 16 Amps: 32mm x 6mm type F other: GEC Safeclip
<i>F2</i>	Auxiliary circuit fuses	Fitted on board to some types of EMC filter.	2 Amps glass type F On board: 20mm x 5mm Other: 32mm x 6mm
<i>F3</i>	Heat Light fuses	May be omitted up to 25 Amp/phase supply rating.	2 Amps glass type F 32mm x 6mm
	Customer fuses	Required if no supply cable fitted. Recommended if cable fitted.	See rating label for amperage; see table below for fuse rating.

Table of Supply Fuse Ratings:

		Single phase					2-phase+N		
Model	Volts:	200V	208V	220V	230V	240V	380V	400V	415V
PVT 18/50/200		30A	32A	32A	32A	32A	16A	16A	16A
PVT 18/75/350		50A	50A	50A	50A	50A			
PVT 18/100/350									
PVT 18/125/350		80A	80A	80A	80A	80A			
		3-phase delta					3-phase+N		
Model	Volts:	200V	208V	220V	230V	240V	380V	400V	415V
PVT 18/75/350		25A	25A	25A	25A	25A	15-16A	15-16A	15-16A
PVT 18/100/350									
PVT 18/125/350		50A	50A	50A	50A	50A	25A	25A	25A

8.2 Power Settings

The power limit settings (parameter ΔPH_i) for the various models and supply voltages are as follows. The figures represent the maximum percentage of time that controlled power is supplied to the elements. Do not attempt to “improve performance” by setting a value higher than the correct one from the table.

	Single phase					2-phase+N		
Model Volts:	200V	208V	220V	230V	240V	380V	400V	415V
PVT 18/50/200	100	95	85	78	71	85	78	71
PVT 18/75/350	95	87	79	72	66			
PVT 18/100/350								
PVT 18/125/350	72	66	59	54	50			
	3-phase delta					3-phase+N		
Model Volts:	200V	208V	220V	230V	240V	380V	400V	415V
PVT 18/75/350	95	87	79	72	66	79	72	66
PVT 18/100/350								
PVT 18/125/350	72	66	59	54	50	59	54	50

9.0 SPECIFICATIONS

Carbolite reserves the right to change specifications without notice.

9.1 Models Covered by this Manual

MODEL	Max. Temp. (°C)	Max. Power (kW)	Work Tube Bore (mm)	Work Tube Length (mm)	Heated Length (mm)	Net Weight (kg)
<i>Tube furnaces heated by Silicon Carbide elements</i>						
PVT 18/50/200	1800°C	6	50	1200	200	250+
PVT 18/75/350	1800°C	8	75	1200	350	250+
PVT 18/100/350	1800°C	8	100	1200	350	250+
PVT 18/125/350	1800°C	12	125	1200	350	250+

9.2 Environment

The furnaces contain electrical parts and should be stored and used in indoor conditions as follows:

temperature: 5°C - 40°C

relative humidity: maximum 80% up to 31°C decreasing linearly to 50% at 40°C

The products covered in this manual are only a small part of the wide range of ovens, chamber furnaces and tube furnaces manufactured by Carbolite for laboratory and industrial use. For further details of our standard or custom built products please contact us at the address below, or ask your nearest stockist.

For preventive maintenance, repair and calibration of all Furnace and Oven products, please contact:

Thermal Engineering Services

Telephone: UK: 0845 3308035 Int: +44 1433 623335
Fax: UK: 0845 3308036 Int: +44 1433 623336
Email: service@thermalservice.com



MF41-3.01

4/10/00

PVT

Carbolite, Parsons Lane, Hope,
Hope Valley, S33 6RB, England.
Telephone: (01433) 620011
Int: +44 1433 620011
Facsimile: (01433) 621198
Int: +44 1433 621198
E-mail: info@carbolite.com