



General Features

- Laboratory scale rotary batch furnace provides agitation of powdered solids under controlled atmosphere and temperature environment.
- Maximum operating temperature of 1100°C.
- Designed to simulate larger industrial rotary calcining processes in a laboratory size furnace.
- Continuous agitation of material overcomes the problems of long reaction times experienced by static processing in a box or tube furnace.
- The material is retained and heated in an enlarged vessel section of a quartz tube.
- Furnace is available in two sizes measured by the quartz vessel diameter and length. (See specification chart)
- A typical charge for the furnace would be moderately fine to coarse granular solids which do not contain significant quantities of dust.
- The smooth internal vessel profile allows convenient loading, emptying and cleaning with minimum powder loss.
- Hinged heated chamber design provides easy access for removal and insertion of the quartz vessel.
- A long-life resistance wire heating element is combined with low thermal mass insulation to provide an efficient uniform heated chamber.
- The quartz vessel will rotate in one direction 315°, and then reverse its rotation 315°.
- Quartz vessel rotation is variable through adjustment of panel mounted speed control.
- Quartz vessel is fluted on the internal surface to insure good mixing and uniform exposure of particles to the atmosphere.
- Furnace is provided with a nitrogen flow meter, with alternate gas and additional flowmeters available as options.
- Outlet end of quartz vessel extends into stainless steel exhaust box that is fitted with gas outlet port.
- Positive break furnace safety switch isolates power to the heating elements when the furnace is opened.
- Controls are built into furnace cabinetry, providing convenient observation and access to all power and temperature controls.
- Choice of Model 301 control or programmers.



HTR 11/75/3216P1

Rotary Tube Furnaces

Carbolite can provide continuous or batch rotary tube furnaces specifically designed to a customer's process requirement. The general design concept of such rotary tube furnaces is similar, but furnace and system specifications will vary based on process temperature, throughput, atmosphere requirements, characteristics of material, cooling requirements, etc. Please contact Carbolite to discuss your rotary tube furnace requirement.

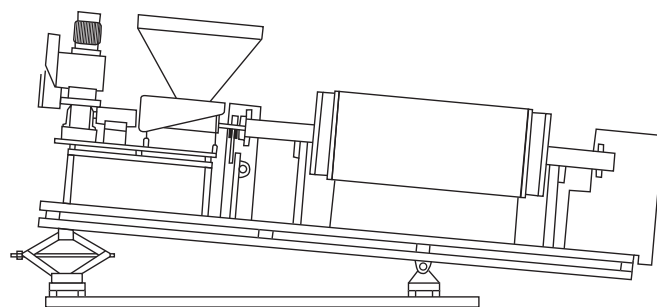

1100°C Rotary Reactor Furnaces

Furnace Model	Max. Temp. (°C)	Vessel Size Inches (mm)		Vessel Volume* (liters)	TC Type	Max. Power (kW)	Furnace Voltage	External Dimensions Inches (mm)			Shipping Weight (lb.)
		Diameter	Length					Height	Length	Depth	
HTR 11/75	1100	3.00 (75)	4.00 (100)	.06 to .08	K	1.5	208/240	19.00 (480)	45.00 (1140)	21.75 (550)	194
HTR 11/150	1100	6.00 (150)	8.00 (200)	.7 to .9	K	3.0	208/240	21.25 (540)	51.25 (1300)	27.25 (690)	296

*Specific volume may be affected by material specifications and flow characteristics.

Specify voltage at time of order.
Furnaces operate on single phase voltage.