



Installation, Operation & Maintenance Instructions

1100°C - 1300°C Chamber Furnaces
types CWF, BWF & RWF

This manual is for the guidance of operators of the above Carbolite products and should be read before the furnace is connected to the electricity supply.

CONTENTS

Section		page
1.0	Symbols & Warnings	2
2.0	Installation	3
3.0	Operation	5
4.0	Maintenance	7
5.0	Repairs & Replacements	8
6.0	Fault Analysis	11
7.0	Circuit Diagrams	12
8.0	Fuses & Power Settings	15
9.0	Specifications	16

**Manuals are supplied separately for the furnace controller
(and overtemperature controller when fitted).**

Please read the controller manuals before operating the furnace.



1.0 SYMBOLS & WARNINGS

1.1 Switches and Lights



Supply Light: when the furnace is connected to the electrical supply the light in the adjacent switch glows

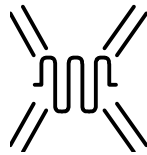

Heat Light: the adjacent light glows or flashes to indicate that power is being supplied to the elements

1.2 Warning Symbols

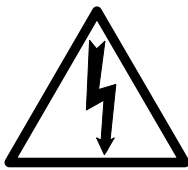

DANGER of electrical shock– read any warning printed by this symbol.



DANGER – hot surface. Read any warning printed by this symbol.
WARNING: all surfaces of a furnace may be hot.



DANGER – read any warning printed by this symbol.

2.0 INSTALLATION

2.1 Unpacking & Handling

When unpacking or moving the furnace always lift it by its base. Never lift it by the door. Use two people to carry the furnace where possible.

Remove any packing material from the door gear and furnace chamber before use.

2.2 Siting & Setting Up

Place the furnace in a well ventilated room, away from other sources of heat, and on a surface which is resistant to accidental spillage of hot materials. Do not mount the furnace on an inflammable surface.

Ensure that there is free space around the furnace. Do not obstruct any of the vents in the control section: they are needed to keep the controls cool.

Ensure that the furnace is placed in such a way that it can be quickly switched off or disconnected from the electrical supply - see below.

If the chimney is supplied unfitted, then fit it into the hole in the top of the furnace case.

If the furnace is to be used to heat substances which emit fumes, then a fume extraction duct of about 150mm inlet diameter may be placed directly above the chimney outlet. Do not make a sealed connection to the furnace chimney as this causes excessive airflow through the chamber and results in poor temperature uniformity.

2.3 Electrical Connections

Connection by a qualified electrician is recommended

All furnaces covered by this manual may be ordered for single phase A.C. supply, which may be Live to Neutral non-reversible, Live to Neutral reversible or Live to Live.

The 23 litre models can also be supplied for three phase use: they must only be connected to the correct type of supply (star or delta at the correct phase to phase voltage). RWF /13 models (and by special order the CWF & BWF /13) can be supplied for use on two phases out of a three phase with neutral supply, leaving one phase unused.

Check the furnace rating label before connection. The supply voltage should agree with the voltage on the label, and the supply capacity should be sufficient for the amperage on the label.

The supply should be fused at the next size equal to or higher than the amperage on the label. A table of the most common fuse ratings is also given in 8.0 of this manual. Where a supply cable is present there are internal supply fuses; customer fusing is preferred but not essential.

Furnace with supply cable: either wire directly to an isolator or fit with a line plug.

Furnace without supply cable: a permanent connection to a fused and isolated supply should be made to the internal terminals after temporary removal of the furnace back panel.

Connection by line plug: the plug should be within reach of the operator, and should be quickly removable.

Connection to isolating switch: this should operate on both conductors (single phase) or on all live conductors (three phase), and should be within reach of the operator.

The supply MUST incorporate an earth (ground).

ELECTRICAL CONNECTION DETAILS			<i>supply type</i>	
Supply	Terminal label	Cable colour	<i>Live-Neutral</i>	<i>Reversible or Live-Live</i>
1-phase	L	Brown	To live	to either power conductor
	N	Blue	To neutral	to the other power conductor
	PE	Green/Yellow	To earth (ground)	to earth (ground)
supply	Terminal label	Cable colour		
2- or 3-phase	L1	Black	to phase 1	
	L2	Black	to phase 2	
	L3	Black	to phase 3 <i>except 2-phase</i>	
	N	Light Blue	to neutral <i>except delta</i>	
	PE	Green/Yellow	to earth (ground)	

2.4 “Universal Wiring”

Year 2000: 23 litre 3-phase models only

Year 2001: 23 litre 1-phase and 3-phase

The 23 litre models (CWF, BWF, RWF --/23) can be easily rewired between 1-phase and 3-phase supplies. This applies to 3-phase+N and 3-phase delta in the ranges 380/220V–415/240V and 208-240V, but does not apply to 3-phase star without neutral (e.g 380V).

To alter the configuration, remove the back panel and alter the wiring connections between the supply terminal block and the EMC filters, using the appropriate diagram from section 7.4.

Models made for single phase only (e.g. before year 2001) are not affected and cannot be converted to 3-phase.

If in doubt, please consult Carbolite.

3.0 OPERATION

The instructions for operating the temperature controller are given in a separate manual.

If the furnace is fitted with a time switch, see also the supplementary manual MS03.

If cascade control is fitted, see the supplementary manual MS07.

3.1 Operating Cycle

The furnace is fitted with a combined Supply light and Instrument switch. The light is on whenever the furnace is connected to the supply. The switch cuts off power to the control circuit.

Connect the furnace to the electrical supply. The Supply light should glow.

Operate the instrument switch to activate the temperature controller; the **O** position is *off*, the **I** position *on*. The controller becomes illuminated and goes through a short test cycle.

Close the furnace door and adjust the temperature controller – see the controller manual.

Overtemperature option only. If the overtemperature controller has not yet been set as required, set it and activate it according to the instructions in the appropriate manual.

Unless a time switch is fitted and is off, the furnace starts to heat up. The Heat light(s) glow steadily at first and then flash as the furnace approaches the desired temperature or a program setpoint.

Overtemperature option only. If the overtemperature trip operates then an indicator in the overtemperature controller flashes, and the heating elements are isolated. Find and correct the cause before resetting the overtemperature controller according to the instructions supplied.

To switch the furnace off, set the Instrument switch to **O**. If the furnace is to be left off, isolate it the electrical supply.

3.2 General Operating Notes

Heating element life is shortened by use at temperatures close to maximum. Do not leave the furnace at high temperature when not required. The maximum temperature is shown on the furnace rating label and on the back page of this manual.

When heating large objects, in particular poor conductors, avoid shielding the thermocouple from the heating elements. The thermocouple is intended to sense the temperature near the heating element, but if a large object is placed in the chamber it may record the average temperature of the object and the elements, which can lead to overheating of the elements. Allow large objects to gain heat at a lower temperature and then reset the controller to a temperature close to the desired maximum.

When heating materials which produce smoke or fumes, the chimney must be correctly fitted and unobstructed. Otherwise, soot accumulates in the chamber and could possibly cause an electrical breakdown of the heating element.

If the furnace is used to heat materials which emit smoke or fumes, regularly heat it up to maximum temperature for one hour without load to burn away the soot.

Materials such as case hardening compounds and other reactive salts may penetrate the furnace chamber lining and attack the wire elements, causing premature failure. Use of a hearth tile may be advisable: please consult our technical department.

3.3 Use of Probes

Any metal object used to probe into the furnace chamber while the furnace is connected to the supply must be earthed (grounded). This applies in particular to metal sheathed thermocouples, where the sheaths must be earthed. The refractory material of the chamber lining becomes partly conducting at high temperatures, and the electric potential inside the chamber can be at any value between zero and the supply voltage. Unearthed probes can cause serious electric shock.



3.4 Atmospheres

When an optional gas inlet is fitted there is a label near the inlet saying "INERT GAS ONLY". In practice *inert* or *oxidising* gases may be used, but *not combustible or toxic gases*. Chamber furnaces are not gas tight, so it should be understood that gas usage may be high, and that the chamber is likely always to contain some air. Residual oxygen levels of 1% are to be expected.

If a metal retort is supplied with this furnace, please see the supplementary manual MS05.

3.5 Operator Safety

The furnace incorporates a safety switch which interrupts the heating element circuit when the door is opened. This prevents the user touching a live heating element, but also prevents the furnace from heating up if the door is left open. The operation of this switch should be checked periodically – see section 4.1.2.

Avoid burns: furnace surfaces can be hot. Before you remove a hot object from the furnace make sure you have a safe place to put it down.

3.6 Power Adjustment

The furnace control system incorporates electronic power limiting. Depending on the model and the destination country the power limit may be set to 100% or a lower figure. Where appropriate the power limit parameter $\square PH$ is accessible to the operator, but it should not generally be altered.

See section 8.0 for details of power limit settings. DO NOT adjust the power to a level higher than the design level stated: this may cause a fuse to blow, and could damage the heating elements.

The power limit may be set to a lower limit if the furnace is to be used at a low temperature only: this may give better control stability. It may be set to zero to permit demonstration of the controls without the heating elements taking power; to resume heating reset it to its standard value.

4.0 MAINTENANCE

4.1 General Maintenance

Preventive rather than reactive maintenance is to be preferred. The type and frequency depends on furnace use: the following are recommended.

4.1.1 Cleaning

Soot deposits may form inside the furnace, depending on the process. At appropriate intervals remove these by heating as indicated in section 3.2.

The furnace outer surface may be cleaned with a damp cloth. Do not allow water to enter the interior of the case or chamber. Do not clean with organic solvents.

4.1.2 Safety Switch

The door switch operation mentioned in 3.5 should be checked periodically to ensure that heating elements are isolated when the door is opened. In normal conditions the safety arrangement should outlast the furnace, but it could be affected by rough handling, a corrosive environment or work materials, or exceptional frequency of use.

A qualified electrician should check that the supply to the heating elements is cut, with and without power being on, when the door is open partially and fully; it is important that isolation is not just marginally achieved. The check is best made on the element terminals after removal of the furnace back: probing the element surface inside the furnace could be inconclusive because of surface oxidation. Note that all live supply wires of a 3-phase supply, and both live and neutral of a 1-phase supply, should be isolated when the door is opened.

4.2 Calibration

After prolonged use the controller and/or thermocouple could require recalibration. This would be important for processes which require accurate temperature readings or which use the furnace close to its maximum temperature. A quick check using an independent thermocouple and temperature indicator should be made from time to time to determine whether full calibration is required. Carbolite can supply these items.

Depending on the controller, the controller manual may contain calibration instructions.

4.3 After Sales Service

Carbolite's service division (Thermal Engineering Services) has a team of Service Engineers capable of repair, calibration and preventive maintenance of furnace and oven products at our customers' premises throughout the world. We also sell spares by mail order. A telephone call or fax often enables a fault to be diagnosed and the necessary spare part despatched.

Each furnace has its own record card at Carbolite. In all correspondence please quote the serial number, model type and voltage given on the rating label of the furnace. The serial number and model type are also given on the front of this booklet when supplied with a furnace.

To contact Thermal Engineering Services or Carbolite see the back page of this manual.

4.4 Recommended Spares Kits

Carbolite can supply individual spares, or a kit of the items most likely to be required. Ordering a kit in advance can save time in the event of a breakdown. Each kit comprises one thermocouple, one sheath, one solid state relay, one door insulation piece, one element or set of elements, and one hearth tile. For the RWF models, the element is supplied in its metal housing or insulation box; for the CWF & BWF models, the two side elements are supplied. Individual spares are also available.

When ordering spares please quote the model details as requested above.

5.0 REPAIRS & REPLACEMENTS

5.1 Safety Warning – Disconnection from Supply

Always ensure that the furnace is disconnected from the supply before repair work is carried out.

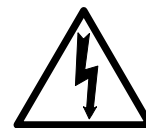

5.2 Safety Warning - Refractory Fibrous Insulation

This furnace contains refractory fibres in its thermal insulation. These materials may be in the form of fibre blanket or felt, vacuum formed board or shapes, mineral wool slab or loose fill fibre.



Normal use of the furnace does not result in any significant level of airborne dust from these materials, but much higher levels may be encountered during maintenance or repair.

Whilst there is no evidence of any long term health hazards, we strongly recommend that safety precautions are taken whenever the materials are handled.

Exposure to dust from fibre which has been used at high temperatures may cause respiratory disease.

When handling fibre always use an approved mask, eye protection, gloves and long sleeved clothing.

Avoid breaking up waste material. Dispose of waste fibre in sealed containers.

After handling rinse exposed skin with water before washing gently with soap (not detergent). Wash work clothing separately.

Before commencing any major repairs we recommend reference to the European Ceramic Fibre Industry Association Bulletin No. 11 and the UK Health and Safety Executive Guidance Note EH46.

We can provide further information on request. Alternatively our service division can quote for any repairs to be carried out at your premises or ours.

5.3 Temperature Controller Replacement

201. This controller is fitted to the back of the control panel; in many models this can be separated from the base by removal of two screws.



Before handling the controller: **wear an anti-static wrist strap** or otherwise avoid any possibility of damage to the unit by static electricity.

Refer to the detailed instructions supplied with the replacement controller.

2132, 2416, 2408 etc. Ease apart the two lugs at the side; grip the instrument and withdraw it from its sleeve; push in the replacement.

5.4 Solid-state Relay Replacement

Disconnect the furnace from the supply and remove the furnace back panel.

Make a note how the wires are connected to the solid state relay, and disconnect them.

Remove the solid state relay from the base panel or aluminium plate.

Replace and reconnect the solid state relay ensuring that the heat-conducting thermal pad is sandwiched between the relay and the base panel or aluminium plate. Alternatively a thin layer of white, heat-conducting silicon paste may be applied between the new relay and the plate.

The new solid state relay contains a built-in MOV which protects it from short periods of excess voltage. If the old relay had a separate disc-shaped "MOV" connected between the high voltage terminals of the old relay, discard the old MOV.

Replace the removed panel.

5.5 Thermocouple Replacement

Disconnect the furnace from the supply, and remove the furnace back panel.

Make a note of the thermocouple connections. The negative leg of the thermocouple is marked blue. Compensating cable colour codings are:

<i>Negative</i>	<i>positive (type K)</i>	<i>positive (type R)</i>
White	green	orange

Disconnect the thermocouple from its terminal block.

Bend the metal tag to release the thermocouple sheath, withdraw the sheath, and shake out any fragments of thermocouple.

Re-assemble with a new thermocouple observing the colour coding, ensuring that the thermocouple is not twisted as it is being inserted and that the metal tag is bent back to grip the sheath.

5.6 Panel Element Replacement (CWF & BWF)



See section 5.2 - wearing a face mask is recommended.

The chambers have two side-mounted refractory panels in which coiled heating elements are inserted, and one unheated hearth slab.

Disconnect the furnace from the supply and remove the furnace back panel.

Make a written plan showing ALL the element and thermocouple connections. It is important to make this plan for each individual furnace.

Disconnect all the element wire tails and thermocouple cables from their terminal blocks. Straighten all the element tails. Note that these become brittle with use.

Unscrew the screws fixing the metal back piece from the inner chamber and withdraw this part backwards complete with thermocouple(s) and sheath(s).

Withdraw the back insulation piece. Handle with care. Observe the warning on handling of ceramic fibrous insulation - section 5.2.

Withdraw the old element(s), and insert the new. Note that in the 23 litre models the ceramic element carriers are in two parts: handle with care.

Replace the back insulation piece and metal piece together with the thermocouple(s) and sheath(s).

As necessary, shorten the element tails by clipping to length. Remake all the thermocouple and element connections according to the individual plan.

Refit the back panel and run the furnace for 30 minutes at 800°C without interruption to ensure complete burn-off of any organic binders. Some smoke may be observed during this process, which should be carried out in a well ventilated area.

Check that the furnace is controlling properly to rule out the possibility that previous element failed because of a fault elsewhere in the control circuit.

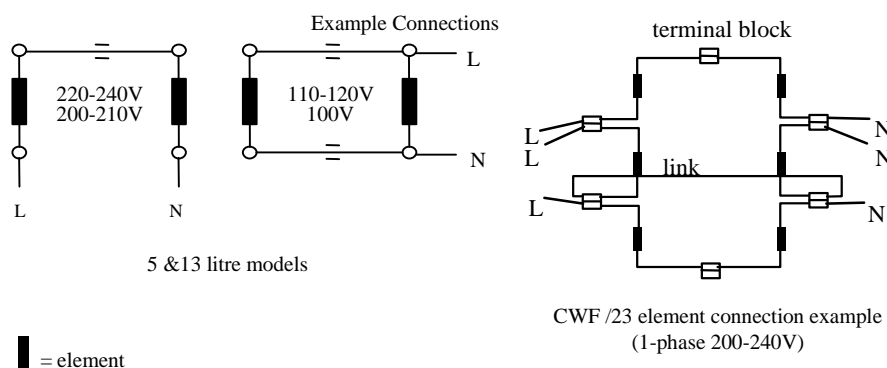

5.7 RWF Element Replacement



See section 5.2- wearing a face mask is recommended.

The special RWF heating elements form the chamber sides, base and roof in a single module. The element is fragile, so spare elements are supplied complete in an insulation box to avoid damage.

Disconnect the furnace, remove the back panel, make a plan and disconnect the lead, as for CWF, section 5.6 above.

Remove the thermocouple(s) and support tube(s).

Using a socket spanner undo the four bolts that fasten the insulation box. These are located under the insulation box in the two cross supports.

Remove the insulation box by carefully sliding it out through the back of the furnace case.

Carefully slide in the new insulation box, and fasten the four bolts. DO NOT support the element by putting your hand inside the chamber - the element is fragile.

As necessary, shorten the element tails (etc., as for CWF, section 5.6).

Remember to make a plan of the connections.

5.8 Door Plug Replacement

Lift the furnace door to the open position and remove the door cover from the plug carrier assembly.

Remove the old door plug by sliding it upwards out of its carrier.

Slide the new plug into the carrier assembly making sure that the plug is the correct way up.

Refit the door cover.

When first heating the furnace after a replacement, ensure that the ventilation is good: emission of some fumes may be expected.

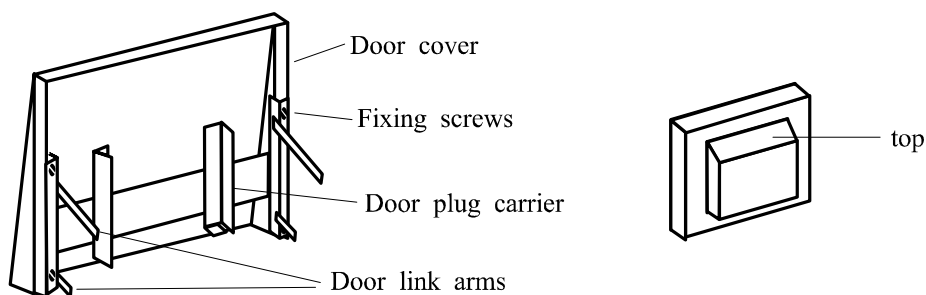

Door

(seen from the back)

Door Plug

5.9 Fuse Replacement

Fuses are marked on the circuit diagram (section 7.0) with type codes, e.g. F1, F2. A list of the correct fuses is given in section 8.0. *Depending on model and voltage, the different fuse types may or may not be fitted.*

If any fuse has failed, it is advisable for an electrician to check the internal circuits.

Replace any failed fuses with the correct type. For safety reasons do not fit larger capacity fuses without first consulting Carbolite.

The fuses are near the cable entry point, and access is by removal of the back panel.

6.0 FAULT ANALYSIS

A. Furnace Does Not Heat Up

- | | | | |
|----|-------------------------------------|--|--|
| 1. | The HEAT light is ON | → The heating element has failed | → Check also that the SSR is working correctly |
| 2. | The HEAT light is OFF | The controller shows a very high temperature or a code such as S.br | → The thermocouple has broken or has a wiring fault |
| | | The controller shows a low temperature | → The door switch(es) (if fitted) may be faulty or need adjustment |
| | | | → The contactor (if fitted) may be faulty |
| | | | → The SSR could be failing to switch on due to internal failure, faulty logic wiring from the controller, or faulty controller |
| | | There are no lights glowing on the controller | → The SUPPLY light is ON → The controller may be faulty or not receiving a supply due to a faulty switch or a wiring fault |
| | | | → The SUPPLY light is OFF → Check the supply fuses and any fuses in the furnace control compartment |

B. Furnace Overheats

- | | | | |
|----|---|---|--|
| 1. | The HEAT light goes OFF with the instrument switch | → The controller shows a very high temperature | → The controller is faulty |
| | | → The controller shows a low temperature | → The thermocouple may have been shorted out or may have been moved out of the heating chamber |
| | | | → The thermocouple may be mounted the wrong way round |
| | | | → The controller may be faulty |
| 2. | The HEAT light does not go off with the instrument switch | → The SSR has failed "ON" | → Check for an accidental wiring fault which could have overloaded the SSR |

7.0 CIRCUIT DIAGRAMS

EMC Filters (if fitted): dependent on the model there may be one filter, or more than one fitted in parallel. The circuit diagram examples do not show multiple filter arrangements.

7.1 Single Phase

NOTE – year 2001 onwards: single phase model --/23 replaced by Universal model – see 7.4.

NOTE – models before mid-2002: in some models two door switches were fitted directly in the element circuit, instead of a single switch and contactor.

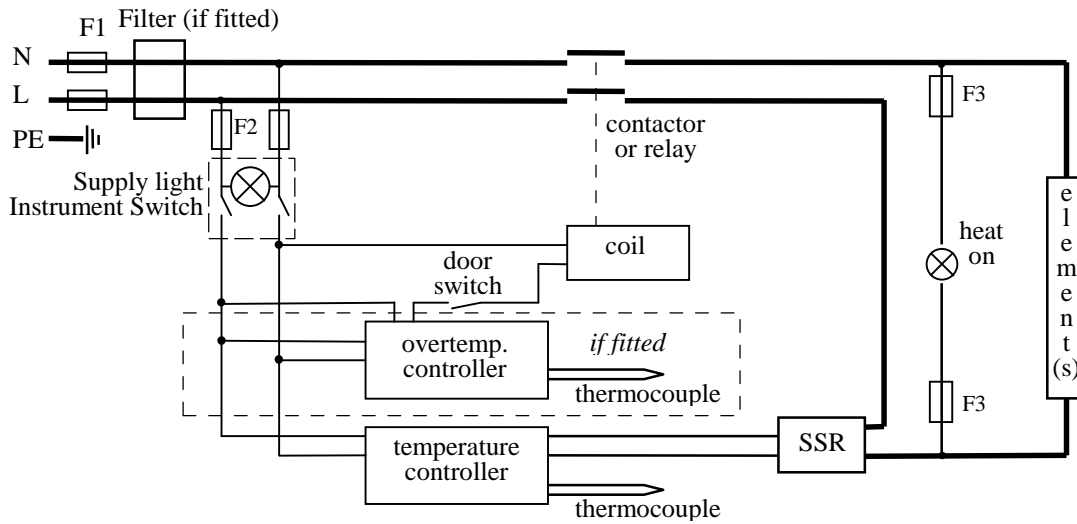

7.2 2-phase with neutral

Please enquire if a diagram is required.

7.3 Higher Voltages (e.g. 254V; 440V, 480V 3-phase)

The diagram above (7.5) normally applies, with neutral (if present) not being used.

For single phase models of 254V or above, diagram 7.1 or 7.4 applies except that a control circuit transformer is included as in diagram 7.5.

7.4 3-phase “universal” wiring

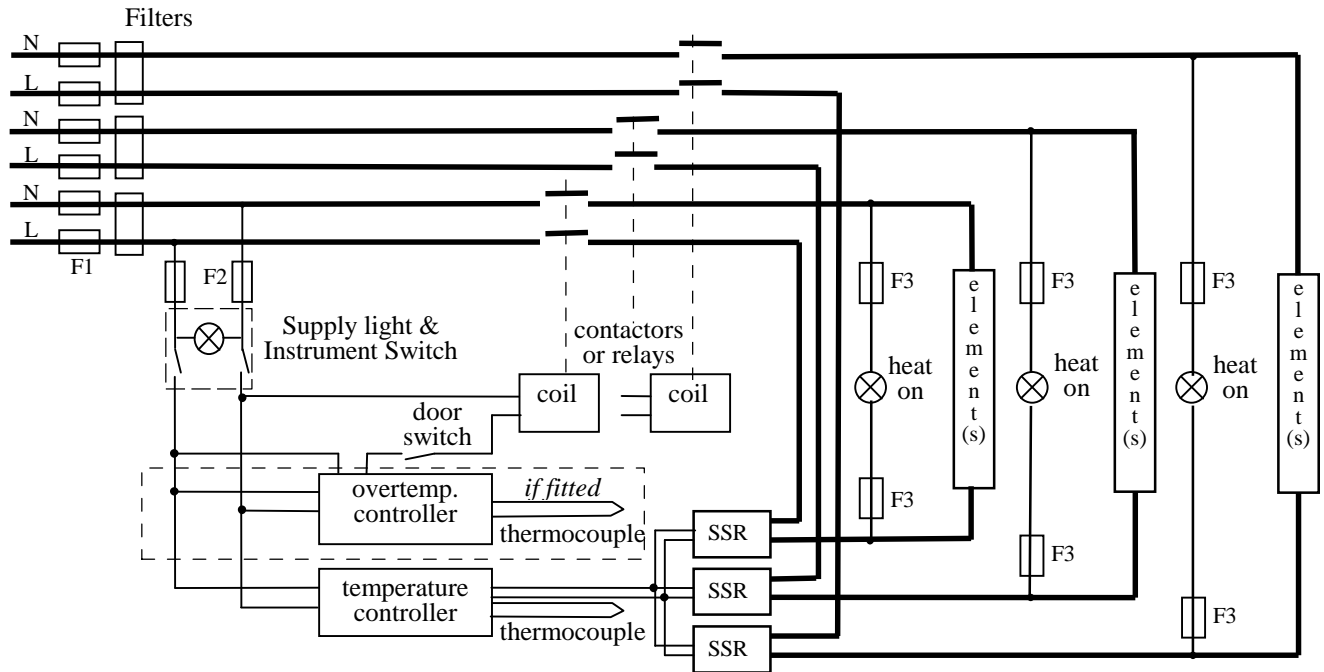

Fuses F1 are always present in this wiring design.

Fuses F2 could be absent in some circumstances, if the circuit does not exceed 10A.

Fuses F3 are present if the circuit exceeds 25A, but otherwise are usually absent.

3-phase + neutral

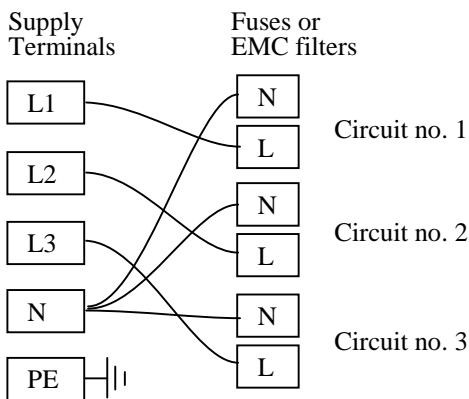

3-phase delta

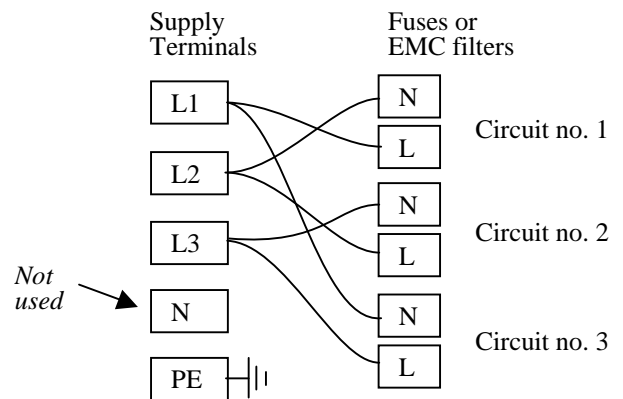

A model made to this diagram can be converted by the customer between the following supply voltages:

between 3-phase + neutral in the range 380/220V – 415/240V

and 3-phase delta in the range 220V – 240V

and single phase in the range 220V – 240V

208V model: convertible from 208V delta to 208V 1-phase

1-phase

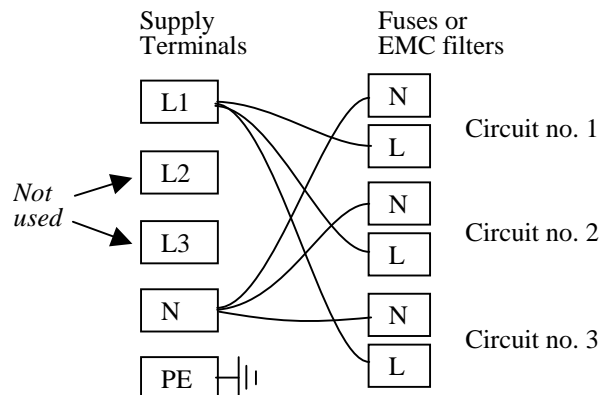

7.5 3-phase without neutral (star – e.g. 380 to 415V)

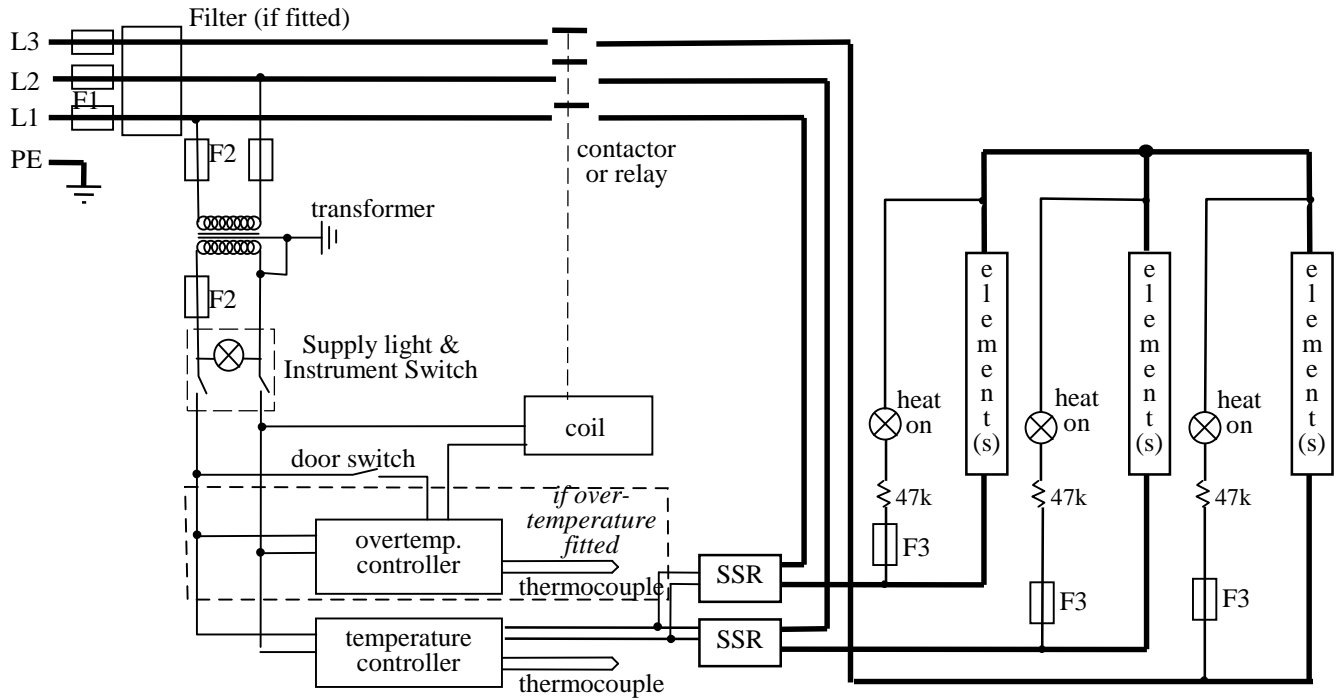

In this configuration the fuses F2 on the supply side of the transformer may be GEC Safeclip, not 32 x 6mm glass as stated in section 8.0.

8.0 FUSES & POWER SETTINGS

F1-F3: Refer to the circuit diagrams.

<i>F1</i>	Internal supply fuses	Fitted if supply cable fitted. Fitted on board to some types of EMC filter.	on-board and up to 16 Amps: 32mm x 6mm type F other: GEC Safeclip
<i>F2</i>	Auxiliary circuit fuses	Fitted on board to some types of EMC filter. May be omitted up to 25Amp/phase supply rating.	2 Amps glass type F On board: 20mm x 5mm Other: 32mm x 6mm
<i>F3</i>	Heat Light fuses	May be omitted up to 25 Amp/phase supply rating.	2 Amps glass type F 32mm x 6mm
	Customer fuses	Required if no supply cable fitted. Recommended if cable fitted.	See rating label for amperage; see table below for fuse rating.

Standard Models

BWF range - same as CWF

Model	Phases	Volts	Supply Fuse Rating	110 220 380	115 230 400	120 240 415	254 440
CWF -/5	1-phase	220-240	10A	100	100	100	89
CWF -/5	1-phase	110-120	20A	100	100	100	89
CWF -/13	1-phase	220-240	12.5A	100	100	100	89
CWF -/13	1-phase	110 / 120	25A / 30-32A	100	100	100	89
CWF -/23	1-phase	220-240	30-32A	100	100	100	89
CWF -/23	3-phase+N	380/220 - 415/240	12.5A/ph	100	100	94	83
CWF -/23	3-ph delta	220-240	20A	100	100	94	83
RWF -/5	1-phase	220-240	12.5A	100	100	100	89
RWF -/5	1-phase	110-120	25A	100	100	100	89
RWF -/13	1-phase	220-240	25A	100	100	100	89
RWF -/13	1-phase	110-120	50A	100	100	100	89
RWF -/13	2-phase+N	380/220 - 415/240	12.5A/ph	100	100	100	89
RWF -/23	1-phase	220-240	40A	100	100	100	89
RWF -/23	3-phase+N	380/220 - 415/240	12.5A/ph	100	100	100	89
RWF -/23	3-ph delta	220-240	25A/ph	100	100	100	89

USA models with 208V elements *; also 100V & 200V models

Model	Phases	Volts	Supply Fuse Rating	100 200	208	220	230	240
CWF -/5	1-phase	208-240	12.5A	100	92	83	75	69
CWF -/13	1-phase	208-240	16A	100	98	87	80	74
CWF -/23	1-phase	208	40A	100	100			
CWF -/23	3-ph delta	208	25A/ph	100	100			
RWF -/5	1-phase	208-240	16A	100	100	89	82	75
RWF -/13	1-phase	208-240	25A	100	100	89	82	75
RWF -/23	1-phase	208	50A	100	100			
RWF -/23	3-ph delta	208	25A/ph	100	100			

* Up to 13 litre: for USA the 208V models are supplied, and power limit set accordingly. Amps ratings are as for 208V, regardless of actual voltage.

9.0 SPECIFICATIONS

Carbolite reserves the right to change specifications without notice.

9.1 Models Covered by this Manual

MODEL	Max. Temp. (°C)	Max. Power (kW)	Chamber Size (mm)			Approx. Capacity (l)	Net Weight (kg)
			H	W	D		
<i>Chamber furnaces heated by resistance wire inserted in refractory formers.</i>							
CWF 11/5	1100°C	2.4	135	140	250	5	30
CWF 11/13	1100°C	3.1	200	200	325	13	47
CWF 11/23	1100°C	7.5	235	245	400	23	68
CWF 12/5	1200°C	2.4	135	140	250	5	30
CWF 12/13	1200°C	3.1	200	200	325	13	47
CWF 12/23	1200°C	7.5	235	245	400	23	68
CWF 13/5	1300°C	2.4	135	140	250	5	30
CWF 13/13	1300°C	3.1	200	200	325	13	47
CWF 13/23	1300°C	7.5	235	245	400	23	68
<i>Burn-off versions of the above.</i>							
BWF 11/13	1100°C	3.1	200	200	325	13	47
BWF 12/13	1200°C	3.1	200	200	325	13	47
<i>Chamber furnaces heated by resistance wire embedded in low thermal mass insulation.</i>							
RWF 11/5	1200°C	2.75	130	160	250	5	28
RWF 11/13	1200°C	5.0	195	210	325	13	45
RWF 11/23	1200°C	9.1	220	260	400	23	65
RWF 12/5	1200°C	2.75	130	160	250	5	28
RWF 12/13	1200°C	5.0	195	210	325	13	45
RWF 12/23	1200°C	9.1	220	260	400	23	65

9.2 Environment

The furnaces contain electrical parts and should be stored and used in indoor conditions as follows:

temperature: 5°C - 40°C
 relative humidity: maximum 80% up to 31°C decreasing linearly to 50% at 40°C

The products covered in this manual are only a small part of the wide range of ovens, chamber furnaces and tube furnaces manufactured by Carbolite for laboratory and industrial use. For further details of our standard or custom built products please contact us at the address below, or ask your nearest stockist.

For preventive maintenance, repair and calibration of all Furnace and Oven products, please contact:

Thermal Engineering Services

Telephone: UK: 0845 3308035 Int: +44 1433 623335
 Fax: UK: 0845 3308036 Int: +44 1433 623336
 Email: service@thermalservice.com

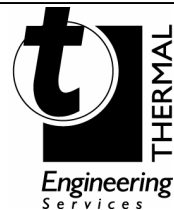

MF02-3.15

30/3/04

CWF

Carbolite, Parsons Lane, Hope, Hope Valley, S33 6RB, England.

Telephone: (01433) 620011

Int: +44 1433 620011

Facsimile: (01433) 621198

Int: +44 1433 621198

E-mail: info@carbolite.com