



Installation, Operation & Maintenance Instructions

Models SNF and VMF/ASTM

This manual is for the guidance of operators of the above Carbolite products and should be read before the furnace is connected to the electricity supply.

CONTENTS

Section		page
1.0	Symbols & Warnings	2
2.0	Installation	3
3.0	Operation	4
4.0	Maintenance	5
5.0	Repairs & Replacements	6
6.0	Fault Analysis	8
7.0	Circuit Diagrams	9
8.0	Fuses & Power Settings	10
9.0	Specifications	12

Manuals are supplied separately for the furnace controller (and overtemperature controller when fitted).

Please read the controller manuals before operating the furnace.



1.0 SYMBOLS & WARNINGS

1.1 Switches and Lights



Supply Light: when the furnace is connected to the electrical supply the light in the adjacent switch glows



Heat Light: the adjacent light glows or flashes to indicate that power is being supplied to the elements

1.2 Warning Symbols

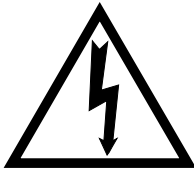

DANGER of electrical shock— read any warning printed by this symbol.



DANGER – hot surface. Read any warning printed by this symbol.
WARNING: all surfaces of a furnace may be hot.



DANGER – read any warning printed by this symbol.

2.0 INSTALLATION

2.1 Unpacking & Handling

When unpacking or handling the furnace always lift it by its case. Do not apply lifting force to any protruding part..

Remove any packing material from the furnace lid or chamber before use.

2.2 Siting & Setting Up

Place the furnace in a well ventilated room, away from other sources of heat, and on a surface which is resistant to accidental spillage of hot materials. Do not mount the furnace on an inflammable surface.

Ensure that there is free space around the furnace. Do not obstruct any of the vents in the case: they are needed to keep the controls and the case exterior cool.

Ensure that the furnace is placed in such a way that it can be quickly switched off or disconnected from the electrical supply - see below.

The furnace is supplied with a crucible holder (a small component made of wire). Ensure that this is present.

2.3 Electrical Connections

Connection by a qualified electrician is recommended.

The furnace requires a single-phase A.C. supply with earth (ground). The supply may be Live to Neutral non-reversible, Live to Neutral with reversible plug, or Live to Live.

Check the furnace rating label before connection. The supply voltage should agree with the voltage on the label, and the supply capacity should be sufficient for the amperage on the label.

The supply should be fused at the next size equal to or higher than the amperage on the label. A table of the most common fuse ratings is also given in section 9 of this manual. Where a supply cable is present there are internal supply fuses; customer fusing is preferred but not essential.

The furnace is fitted with a supply cable: either wire directly to an isolator or fit with a line plug. A connection to an isolating switch should operate on both and should be within reach of the operator. A line plug should be quickly removable, and should be within reach of the operator.

The supply MUST incorporate an earth (ground).

CONNECTION DETAILS			<i>supply type</i>	
Supply	Terminal label	Cable colour	<i>Live-Neutral</i>	<i>Reversible or Live-Live</i>
<i>1-phase</i>	L	Brown	To live	to either power conductor
	N	Blue	To neutral	to the other power conductor
	PE	Green/Yellow	To earth (ground)	to earth (ground)

3.0 OPERATION

The instructions for operating the temperature controller are given in a separate manual.

3.1 Operating Cycle

The furnace is fitted with a combined Supply light and Instrument switch. The light is on whenever the furnace is connected to the supply. The switch cuts off power to the control circuit.

Switch on the electrical supply. The Supply light should glow.

Operate the instrument switch, located on the front panel, to activate the temperature controller; the **O** position is *off*, the **I** position *on*. The controller becomes illuminated and undergoes a short test cycle.

Adjust the temperature controller – see separate manual supplied.

Overtemperature option only. If the overtemperature controller has not yet been set as required, set it and activate it according to the instructions in the separate manual supplied.

The furnace starts to heat up according to the controller set point or program. The Heat light glows steadily at first and then flashes as the furnace approaches the desired temperature or a program setpoint.

Overtemperature option only. If the overtemperature trip operates then an indicator in the overtemperature controller flashes, and the heating elements are isolated. Find and correct the cause before resetting the overtemperature controller according the instructions supplied.

To switch the furnace off, set the Instrument switch to **O**. If the furnace is to be left off, isolate it from the electrical supply.

3.2 Notes on the Test

The furnace is intended for use with tests in accordance with BS1016: Part107.1:1991 and ISO501:1981.

Before commencing the test, the furnace chamber lid should be opened and the temperature allowed to stabilise for no longer than 2 minutes. The test should be conducted with the furnace lid open. When the test is completed, close the lid to conserve energy and prolong element life.

3.3 Operator Safety

Ceramic materials used in furnace insulation can become conducting at high temperatures; there is therefore a potential danger to the operator, as this furnace is designed to be used with the chamber lid open.

To guard against this danger, the furnace is fitted with a 30mA earth leakage (residual current) circuit breaker mounted in the back of the case. This trips out in the event of accidental contact with the heating element or current leakage through the insulation.

The device may be reset after tripping out. From time to time, test it using the integral test button.

4.0 MAINTENANCE

4.1 General Maintenance

No routine maintenance is required other than the occasional replacement of consumable items.

The furnace outer surface may be cleaned with a damp cloth. Do not allow water to enter the interior of the case or chamber. Do not clean with organic solvents.

4.2 Calibration

After prolonged use the controller and/or thermocouple could require recalibration. This would be important for processes which require accurate temperature readings or which use the furnace close to its maximum temperature. A quick check using an independent thermocouple and temperature indicator should be made from time to time to determine whether full calibration is required.

Depending on the controller, the controller manual may contain calibration instructions.

4.3 After Sales Service

Carbolite's service division (Thermal Engineering Services) has a team of Service Engineers capable of repair, calibration and preventive maintenance of furnace and oven products at our customers' premises throughout the world. We also sell spares by mail order. A telephone call or fax often enables a fault to be diagnosed and the necessary spare part despatched.

Each furnace has its own record card at Carbolite. In all correspondence please quote the serial number, model type and voltage given on the rating label of the furnace. The serial number and model type are also given on the front of this booklet when supplied with a furnace.

To contact Thermal Engineering Services or Carbolite see the back page of this manual.

4.4 Recommended Spares Kits

Carbolite can supply individual spares, or a kit of the items most likely to be required. Ordering a kit in advance can save time in the event of a breakdown.

Each kit comprises one thermocouple, one sheath, one solid state relay, one element, and one lid insulation piece.

When ordering spares please quote the model details as requested above.

Crucibles with lids, and spare crucible holders, can also be supplied.

4.5 Power Adjustment

The furnace control system incorporates electronic power limiting, but in these models the power limit is set to 100% and the power limit parameter DPH may be inaccessible to the operator.

Occasionally the power limit is set to zero to permit demonstration of the controls without the heating elements taking power. In this case the power limit is accessible to the operator and may safely be reset to its standard value, usually 100.

Check section 8.2 for details of power limit settings.

5.0 REPAIRS & REPLACEMENTS

5.1 Safety Warning – Disconnection from Supply

Always ensure that the furnace is disconnected from the supply before repair work is carried out.

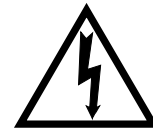

5.2 Safety Warning - Refractory Fibrous Insulation

This furnace contains refractory fibres in its thermal insulation. These materials may be in the form of fibre blanket or felt, vacuum formed board or shapes, mineral wool slab or loose fill fibre.



Normal use of the furnace does not result in any significant level of airborne dust from these materials, but much higher levels may be encountered during maintenance or repair.

Whilst there is no evidence of any long term health hazards, we strongly recommend that safety precautions are taken whenever the materials are handled.

Exposure to dust from fibre which has been used at high temperatures may cause respiratory disease.

When handling fibre always use an approved mask, eye protection, gloves and long sleeved clothing.

Avoid breaking up waste material. Dispose of waste fibre in sealed containers.

After handling rinse exposed skin with water before washing gently with soap (not detergent). Wash work clothing separately.

Before commencing any major repairs we recommend reference to the European Ceramic Fibre Industry Association Bulletin No. 11 and the UK Health and Safety Executive Guidance Note EH46.

We can provide further information on request. Alternatively our service division can quote for any repairs to be carried out at your premises or ours.

5.3 Panel Removal

Except for temperature controller replacement, access to components is by removal of the top panel. Remove 10 self-tapping screws. Carefully save the 10 spacers (between the furnace case and the top panel). Lift off the top panel; ensure there is somewhere to place it without pulling on the wire connections.

5.4 Temperature Controller Replacement

200 & 201. These controllers are fitted to the back of the control panel, which can be separated from the base by removal of two screws.



Before handling the controller: **wear an anti-static wrist strap** or otherwise avoid any possibility of damage to the unit by static electricity.

Make a note of all the wiring connections to the controller. Disconnect the controller, fit the new one, reconnect all the wires, and reassemble the furnace.

2132, 208P, 216P etc. Ease apart the two lugs at the side; grip the instrument and withdraw it from its sleeve; push in the replacement.

5.5 Solid-state Relay Replacement

Remove the top panel as above. The solid state relay is mounted on an aluminium heat sink or on the bottom of the furnace case. Make a note of how the wires are connected to the solid state relay, and disconnect them.

Replace and reconnect the solid state relay ensuring that the heat-conducting thermal pad is sandwiched between the relay and the base panel or aluminium plate. Alternatively a thin layer of white, heat-conducting silicon paste may be applied between the new relay and the plate.

The new solid state relay contains a built-in MOV which protects it from short periods of excess voltage. If the old relay had a separate disc-shaped "MOV" connected between the high voltage terminals of the old relay, discard the old MOV.

Replace the removed panel.

5.6 Thermocouple Replacement

Remove the top panel as above. The thermocouple goes vertically into the bottom of the heating chamber.

Make a note of the thermocouple connections. Compensating cable colour codings are:
negative - white; positive - green

Disconnect the thermocouple from its terminal block.

Fit the replacement thermocouple and reconnect, observing the colour coding, and refit the removed panel.

5.7 Element Replacement



See section 5.2 - wearing a face mask is recommended.

Remove the top panel as above.

The heating chamber is suspended from the top plate. Make a note of the wiring connections; identify and those to the heating element, and disconnect it.

Separate the inner chamber by removing 4 screws. The heating element with its surrounding insulation can then be lifted out of the chamber.

Replace the element with the new one, and reverse the disassembly procedure.

5.8 Fuse Replacement

Fuses are marked on the circuit diagram (section 7.0) with type codes, e.g. F1. A list of the correct fuses is given in section 8.1.

Remove the top panel as given in section 7. The fuses are on the bottom plate; they may be mounted on an EMC filter.

If any fuse has failed, it is advisable for an electrician to check the internal circuits.

Replace any failed fuses with items of the correct type. For safety reasons do not fit larger capacity fuses without first consulting Carbolite.

6.0 FAULT ANALYSIS

A. Furnace Does Not Heat Up

- | | | | | |
|--|---|--|---|--|
| 1. The SUPPLY light is OFF | → | No power from the supply | → | Check the fuses in the supply line |
| 2. The SUPPLY light is ON | → | The controller shows a very high temperature or a code such as S.br | → | The thermocouple has broken or has a wiring fault |
| | → | The controller shows a low temperature | → | The SSR could be failing to switch on due to internal failure, faulty logic wiring from the controller, or faulty controller |
| | → | There are no lights glowing on the controller | → | The controller may be faulty or not receiving a supply due to a faulty switch or a wiring fault |

B. Furnace Overheats

- | | | | | |
|--|---|---|---|--|
| 1. Furnace only heats up when the instrument switch is ON | → | The controller shows a very high temperature | → | The controller is faulty |
| | → | The controller shows a low temperature | → | The thermocouple may have been shorted out or may have been moved out of the furnace |
| | | | → | The thermocouple may be mounted the wrong way round |
| | | | → | The controller may be faulty |
| 2. Furnace heats up when the instrument switch is OFF | → | The SSR has failed "ON" | → | Check for an accidental wiring fault which could have overloaded the SSR |

7.0 CIRCUIT DIAGRAMS

7.1 SNF & VMF/ASTM

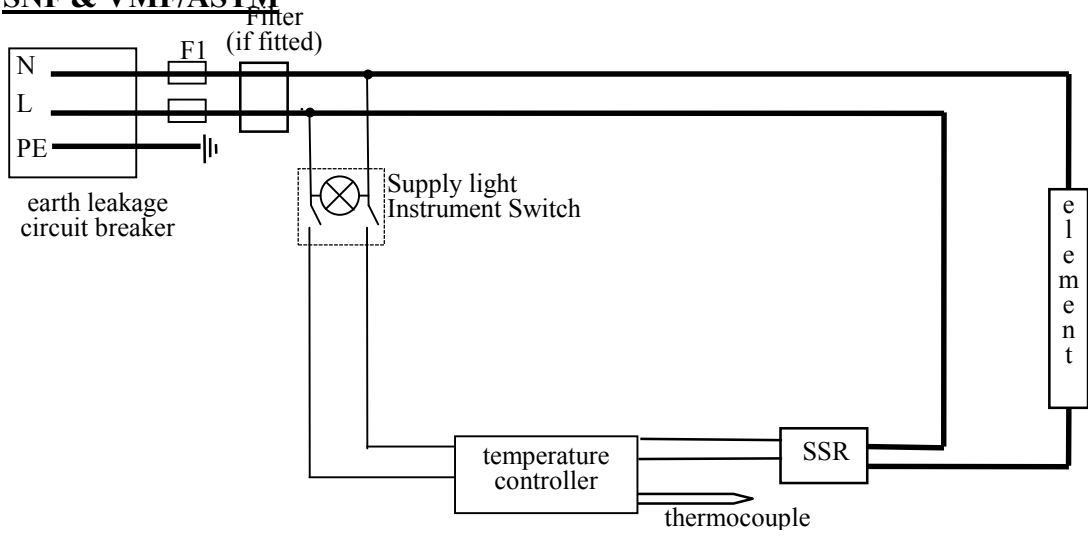

8.0 FUSES & POWER SETTINGS**8.1 Fuses**

Fuses are marked F1 on the diagram above. The fuse type is 32mm x 6mm glass type F (quick blow).

model	volts	phases	supply fuse rating
SNF	220-240V	1	5A
SNF	110-120V	1	7A
VMF/ASTM	220-240V	1	5A

8.2 Power Settings

For models made for 254 volts the power limit parameter $\square PH_i$ may be set to 89%.

For all other models in this manual the power limit parameter $\square PH_i$ is set to 100%.

9.0 SPECIFICATIONS

Carbolite reserves the right to change specifications without notice.

9.1 Models Covered by this Manual

MODEL	Max. Temp. (°C)	Max. Power (kW)	Chamber Size (mm)	Net Weight (kg)
<i>Swelling Number Furnace</i>				
SNF	900°C	1.0	70 dia x 80 deep	26
VMF/ASTM	1000°C	1.0	50 dia x 140 deep	

9.2 Environment

The furnaces contain electrical parts and should be stored and used in indoor conditions as follows:

- temperature: 5°C - 40°C - except incubators (*incubators cannot maintain a low temperature unless the ambient temperature is also low*)
- relative humidity: maximum 80% up to 31°C decreasing linearly to 50% at 40°C

The products covered in this manual are only a small part of the wide range of ovens, chamber furnaces and tube furnaces manufactured by Carbolite for laboratory and industrial use. For further details of our standard or custom built products please contact us at the address below, or ask your nearest stockist.

For preventive maintenance, repair and calibration of all Furnace and Oven products, please contact:

Thermal Engineering Services

Telephone: UK: 0845 3308035 Int: +44 1433 623335
Fax: UK: 0845 3308036 Int: +44 1433 623336
Email: service@thermalservice.com

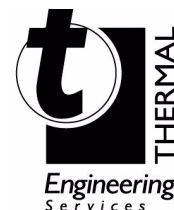

MF31-3.02

4/10/00

SNF

Carbolite, Parsons Lane, Hope, Hope Valley, S33 6RB, England.
Telephone: (01433) 620011
Int: +44 1433 620011
Facsimile: (01433) 621198
Int: +44 1433 621198
E-mail: info@carbolite.com